



Profit from the Eagle Advantage®

Phone: (800) 441-8440 • (302) 653-3000

FAX: (302) 653-2065

# Product Announcement

## Short Form Specifications

Eagle Group hand sink with eyewash, model \_\_\_\_\_. Fully enclosed base features tamper resistant hardware. All 300 series stainless steel construction. 1-1/2" drain. 16-gauge deck features a raised marine edge with a 6" x 1-3/4" backsplash. Downward facing paper towel holder for 10" x 11" multi-fold paper towels. Features electronic-eye hand wash faucet with battery backup, eyewash faucet with tepid water temperature thermostatic mixing valve, soap dispenser (wall-mount battery powered for HSAP-10-EYE, deck-mount for HSAP-14-EYE), tail-piece, and p-trap.

Item #:	_____
Model #:	_____
Project #:	_____
SIS #:	_____

EG8211 Rev. 12/24

### Design & Construction Features:

- Fully enclosed skirt with access panel.
- Compact, space saving design.
- All 300 series stainless steel construction.
- Electric-eye faucet with battery backup. Requires 120-volt electrical outlet.
- Eyewash faucet OSHA, ANSI Z358.1 compliant: OSHA 29 CFR 1910.151(c). Includes OSHA-compliant safety sign and emergency inspection tag.
- Thermostatic mixing valve to ensure correct water temperature is maintained: 60°-100°F (15.6 -37.8°C).
- Mounting brackets with hardware are pre-installed in base/apron for quick installation of mixing valve and faucet control, braided stainless hoses included.
- Multi-fold paper towel holder designed for Georgia-Pacific #20887.

### #HSAP-10-EYE

- Wall-mounted, battery-powered type LTX-12 liquid soap dispenser.
- Deck-mounted electronic-eye faucet.
- Splash-mounted eyewash.

### #HSAP-14-EYE

- Deck-mounted 16-oz. soap dispenser.
- Splash-mounted electronic-eye faucet.
- Splash-mounted eyewash.

For custom configuration or fabrication needs, contact our **SpecFAB® Division**.

Phone: (302) 653-3000. FAX: (302) 653-2065.

E-mail: quotes@eaglegrp.com

## Hand Sinks with Eyewash



#HSAP-10-EYE



#HSAP-14-EYE

*Introducing Eagle's newest addition: The Hand Sink with Built-In Eyewash! The unit's design saves space and fits easily into any work environment. Eyewash unit operates quickly by pulling swing arm down 90° over sink. Vandal-resistant ceramic valve limits wear and tear on moving parts, providing dependability and long lasting performance. Safe, steady water flow under varying water supply conditions, from 30 to 90 PSI, is assured by integral flow control in the sprayhead assembly. Eyewash spray heads contain an antimicrobial agent to protect the spray heads. Features protective hinged dust covers. Gentle spray bathes eyes and face. Ceramic discs provide a precise 20° activation and deactivation angle, minimizing excessive splashing when the unit is activated. Chrome-plated brass pipe and fittings.*



# Eagle Hand Sinks with Eyewash

#HSAP-10-EYE

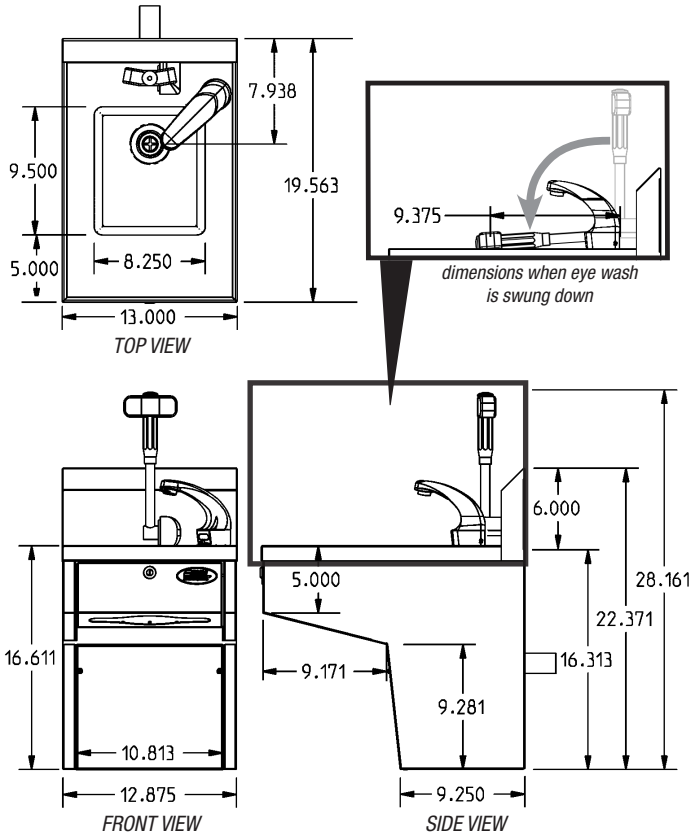

Components used in HSAP-10-EYE

Description	Manufacturer	Part #
Mixing valve	Guardian	G6020
Splash mount eyewash	Bradley	S19274HDR
Hand wash faucet	T&S	EC-3102

#HSAP-14-EYE

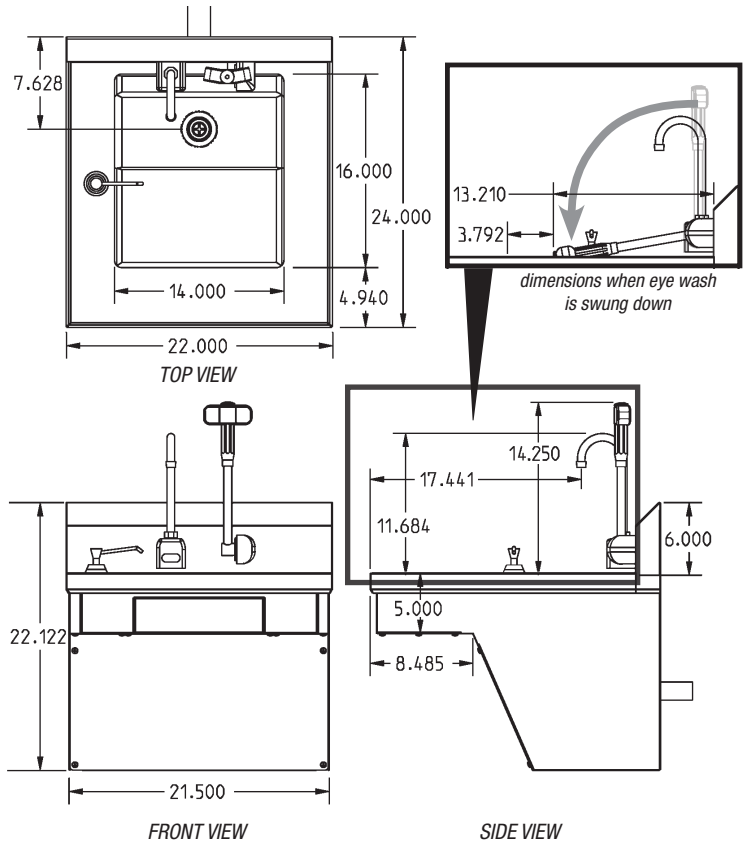

Components used in HSAP-14-EYE

Description	Manufacturer	Part #
Mixing valve	Guardian	G6020
Splash mount eyewash	Bradley	S19274HW
Hand wash faucet	Encore	K16-4000-MV

O.A. size (width x length x height)		bowl size (width x length x depth)		model #
in.	mm	in.	mm	
19 <sup>9</sup> / <sub>16</sub> " x 13" x 22 <sup>3</sup> / <sub>8</sub> "	497 x 330 x 568	9 <sup>1</sup> / <sub>2</sub> " x 8 <sup>1</sup> / <sub>4</sub> " x 5"	241 x 210 x 127	<b>HSAP-10-EYE</b>
24" x 22" x 22 <sup>1</sup> / <sub>8</sub> "	610 x 559 x 562	16" x 14" x 5"	406 x 356 x 127	<b>HSAP-14-EYE</b>