



Profit from the Eagle Advantage®

# Specification Sheet

## Short Form Specifications

Eagle Group hand sink with eyewash, model \_\_\_\_\_ . Fully enclosed base features tamper resistant hardware. All 300 series stainless steel construction. 1-1/2" drain. 16-gauge deck features a raised marine edge with a 6" x 1-3/4" backsplash. Downward facing paper towel holder for 10" x 11" multi-fold paper towels. Features electronic-eye hand wash faucet with battery backup, eyewash faucet with tepid water temperature thermostatic mixing valve, soap dispenser (wall-mount battery powered for HSAP-10-EYE, deck-mount for HSAP-14-EYE), tail-piece, and p-trap.

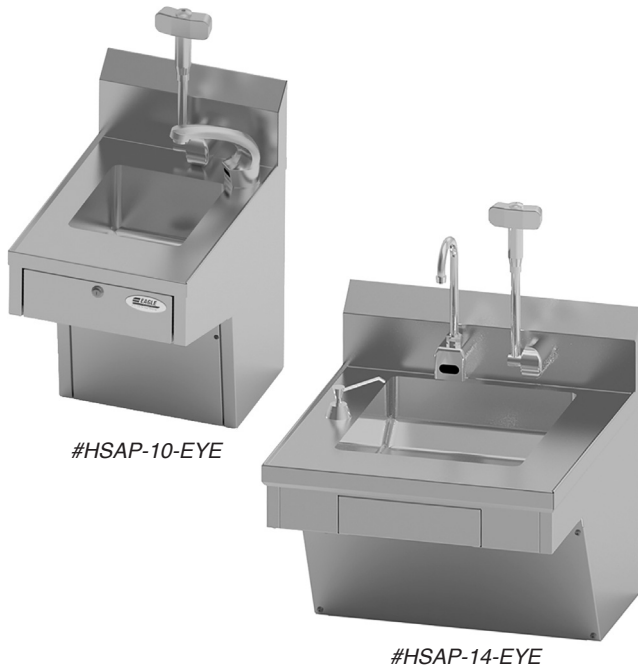

#HSAP-10-EYE

#HSAP-14-EYE

Item No.:	_____
Project No.:	_____
S.I.S. No.:	_____

## Hand Sinks with Eyewash

### MODELS:

- #HSAP-10-EYE
- #HSAP-14-EYE

### Design & Construction Features

- Fully enclosed skirt with access panel.
- Compact, space saving design.
- All 300 series stainless steel construction.
- Electric-eye faucet with battery backup. Requires 120-volt electrical outlet.
- Eyewash faucet OSHA, ANSI Z358.1 compliant: OSHA 29 CFR 1910.151(c). Includes OSHA-compliant safety sign and emergency inspection tag.
- Thermostatic mixing valve to ensure correct water temperature is maintained: 60°-100°F (15.6 -37.8°C).
- Mounting brackets with hardware are pre-installed in base/apron for quick installation of mixing valve and faucet control, braided stainless hoses included.
- Multi-fold paper towel holder designed for Georgia-Pacific #20887.

### #HSAP-10-EYE

- Wall-mounted, battery-powered type LTX-12 liquid soap dispenser.
- Deck-mounted electronic-eye faucet.
- Splash-mounted eyewash.

### #HSAP-14-EYE

- Deck-mounted 16-oz. soap dispenser.
- Splash-mounted electronic-eye faucet.
- Splash-mounted eyewash.

### EAGLE GROUP

100 Industrial Boulevard, Clayton, DE 19938-8903 USA  
 Phone: 302-653-3000 • 800-441-8440 • Fax: 302-653-2065  
[www.eaglegrp.com](http://www.eaglegrp.com)  
[www.eaglehmc.com](http://www.eaglehmc.com)

For custom configuration or fabrication needs, contact our **SpecFAB®** Division.  
 Phone: 302-653-3000 • Fax: 302-653-2065 • e-mail: [quotes@eaglegrp.com](mailto:quotes@eaglegrp.com)



EG20.57 Rev. 03/26

Spec sheets available for viewing, printing or downloading from our online literature library at our websites

Item No.: \_\_\_\_\_  
Project No.: \_\_\_\_\_  
S.I.S. No.: \_\_\_\_\_

# Hand Sinks with Eyewash

#HSAP-10-EYE

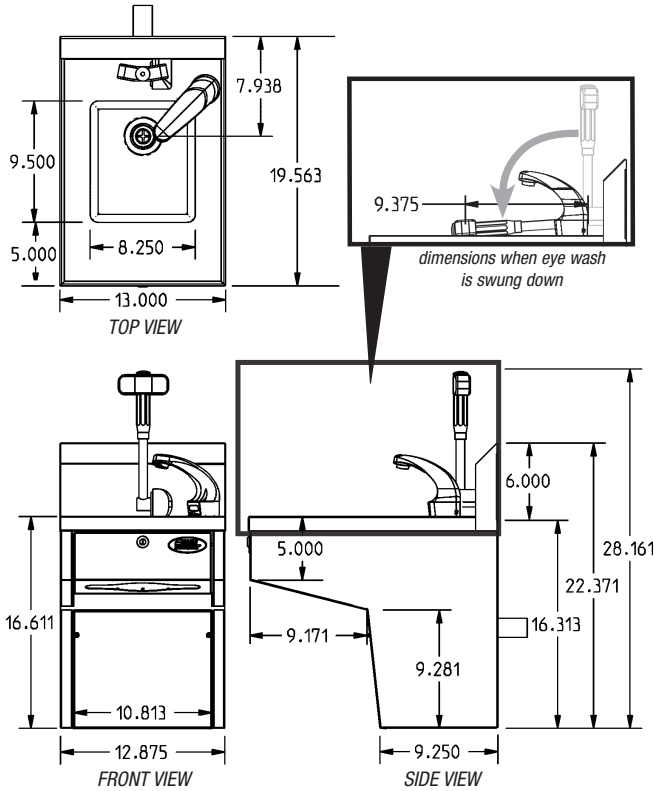

#HSAP-14-EYE

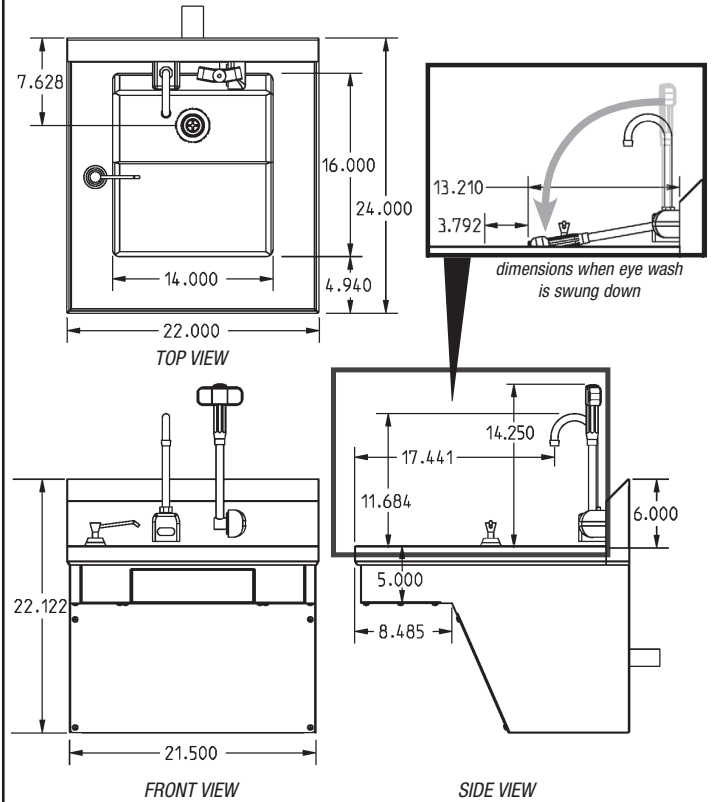

**Components used in HSAP-10-EYE**

Description	Manufacturer	Part #
Mixing valve	Guardian	G6020
Splash mount eyewash	Bradley	S19274HDR
Hand wash faucet	T&S	EC-3102

**Components used in HSAP-14-EYE**

Description	Manufacturer	Part #
Mixing valve	Guardian	G6020
Splash mount eyewash	Bradley	S19274HW
Hand wash faucet	Encore	K16-4000-MV

O.A. size (width x length x height)			bowl size (width x length x depth)			model #
in.	mm		in.	mm		
19 <sup>9</sup> / <sub>16</sub> " x 13" x 22 <sup>3</sup> / <sub>8</sub> "	497 x 330 x 568		9 <sup>1</sup> / <sub>2</sub> " x 8 <sup>1</sup> / <sub>4</sub> " x 5"	241 x 210 x 127		<b>HSAP-10-EYE</b>
24" x 22" x 22 <sup>1</sup> / <sub>2</sub> "	610 x 559 x 562		16" x 14" x 5"	406 x 356 x 127		<b>HSAP-14-EYE</b>

**EAGLE GROUP**  
100 Industrial Boulevard, Clayton, DE 19938-8903 USA  
Phone: 302-653-3000 or 800-441-8440 • Fax: 302-653-2065  
www.eaglegrp.com • www.eaglehmc.com

Printed in U.S.A.  
©2026 by Eagle Group

Rev. 03/26

Spec sheets available for viewing, printing or downloading from our online literature library at our websites

Although every attempt has been made to ensure the accuracy of the information provided, we cannot be held responsible for typographical or printing errors. Information and specifications are subject to change without notice. Please confirm at time of order.