



Profit from the Eagle Advantage®

Specification Sheet

Short Form Specifications

Eagle Quad-Adjust® Wire Shelf, model _____, EAGLEbrite® zinc, chrome, Valu-Master® Grey Epoxy, Valu-Gard® Green Epoxy, EAGLEgard® Green Epoxy with MICROGARD®, or stainless steel finish. Custom colors available. Patented QuadTruss® design. Specially designed for addition or removal of a shelf without disassembling entire shelf unit. Shelf features corners that interlock with post-mounted collars. Numerically grooved posts are 1" diameter.

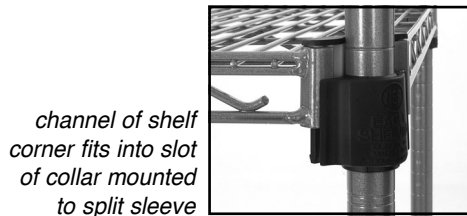

channel of shelf corner fits into slot of collar mounted to split sleeve

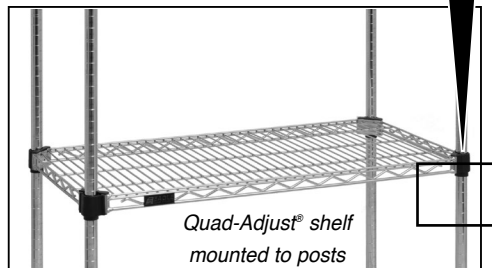

Quad-Adjust® shelf mounted to posts



Quad-Adjust® shelving unit

Options / Accessories

- Casters
- Ledges
- Dividers
- Foot plates
- Rods & tabs
- Aluminum split sleeves
- Shelf markers
- "S" hooks

EAGLE GROUP

100 Industrial Boulevard Clayton, DE 19938-8903 USA

Phone: 302-653-3000 • 800-441-8440

Fax: 302-653-2065

www.eaglegrp.com • www.eaglehmc.com

Item No.: _____
 Project No.: _____
 S.I.S. No.: _____

Quad-Adjust® Wire Shelving

MODELS:

- QA14* QA24* QAR21* P7-* P33-* P74-*
- QA18* QAR14* QAR24* P14-* P54-* P86-*
- QA21* QAR18* P18-* P63-*

* See charts for complete model numbers.

- Patented Quad-Truss® shelves (patent #5,390,803) for increased strength and durability.
- Shelves feature special interlocking corners that fit in slots of collars mounted to split sleeves, allowing addition or removal of a shelf without the need to disassemble the entire shelf unit. Patent #7,992,731.
- Tapered split sleeves create a positive lock that becomes stronger as the load increases.
- Posts are numbered in increments of 1" (25mm) to ensure fast and level assembly.
- Leveling feet are provided to help compensate for uneven floor surfaces.
- Shelf utilizes a pincer-type design with the mat wire sandwiched between the two top truss wires, adding significant strength and distributing the entire load without stress and strain on the welds.
- Finishes available are EAGLEbrite® zinc, chrome, Valu-Master® grey epoxy, Valu-Gard® green epoxy, EAGLEgard® green epoxy with MICROGARD®, and stainless steel. Custom colors available.
- Quad-Adjust® shelving units must utilize standard shelves (spec sheet #EG01.00) for top and bottom shelves.

Weight capacities:

- Shelves up to 48" (1219mm) in length can support an evenly distributed static load of 800 lbs. (362.9 kg).
- Shelves of 60" and 72" (1524 and 1829mm) length can support an evenly distributed static load of 600 lbs. (272.2 kg).
- IMPORTANT: Stationary units should not exceed 2400 lbs. (1088.6 kg) per set of four posts.
- IMPORTANT: Maximum load for mobile units is to be one the following, whichever is less: – 3 times the weight rating for one caster, or– 1000 lbs. (453.6 kg) per set of four posts.

Certifications / Approvals



AutoQuotes



For custom configuration or fabrication needs, contact our SpecFAB® Division.

Phone: 302-653-3000 • Fax: 302-653-2065 • e-mail: quotes@eaglegrp.com

EG01.14A Rev. 04/26

Spec sheets available for viewing, printing or downloading from our online literature library at www.eaglegrp.com



Item No.: _____
 Project No.: _____
 S.I.S. No.: _____

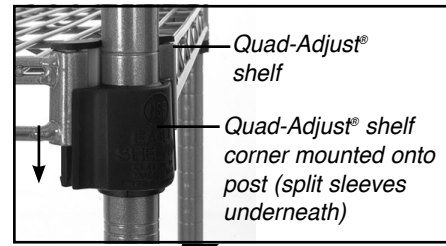
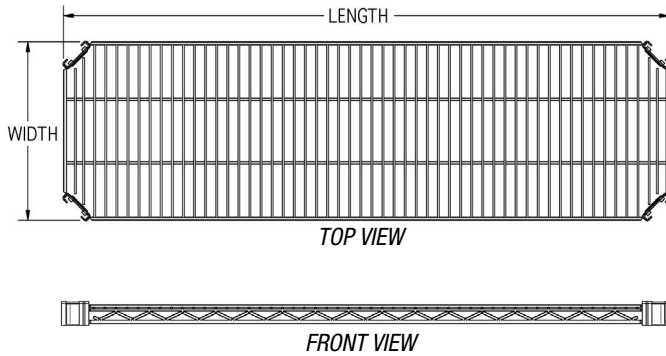

To specify finish (available for all components listed), place the corresponding suffix after the model number.
 suffix "Z" = EAGLEbrite® suffix "V" = Valu-Master® Gray Epoxy suffix "E" = EAGLEgard® Green Epoxy
 suffix "C" = Chrome suffix "VG" = Valu-Gard® Green Epoxy suffix "S" = stainless steel

Shelves

model #	width x length		weight	
	in.	mm	lb.	kg
QA1424	14" x 24"	356 x 610	6	2.7
QA1430	14" x 30"	356 x 762	7	3.2
QA1436	14" x 36"	356 x 914	8	3.6
QA1442	14" x 42"	356 x 1067	9	4.1
QA1448	14" x 48"	356 x 1219	10	4.6
QA1454	14" x 54"	356 x 1372	12	5.5
QA1460	14" x 60"	356 x 1524	14	6.4
QA1472	14" x 72"	356 x 1829	17	7.7
QA1824	18" x 24"	457 x 610	7	3.2
QA1830	18" x 30"	457 x 762	8	3.6
QA1836	18" x 36"	457 x 914	9	4.1
QA1842	18" x 42"	457 x 1067	11	5.0
QA1848	18" x 48"	457 x 1219	12	5.5
QA1854	18" x 54"	457 x 1372	15	6.8
QA1860	18" x 60"	457 x 1524	17	7.7
QA1872	18" x 72"	457 x 1829	20	9.1
QA2124	21" x 24"	533 x 610	8	3.6
QA2130	21" x 30"	533 x 762	9	4.1
QA2136	21" x 36"	533 x 914	11	5.0
QA2142	21" x 42"	533 x 1067	12	5.5
QA2148	21" x 48"	533 x 1219	14	6.4
QA2154	21" x 54"	533 x 1372	16	7.3
QA2160	21" x 60"	533 x 1524	18	8.2
QA2172	21" x 72"	533 x 1829	24	10.9
QA2424	24" x 24"	610 x 610	9	4.1
QA2430	24" x 30"	610 x 762	11	5.0
QA2436	24" x 36"	610 x 914	13	5.9
QA2442	24" x 42"	610 x 1067	15	6.8
QA2448	24" x 48"	610 x 1219	16	7.3
QA2454	24" x 54"	610 x 1372	19	8.6
QA2460	24" x 60"	610 x 1524	21	9.5
QA2472	24" x 72"	610 x 1829	26	11.8

Reverse Mat Shelves

model #	width x length		weight	
	in.	mm	lb.	kg
QAR1424	14" x 24"	356 x 610	6	2.7
QAR1436	14" x 36"	356 x 914	8	3.6
QAR1448	14" x 48"	356 x 1219	10	4.6
QAR1824	18" x 24"	457 x 610	7	3.2
QAR1836	18" x 36"	457 x 914	9	4.1
QAR1848	18" x 48"	457 x 1219	12	5.5
QAR2124	21" x 24"	533 x 610	8	3.6
QAR2136	21" x 36"	533 x 914	11	5.0
QAR2148	21" x 48"	533 x 1219	14	6.4
QAR2424	24" x 24"	610 x 610	9	4.1
QAR2436	24" x 36"	610 x 914	13	5.9
QAR2448	24" x 48"	610 x 1219	16	7.3

Posts

Numerically grooved in 1" (25mm) increments. Includes post cap and leveling bolt.

model #	height		weight	
	in.	mm	lb.	kg
P7-	7"	178	1.0	0.5
P14-	14"	356	1.0	0.5
P18-	18"	457	1.5	0.7
P33-	33"	838	2.0	0.9
P54-	54"	1372	3.0	1.4
P63-	63"	1600	3.5	1.6
P74-	74"	1880	4.0	1.8
P86-	86"	2184	5.0	2.3

- Notes:
- EAGLEbrite® posts are clear epoxy coated for use in dry or wet environments.
 - MICROGARD® antimicrobial protection standard on all EAGLEgard® posts.
 - For mobile application, add prefix "C" to model number. Example: CP14-E. See Spec Sheet EG01.05 for information about casters available.

EAGLE GROUP
 100 Industrial Boulevard, Clayton, DE 19938-8903 USA
 Phone: 302-653-3000 or 800-441-8440 • Fax: 302-653-2065
 www.eaglegrp.com • www.eaglehmc.com

Printed in U.S.A.
 ©2026 by Eagle Group

Rev. 04/26

Spec sheets available for viewing, printing or downloading from our online literature library at www.eaglegrp.com

Although every attempt has been made to ensure the accuracy of the information provided, we cannot be held responsible for typographical or printing errors. Information and specifications are subject to change without notice. Please confirm at time of order.