



Profit from the Eagle Advantage®

Specification Sheet

Short Form Specifications

Eagle Spec-Master® Grab-N-Go Single-Side Shelf Unit, model _____ . Stainless steel open base cabinet with 6" deep insulated pan, 5" plate casters (two with brake), 1" drain with valve. Available with shelves with single- or double-tier. Includes POS end shelf and push handle. Optional tray slides available.

Item No.:	_____
Project No.:	_____
S.I.S. No.:	_____

Spec-Master® Grab-N-Go Single-Side Shelf Units

MODELS:

- | | |
|--|--|
| <input type="checkbox"/> INS-20B-M-1S | <input type="checkbox"/> INS-20B-M-2S |
| <input type="checkbox"/> INS-30B-M-1S | <input type="checkbox"/> INS-30B-M-2S |
| <input type="checkbox"/> INS-40B-M-1S | <input type="checkbox"/> INS-40B-M-2S |
| <input type="checkbox"/> INS-50B-M-1S | <input type="checkbox"/> INS-50B-M-2S |
| <input type="checkbox"/> INS-60B-M-1S | <input type="checkbox"/> INS-60B-M-2S |



#INS-40B-M-1S
(shown with optional #TS-DB-HT4 tray slides)

Design and Construction Features

- Stainless steel open base body
- 6" (152mm) deep insulated food pan
- 5" (127mm) casters, two with brake
- Push handle
- POS shelf with drop brackets

Options / Accessories

- Tray slide - see EG30.20A

EAGLE GROUP
 100 Industrial Boulevard, Clayton, DE 19938-8903 USA
 Phone: 302-653-3000 • 800-441-8440 • Fax: 302-653-2065
www.eaglegrp.com
www.eaglegrp.com



For custom configuration or fabrication needs, contact our **SpecFAB® Division**.
 Phone: 302-653-3000 • Fax: 302-653-2065 • e-mail: quotes@eaglegrp.com

EG33.28A Rev. 02/25

Spec sheets available for viewing, printing or downloading from our online literature library at our websites



Item No.: _____
 Project No.: _____
 S.I.S. No.: _____

Spec-Master® Grab-N-Go Single-Side Shelf Units

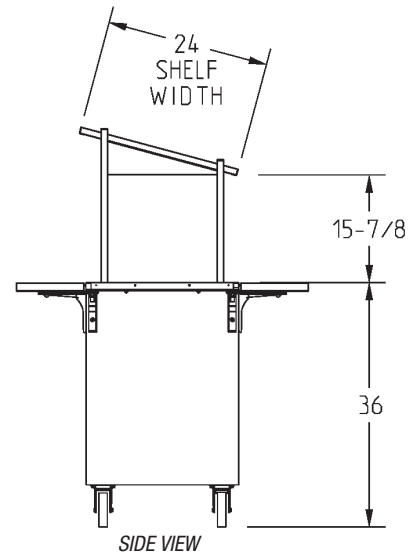
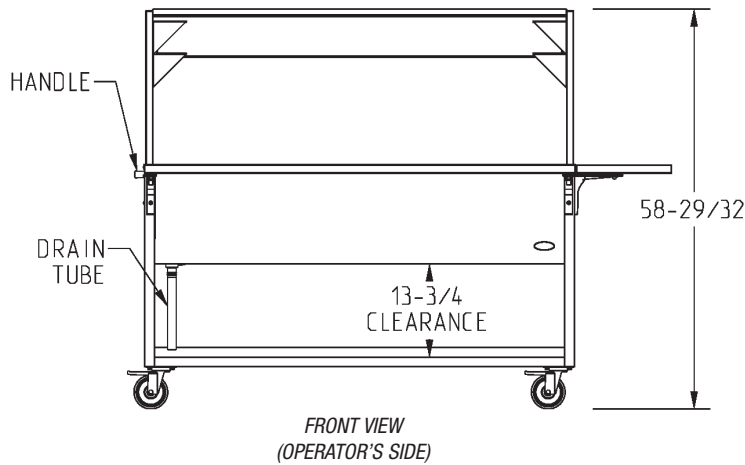
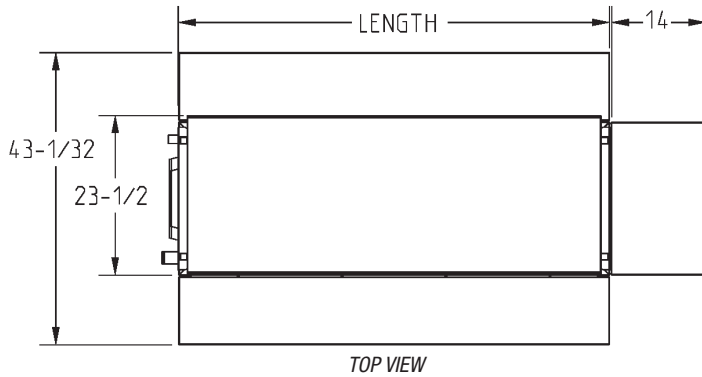

# of openings	length*		Single-Tier	Double-Tier
	in.	mm	model #	model #
2	33"	914	INS-2OB-M-1S	INS-2OB-M-2S
3	48"	1270	INS-3OB-M-1S	INS-3OB-M-2S
4	63 1/2"	1626	INS-4OB-M-1S	INS-4OB-M-2S
5	78"	1981	INS-5OB-M-1S	INS-5OB-M-2S
6	96"	2438	INS-6OB-M-1S	INS-6OB-M-2S

* Length excludes POS end shelf.

EAGLE GROUP
 100 Industrial Boulevard, Clayton, DE 19938-8903 USA
 Phone: 302-653-3000 or 800-441-8440 • Fax: 302-653-2065
 www.eaglegrp.com • www.eaglehmc.com

Printed in U.S.A.
 ©2025 by Eagle Group

Rev. 02/25

Spec sheets available for viewing, printing or downloading from our online literature library at our websites

Although every attempt has been made to ensure the accuracy of the information provided, we cannot be held responsible for typographical or printing errors. Information and specifications are subject to change without notice. Please confirm at time of order.



Profit from the Eagle Advantage®

Specification Sheet

Short Form Specifications

Eagle Spec-Master® Grab-N-Go Double-Side Shelf Unit, model _____ . Stainless steel open base cabinet with 6"-deep insulated pan, 5" plate casters (two with brake), 1" drain with valve. Available with double-sided shelves with single- or double-tier. Includes POS end shelf and push handle. Optional tray slides available.



#INS-4OB-M-1D
(shown with optional #TS-DB-HT4 tray slides)

Item No.: _____
Project No.: _____
S.I.S. No.: _____

Spec-Master® Grab-N-Go Double-Side Shelf Units

MODELS:

- INS-20B-M-1D* *INS-20B-M-2D*
- INS-30B-M-1D* *INS-30B-M-2D*
- INS-40B-M-1D* *INS-40B-M-2D*
- INS-50B-M-1D* *INS-50B-M-2D*
- INS-60B-M-1D* *INS-60B-M-2D*

Design and Construction Features

- Stainless steel open base body
- 6" (152mm) deep insulated food pan
- 5" (127mm) casters, two with brake
- Push handle
- POS shelf with drop brackets

Options / Accessories

- Tray slide - see EG30.20A

EAGLE GROUP

100 Industrial Boulevard, Clayton, DE 19938-8903 USA
Phone: 302-653-3000 • 800-441-8440 • Fax: 302-653-2065
www.eaglegrp.com
www.eaglegrp.com

For custom configuration or fabrication needs, contact our **SpecFAB® Division**.
Phone: 302-653-3000 • Fax: 302-653-2065 • e-mail: quotes@eaglegrp.com



EG33.28B Rev. 02/25

Spec sheets available for viewing, printing or downloading from our online literature library at our websites

Eagle Foodservice Equipment, Eagle MHC, and SpecFAB® are divisions of Eagle Group. ©2025 by the Eagle Group



Item No.: _____
 Project No.: _____
 S.I.S. No.: _____

Spec-Master® Grab-N-Go Double-Side Shelf Units

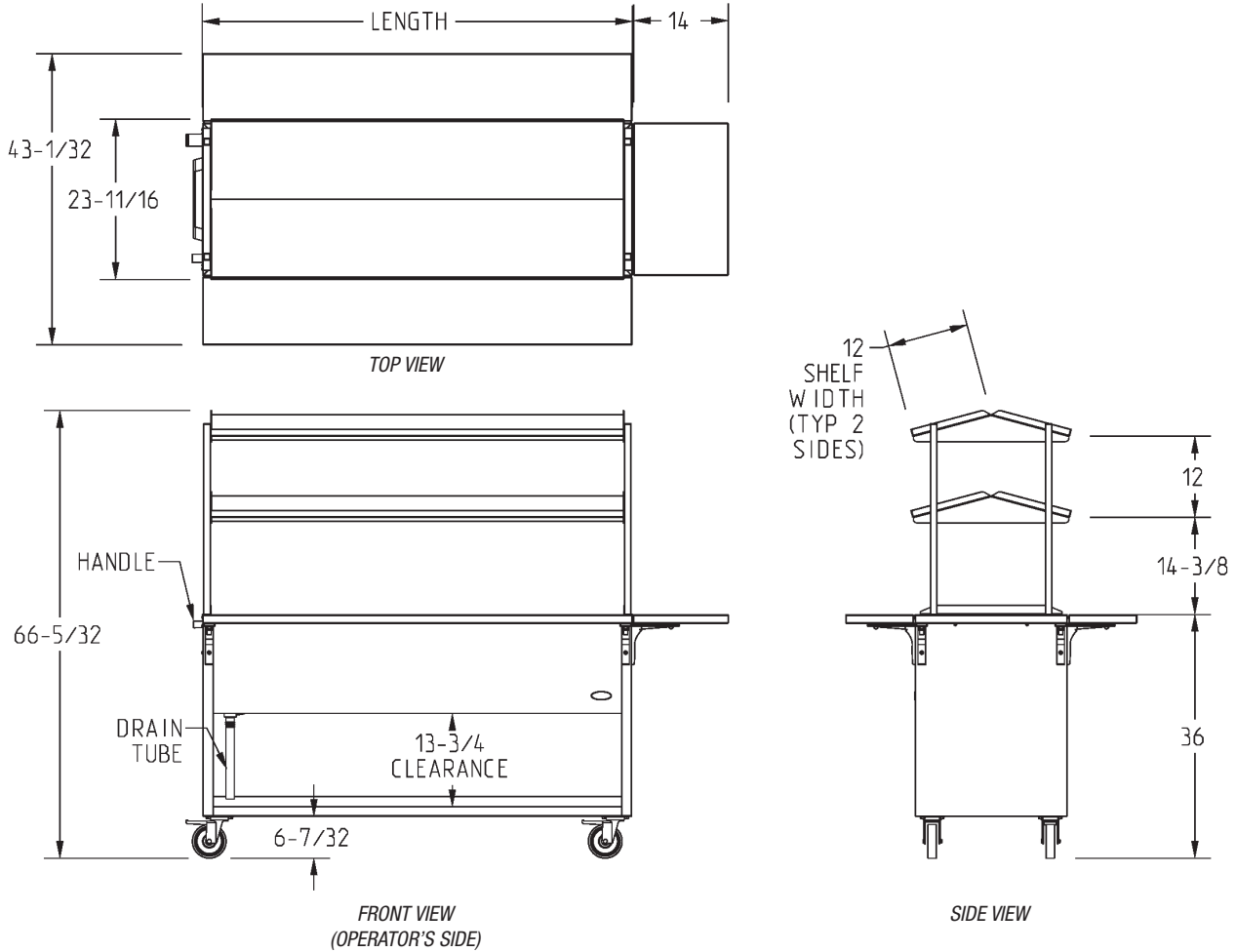

# of openings	length*		Single-Tier	Double-Tier
	in.	mm	model #	model #
2	33"	914	INS-2OB-M-1D	INS-2OB-M-2D
3	48"	1270	INS-3OB-M-1D	INS-3OB-M-2D
4	63 1/2"	1626	INS-4OB-M-1D	INS-4OB-M-2D
5	78"	1981	INS-5OB-M-1D	INS-5OB-M-2D
6	96"	2438	INS-6OB-M-1D	INS-6OB-M-2D

* Length excludes POS end shelf.

EAGLE GROUP
 100 Industrial Boulevard, Clayton, DE 19938-8903 USA
 Phone: 302-653-3000 or 800-441-8440 • Fax: 302-653-2065
 www.eaglegrp.com • www.eaglehmc.com

Printed in U.S.A.
 ©2025 by Eagle Group

Rev. 02/25

Spec sheets available for viewing, printing or downloading from our online literature library at our websites

Although every attempt has been made to ensure the accuracy of the information provided, we cannot be held responsible for typographical or printing errors. Information and specifications are subject to change without notice. Please confirm at time of order.



Profit from the Eagle Advantage®

Specification Sheet

Short Form Specifications

Eagle Spec-Master® Grab-N-Go Buffet Unit, model _____ . Stainless steel open base cabinet with 6"-deep insulated pan, 5" plate casters (two with brake), 1" drain with valve. Available with single- or double-sided buffet shields. Includes POS end shelf and push handle. Optional tray slides available.



#INS-4OB-M-BS2
(shown with optional #TS-DB-HT4 tray slides)

Item No.: _____
Project No.: _____
S.I.S. No.: _____

Spec-Master® Grab-N-Go Buffet Units

MODELS:

- INS-2OB-M-BS1
- INS-3OB-M-BS1
- INS-4OB-M-BS1
- INS-5OB-M-BS1
- INS-6OB-M-BS1
- INS-2OB-M-BS2
- INS-3OB-M-BS2
- INS-4OB-M-BS2
- INS-5OB-M-BS2
- INS-6OB-M-BS2

Design and Construction Features

- Stainless steel open base body
- 6" (152mm) deep insulated food pan
- 5" (127mm) casters, two with brake
- Push handle
- POS shelf with drop brackets

Options / Accessories

- Tray slide - see EG30.20A

EAGLE GROUP
100 Industrial Boulevard, Clayton, DE 19938-8903 USA
Phone: 302-653-3000 • 800-441-8440 • Fax: 302-653-2065
www.eaglegrp.com
www.eaglegrp.com

For custom configuration or fabrication needs, contact our **SpecFAB® Division**.
Phone: 302-653-3000 • Fax: 302-653-2065 • e-mail: quotes@eaglegrp.com



EG33.28C Rev. 02/25

Spec sheets available for viewing, printing or downloading from our online literature library at our websites

Eagle Foodservice Equipment, Eagle MHC, and SpecFAB® are divisions of Eagle Group. ©2025 by the Eagle Group



Item No.: _____
 Project No.: _____
 S.I.S. No.: _____

Spec-Master® Grab-N-Go Buffet Units

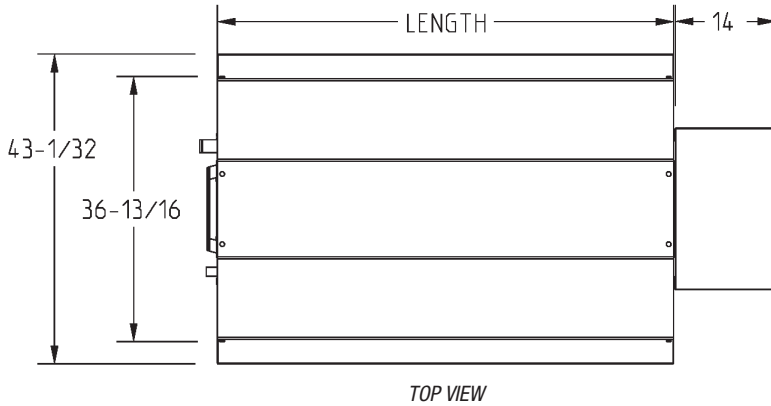

TOP VIEW

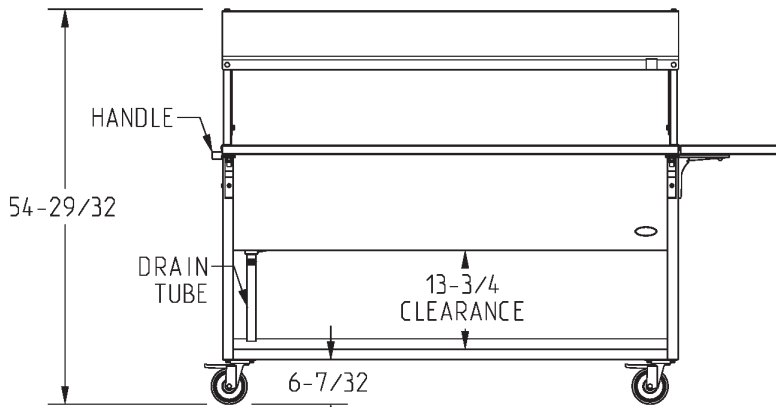

FRONT VIEW
(OPERATOR'S SIDE)

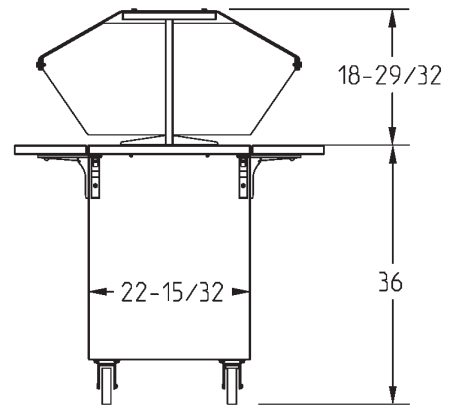

SIDE VIEW

# of openings	length*		Single-Sided	Double-Sided
	in.	mm	model #	model #
2	33"	914	INS-2OB-M-BS1	INS-2OB-M-BS2
3	48"	1270	INS-3OB-M-BS1	INS-3OB-M-BS2
4	63 1/2"	1626	INS-4OB-M-BS1	INS-4OB-M-BS2
5	78"	1981	INS-5OB-M-BS1	INS-5OB-M-BS2
6	96"	2438	INS-6OB-M-BS1	INS-6OB-M-BS2

* Length excludes POS end shelf.

EAGLE GROUP
 100 Industrial Boulevard, Clayton, DE 19938-8903 USA
 Phone: 302-653-3000 or 800-441-8440 • Fax: 302-653-2065
 www.eaglegrp.com • www.eaglehmc.com

Printed in U.S.A.
 ©2025 by Eagle Group

Rev. 02/25

Spec sheets available for viewing, printing or downloading from our online literature library at our websites

Although every attempt has been made to ensure the accuracy of the information provided, we cannot be held responsible for typographical or printing errors. Information and specifications are subject to change without notice. Please confirm at time of order.