



Profit from the Eagle Advantage®

Specification Sheet

Short Form Specifications

Eagle Spec-GUARD™ Self-Service Food Guard, model _____ . Self-service food shield designed to meet NSF requirements. Front allows maximum customer access to the food product, while maximizing protection. Rear allows full access by the kitchen staff for replenishing product. Available in single- or double-tier models.



#DCS2-BF-ST1



#DCS2-BF-DT1

Item No.:	_____
Project No.:	_____
S.I.S. No.:	_____

Spec-GUARD™ Self-Service Food Guards

MODELS:

- | | |
|--------------------------------------|--------------------------------------|
| <input type="checkbox"/> DCS2-BF-ST1 | <input type="checkbox"/> DCS2-BF-DT1 |
| <input type="checkbox"/> DCS3-BF-ST1 | <input type="checkbox"/> DCS3-BF-DT1 |
| <input type="checkbox"/> DCS4-BF-ST1 | <input type="checkbox"/> DCS4-BF-DT1 |
| <input type="checkbox"/> DCS5-BF-ST1 | <input type="checkbox"/> DCS5-BF-DT1 |
| <input type="checkbox"/> DCS6-BF-ST1 | <input type="checkbox"/> DCS6-BF-DT1 |

Design and Construction Features

- Fixed glass panels mounted on stainless steel standoffs
- 1" (25mm) stainless steel tubular frame
- Die-cast aluminum mounting plates with stainless steel covers
- 3/4" (19mm) radius on glass panels
- 3/8" (10mm)-thick top glass
- 1/4" (6mm)-thick front and side glass

Options / Accessories

- Heat lamps
- Lights
- 3 5/8" round mounting plate
- 3" Oval mounting plate
- 3" Oval offset mounting plate
- 2" x 8" rectangular mounting plate
- 3-point anchor
- Custom lengths available

⚠ WARNING:

This product can expose you to chemicals including Chromium, which is known to the state of California to cause cancer and birth defects or other reproductive harm. For more information, go to www.P65Warnings.ca.gov.

EAGLE GROUP

100 Industrial Boulevard, Clayton, DE 19938-8903 USA
Phone: 302-653-3000 • 800-441-8440 • Fax: 302-653-2065
www.eaglegrp.com
www.eaglemhc.com

For custom configuration or fabrication needs, contact our SpecFAB® Division.
Phone: 302-653-3000 • Fax: 302-653-2065 • e-mail: quotes@eaglegrp.com



EG33.27A Rev. 02/25

Spec sheets available for viewing, printing or downloading from our online literature library at our websites

Eagle Foodservice Equipment, Eagle MHC, and SpecFAB® are divisions of Eagle Group. ©2025 by the Eagle Group



Item No.: _____
 Project No.: _____
 S.I.S. No.: _____

Spec-GUARD™ Self-Service Food Guards

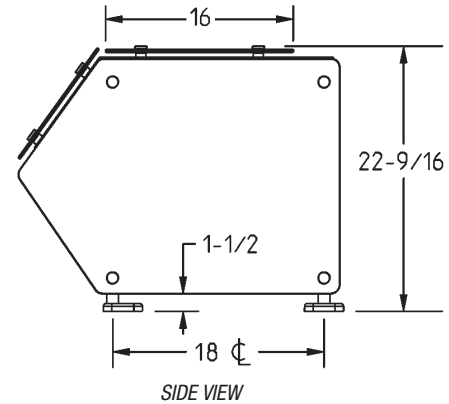
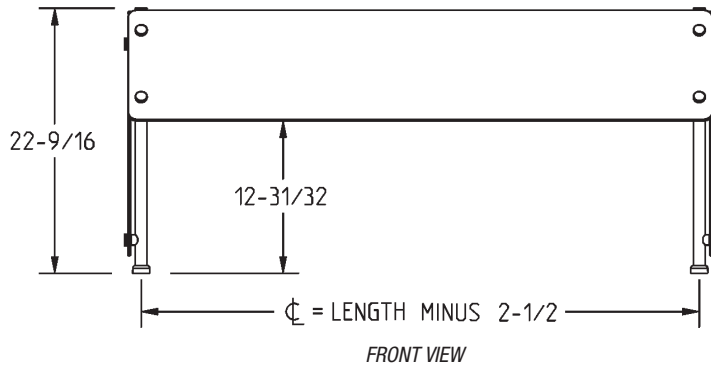
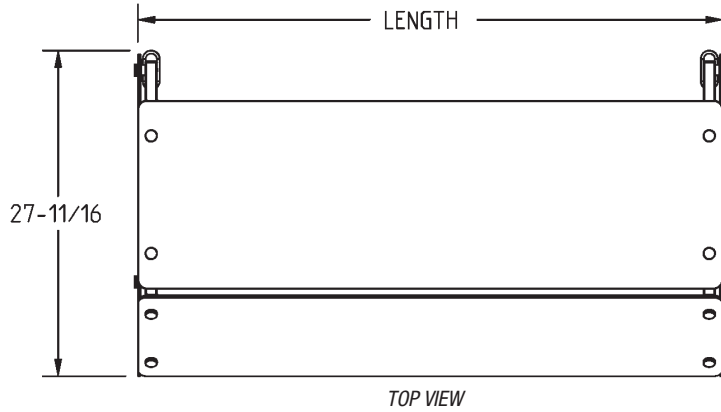

(Single-tier unit shown)

fits Series	length		weight		model #	weight		model #
	in.	mm	lbs.	kg		lbs.	kg	
DCS2	36"	914	302	137.0	DCS2-BF-ST1	385	174.6	DCS2-BF-DT1
DCS3	50"	1270	329	149.2	DCS3-BF-ST1	419	190.1	DCS3-BF-DT1
DCS4	64"	1626	363	164.7	DCS4-BF-ST1	464	210.5	DCS4-BF-DT1
DCS5	78"	1981	390	176.9	DCS5-BF-ST1	497	225.4	DCS5-BF-DT1
DCS6	96"	2438	423	191.9	DCS6-BF-ST1	534	242.2	DCS6-BF-DT1

EAGLE GROUP
 100 Industrial Boulevard, Clayton, DE 19938-8903 USA
 Phone: 302-653-3000 or 800-441-8440 • Fax: 302-653-2065
 www.eaglegrp.com • www.eaglehmc.com

Printed in U.S.A.
 ©2025 by Eagle Group

Rev. 02/25

Spec sheets available for viewing, printing or downloading from our online literature library at our websites

Although every attempt has been made to ensure the accuracy of the information provided, we cannot be held responsible for typographical or printing errors. Information and specifications are subject to change without notice. Please confirm at time of order.



Profit from the Eagle Advantage®

Specification Sheet

Short Form Specifications

Eagle Spec-GUARD™ Self-Service Buffet Food Guard, model _____, Self-service buffet food shield designed to meet NSF requirements. Front and rear allow maximum customer access to the food product while maximizing protection. Available in single- or double-tier models.

Item No.:	_____
Project No.:	_____
S.I.S. No.:	_____

Spec-GUARD™ Self-Service Buffet Food Guards

MODELS:

- | | |
|--------------------------------------|--------------------------------------|
| <input type="checkbox"/> DCS2-BF-ST2 | <input type="checkbox"/> DCS2-BF-DT2 |
| <input type="checkbox"/> DCS3-BF-ST2 | <input type="checkbox"/> DCS3-BF-DT2 |
| <input type="checkbox"/> DCS4-BF-ST2 | <input type="checkbox"/> DCS4-BF-DT2 |
| <input type="checkbox"/> DCS5-BF-ST2 | <input type="checkbox"/> DCS5-BF-DT2 |
| <input type="checkbox"/> DCS6-BF-ST2 | <input type="checkbox"/> DCS6-BF-DT2 |



#DCS2-BF-ST2

Design and Construction Features

- Fixed glass panels mounted on stainless steel standoffs
- 1" (25mm) stainless steel tubular frame
- Die-cast aluminum mounting plates with stainless steel covers
- 3/4" (19mm) radius on glass panels
- 3/8" (10mm)-thick top glass
- 1/4" (6mm)-thick front and side glass



#DCS2-BF-DT2

Options / Accessories

- Heat lamps
- Lights
- 3 5/8" round mounting plate
- 3" Oval mounting plate
- 3" Oval offset mounting plate
- 2" x 8" rectangular mounting plate
- 3-point anchor
- Custom lengths available

⚠ WARNING:

This product can expose you to chemicals including Chromium, which is known to the state of California to cause cancer and birth defects or other reproductive harm. For more information, go to www.P65Warnings.ca.gov.

EAGLE GROUP

100 Industrial Boulevard, Clayton, DE 19938-8903 USA
 Phone: 302-653-3000 • 800-441-8440 • Fax: 302-653-2065
www.eaglegrp.com
www.eaglemhc.com

For custom configuration or fabrication needs, contact our SpecFAB® Division.
 Phone: 302-653-3000 • Fax: 302-653-2065 • e-mail: quotes@eaglegrp.com



EG33.27B Rev. 02/25

Spec sheets available for viewing, printing or downloading from our online literature library at our websites

Eagle Foodservice Equipment, Eagle MHC, and SpecFAB® are divisions of Eagle Group. ©2025 by the Eagle Group



Item No.: _____
 Project No.: _____
 S.I.S. No.: _____

Spec-GUARD™ Self-Service Buffet Food Guards

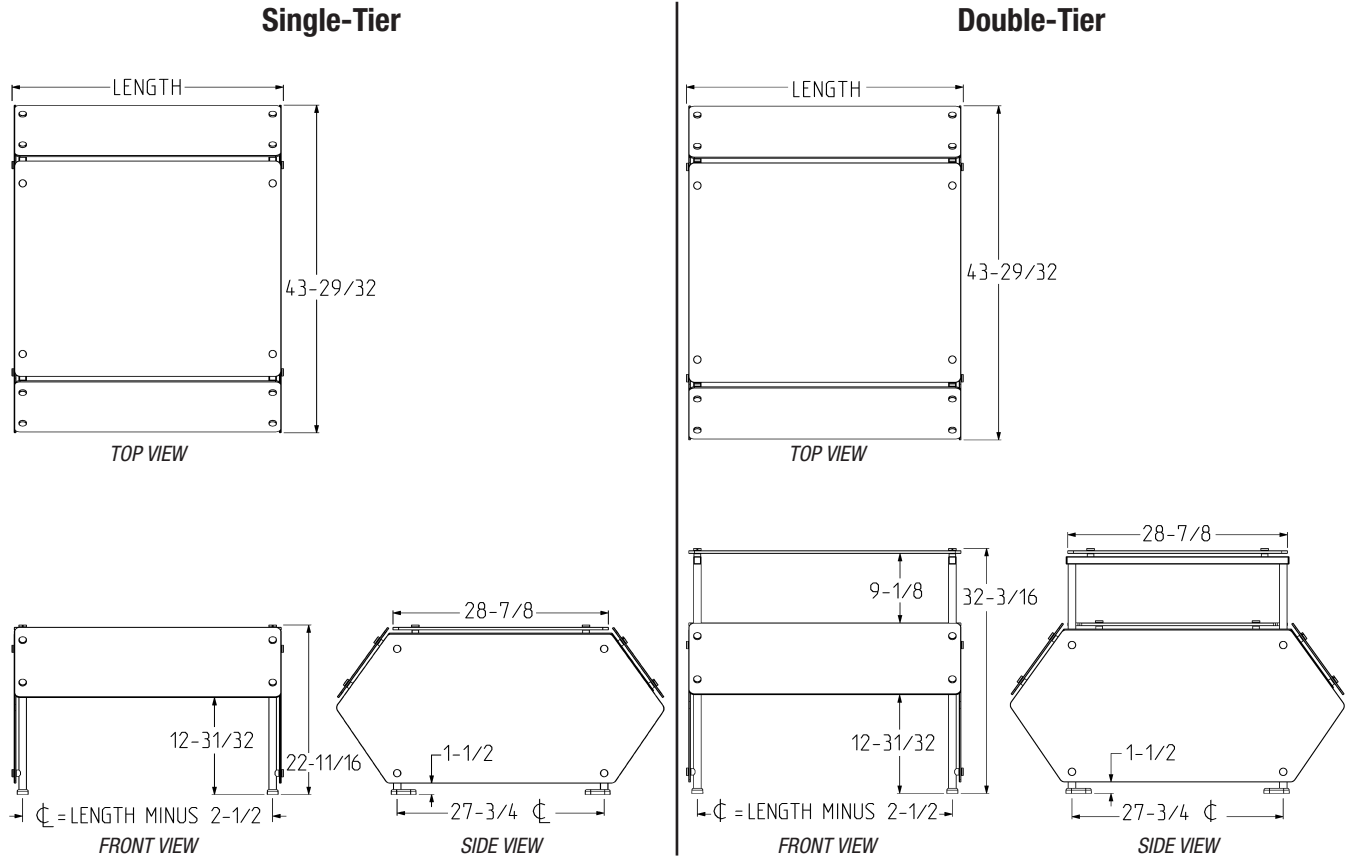

fits Series	length		weight		model #	weight		model #
	in.	mm	lbs.	kg		lbs.	kg	
DCS2	36"	914	313	142.0	DCS2-BF-ST2	399	181.0	DCS2-BF-DT2
DCS3	50"	1270	349	158.3	DCS3-BF-ST2	448	203.2	DCS3-BF-DT2
DCS4	64"	1626	400	181.4	DCS4-BF-ST2	515	233.6	DCS4-BF-DT2
DCS5	78"	1981	435	197.3	DCS5-BF-ST2	563	255.4	DCS5-BF-DT2
DCS6	96"	2438	476	215.9	DCS6-BF-ST2	624	283.1	DCS6-BF-DT2

EAGLE GROUP
 100 Industrial Boulevard, Clayton, DE 19938-8903 USA
 Phone: 302-653-3000 or 800-441-8440 • Fax: 302-653-2065
 www.eaglegrp.com • www.eaglehmc.com

Printed in U.S.A.
 ©2025 by Eagle Group

Rev. 02/25

Spec sheets available for viewing, printing or downloading from our online literature library at our websites

Although every attempt has been made to ensure the accuracy of the information provided, we cannot be held responsible for typographical or printing errors. Information and specifications are subject to change without notice. Please confirm at time of order.



Profit from the Eagle Advantage®

Specification Sheet

Short Form Specifications

Eagle Spec-GUARD™ Cafeteria Food Guards with Glass or Solid Top, model _____. Cafeteria food shield designed to meet NSF requirements. Front allows maximum customer view of the food product while maximizing protection. Rear allows full access by the kitchen staff for replenishing product.



#DCS2-CA-GT

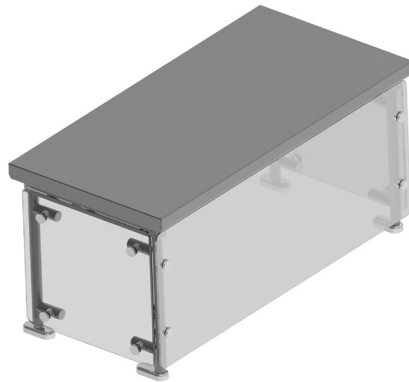

#DCS2-CA-MT

Item No.:	_____
Project No.:	_____
S.I.S. No.:	_____

Spec-GUARD™ Cafeteria Food Guards with Glass or Solid Top

MODELS:

- | | |
|-------------------------------------|-------------------------------------|
| <input type="checkbox"/> DCS2-CA-GT | <input type="checkbox"/> DCS2-CA-MT |
| <input type="checkbox"/> DCS3-CA-GT | <input type="checkbox"/> DCS3-CA-MT |
| <input type="checkbox"/> DCS4-CA-GT | <input type="checkbox"/> DCS4-CA-MT |
| <input type="checkbox"/> DCS5-CA-GT | <input type="checkbox"/> DCS5-CA-MT |
| <input type="checkbox"/> DCS6-CA-GT | <input type="checkbox"/> DCS6-CA-MT |

Design and Construction Features

- Fixed glass panels mounted on stainless steel standoffs
- 1" (25mm) stainless steel tubular frame
- Die-cast aluminum mounting plates with stainless steel covers
- 3/4" (19mm) radius on glass panels
- 3/8" (10mm)-thick top glass
- 1/4" (6mm)-thick front and side glass
- End glass included

Options / Accessories

- Heat lamps
- Lights
- 3 5/8" round mounting plate
- 3" Oval mounting plate
- 3" Oval offset mounting plate
- 2" x 8" rectangular mounting plate
- 3-point anchor
- Custom lengths available

⚠ WARNING:

This product can expose you to chemicals including Chromium, which is known to the state of California to cause cancer and birth defects or other reproductive harm. For more information, go to www.P65Warnings.ca.gov.

EAGLE GROUP

100 Industrial Boulevard, Clayton, DE 19938-8903 USA
Phone: 302-653-3000 • 800-441-8440 • Fax: 302-653-2065
www.eaglegrp.com
www.eaglemhc.com

For custom configuration or fabrication needs, contact our SpecFAB® Division.
Phone: 302-653-3000 • Fax: 302-653-2065 • e-mail: quotes@eaglegrp.com



EG33.27C Rev. 02/25

Spec sheets available for viewing, printing or downloading from our online literature library at our websites

Eagle Foodservice Equipment, Eagle MHC, and SpecFAB® are divisions of Eagle Group. ©2025 by the Eagle Group



Item No.: _____
 Project No.: _____
 S.I.S. No.: _____

Spec-GUARD™ Cafeteria Food Guards with Glass or Solid Top

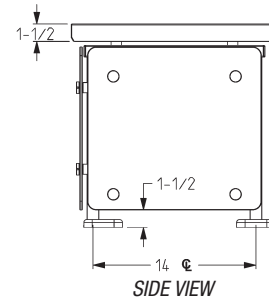
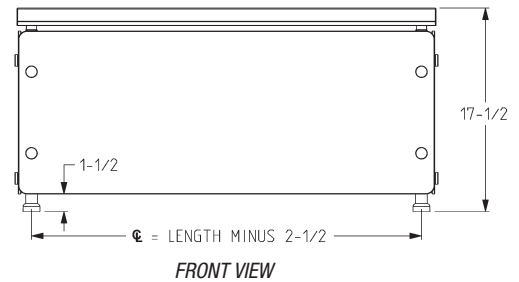
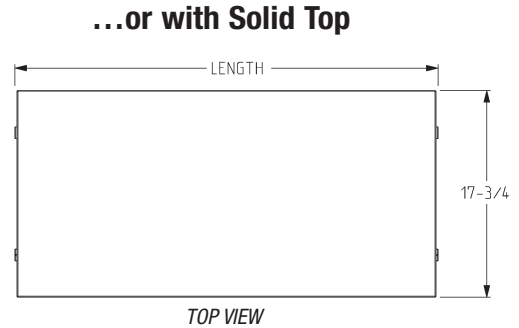
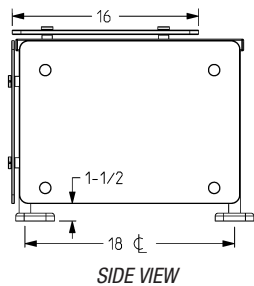
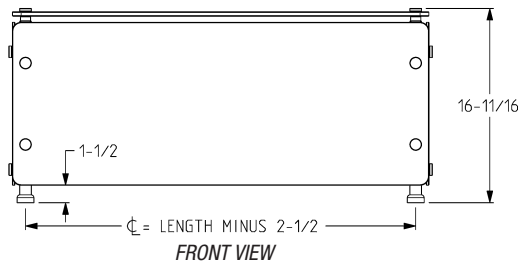
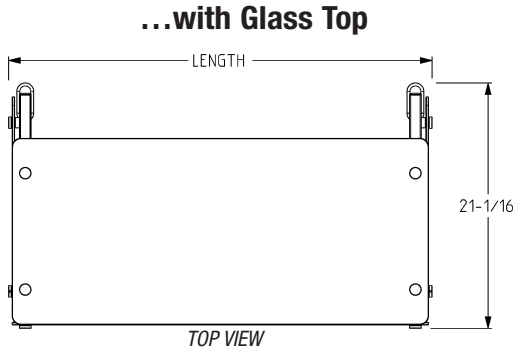

fits Series	length		weight		model #	weight		model #
	in.	mm	lbs.	kg		lbs.	kg	
DCS2	36"	914	217	98.4	<i>DCS2-CA-GT</i>	226	102.5	<i>DCS2-CA-MT</i>
DCS3	50"	1270	243	110.2	<i>DCS3-CA-GT</i>	255	115.7	<i>DCS3-CA-MT</i>
DCS4	64"	1626	276	125.2	<i>DCS4-CA-GT</i>	292	132.5	<i>DCS4-CA-MT</i>
DCS5	78"	1981	308	139.7	<i>DCS5-CA-GT</i>	321	145.6	<i>DCS5-CA-MT</i>
DCS6	96"	2438	342	155.1	<i>DCS6-CA-GT</i>	355	161.0	<i>DCS6-CA-MT</i>

EAGLE GROUP
 100 Industrial Boulevard, Clayton, DE 19938-8903 USA
 Phone: 302-653-3000 or 800-441-8440 • Fax: 302-653-2065
 www.eaglegrp.com • www.eaglehmc.com

Printed in U.S.A.
 ©2025 by Eagle Group

Rev. 02/25

Spec sheets available for viewing, printing or downloading from our online literature library at our websites

Although every attempt has been made to ensure the accuracy of the information provided, we cannot be held responsible for typographical or printing errors. Information and specifications are subject to change without notice. Please confirm at time of order.



Profit from the Eagle Advantage®

Specification Sheet

Short Form Specifications

Eagle Spec-GUARD™ Cafeteria Carving Station Food Guards, model _____. Carving station food shield designed to meet NSF requirements. Carving station allows the customer to view product as it is being prepared, plated, carved, or displayed.

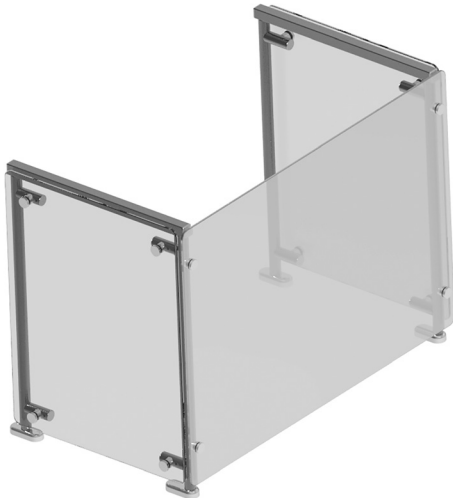

#DCS2-CA-NT

Item No.:	_____
Project No.:	_____
S.I.S. No.:	_____

Spec-GUARD™ Cafeteria Carving Station Food Guards

MODELS:

- DCS2-CA-NT
- DCS3-CA-NT
- DCS4-CA-NT
- DCS5-CA-NT
- DCS6-CA-NT

Design and Construction Features

- Fixed glass panels mounted on stainless steel standoffs
- 1" (25mm) stainless steel tubular frame
- Die-cast aluminum mounting plates with stainless steel covers
- 3/4" (19mm) radius on glass panels
- 3/8" (10mm)-thick top glass
- 1/4" (6mm)-thick front and side glass
- End glass included

Options / Accessories

- Heat lamps
- Lights
- 3 5/8" round mounting plate
- 3" Oval mounting plate
- 3" Oval offset mounting plate
- 2" x 8" rectangular mounting plate
- 3-point anchor
- Custom lengths available

⚠ WARNING:

This product can expose you to chemicals including Chromium, which is known to the state of California to cause cancer and birth defects or other reproductive harm. For more information, go to www.P65Warnings.ca.gov.

EAGLE GROUP

100 Industrial Boulevard, Clayton, DE 19938-8903 USA
 Phone: 302-653-3000 • 800-441-8440 • Fax: 302-653-2065
www.eaglegrp.com
www.eaglemhc.com

For custom configuration or fabrication needs, contact our **SpecFAB®** Division.
 Phone: 302-653-3000 • Fax: 302-653-2065 • e-mail: quotes@eaglegrp.com



EG33.27D Rev. 02/25

Spec sheets available for viewing, printing or downloading from our online literature library at our websites

Eagle Foodservice Equipment, Eagle MHC, and SpecFAB® are divisions of Eagle Group. ©2025 by the Eagle Group



Item No.: _____
 Project No.: _____
 S.I.S. No.: _____

Spec-GUARD™ Cafeteria Carving Station Food Guards

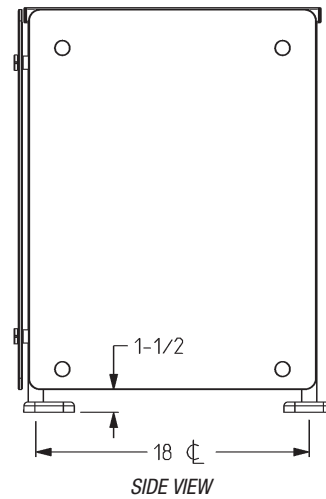
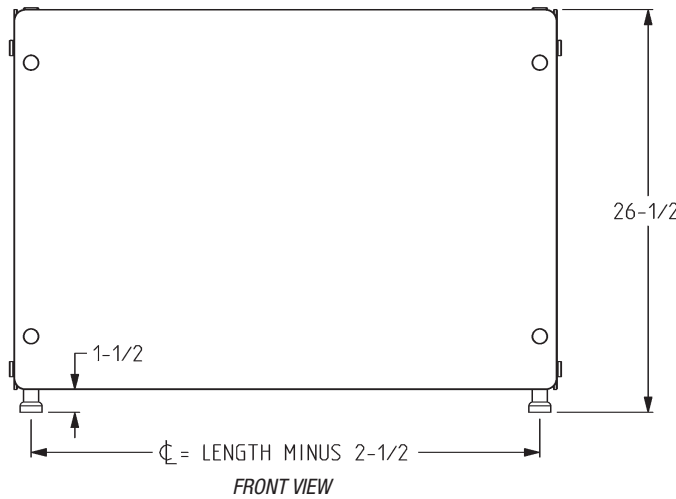
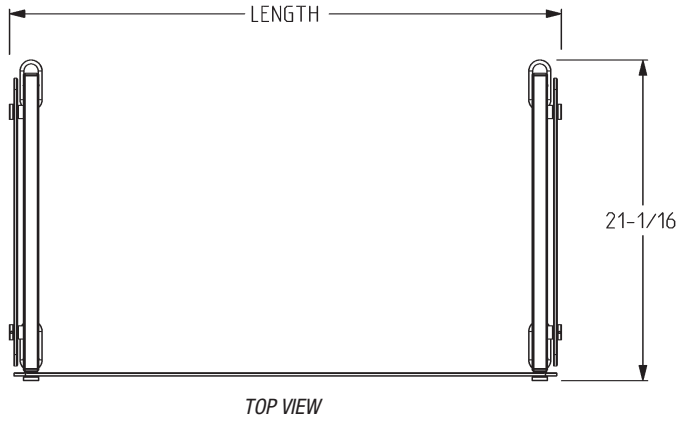

fits Series	length		weight		model #
	in.	mm	lbs.	kg	
DCS2	36"	914	287	130.2	DCS2-CA-NT
DCS3	50"	1270	310	140.6	DCS3-CA-NT
DCS4	64"	1626	339	153.8	DCS4-CA-NT
DCS5	78"	1981	362	164.2	DCS5-CA-NT
DCS6	96"	2438	391	177.4	DCS6-CA-NT

EAGLE GROUP
 100 Industrial Boulevard, Clayton, DE 19938-8903 USA
 Phone: 302-653-3000 or 800-441-8440 • Fax: 302-653-2065
 www.eaglegrp.com • www.eaglehmc.com

Printed in U.S.A.
 ©2025 by Eagle Group

Rev. 02/25

Spec sheets available for viewing, printing or downloading from our online literature library at our websites

Although every attempt has been made to ensure the accuracy of the information provided, we cannot be held responsible for typographical or printing errors. Information and specifications are subject to change without notice. Please confirm at time of order.