

#KBD-2/SS Keyboard Drawer for 24" & 30" Wire Shelves

ASSEMBLY INSTRUCTIONS

CAUTION

INSPECT CONTENTS IMMEDIATELY AND FILE CLAIM WITH DELIVERING CARRIER FOR ANY DAMAGE. **SAVE YOUR BOX AND ALL PACKING MATERIALS.** YOU ARE RESPONSIBLE FOR DAMAGE TO YOUR UNIT IF RETURNED IMPROPERLY PACKED.

Thank you for your purchase. Before assembly, read this instruction sheet carefully. After reading, be sure to store this instruction in a safe place, should it be needed for future reference.

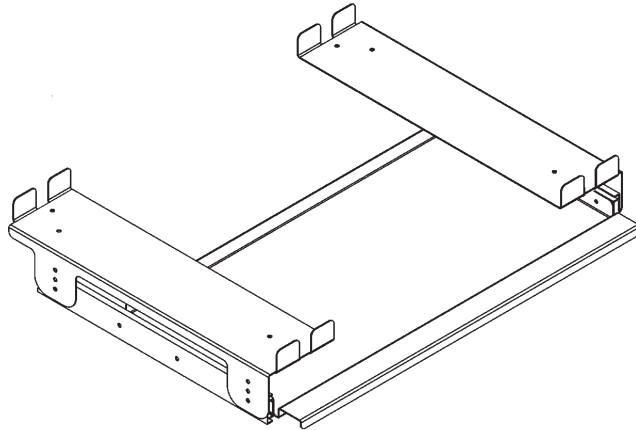

Parts List

#	qty	description
1	4	hooks
2	1	left-hand bracket
3	1	left-hand slide
4	1	right-hand bracket
5	1	right-hand slide
6	1	keyboard drawer
hardware (not shown)		
	8	screws
	8	washers
	8	hex nuts

(continued on back page)

#KBD-2/SS Keyboard Drawer for 24" & 30" Wire Shelves

ASSEMBLY INSTRUCTIONS

Before assembly...

- Note the front-to-back dimension (24" or 30") of your wire shelf.
- On the left and right brackets, note the locations of the holes to be used with the hooks in Step 2. See the illustration at right.

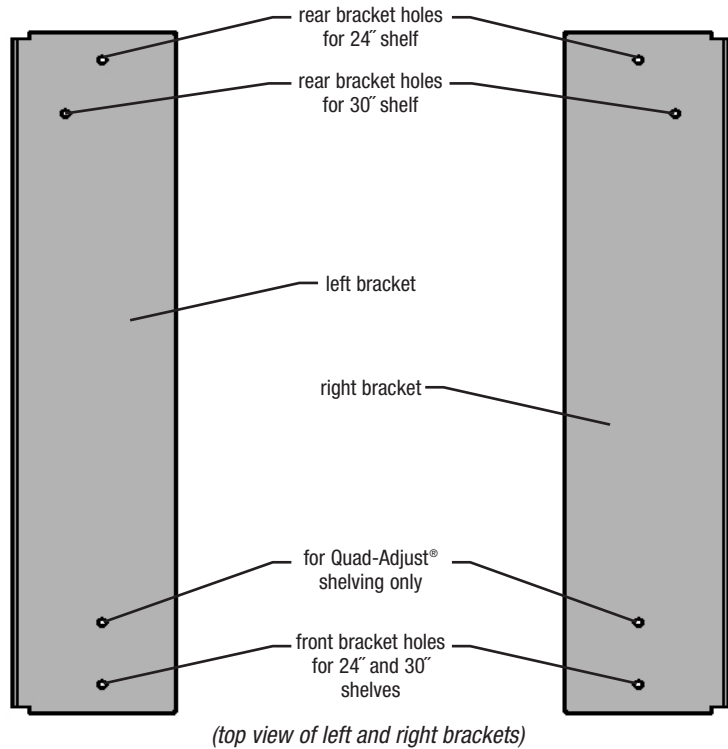

Step 1 - Determine location of brackets.

- Using the appropriate illustration below as a guide, please note the number of front-to-back mat wires that separate the hooks at the front and rear of the brackets.
- Please note the locations of the hooks in relation to the locations of the brackets.
- Place hooks onto 1st and 4th side-to-side mat wires of wire shelf, as shown.

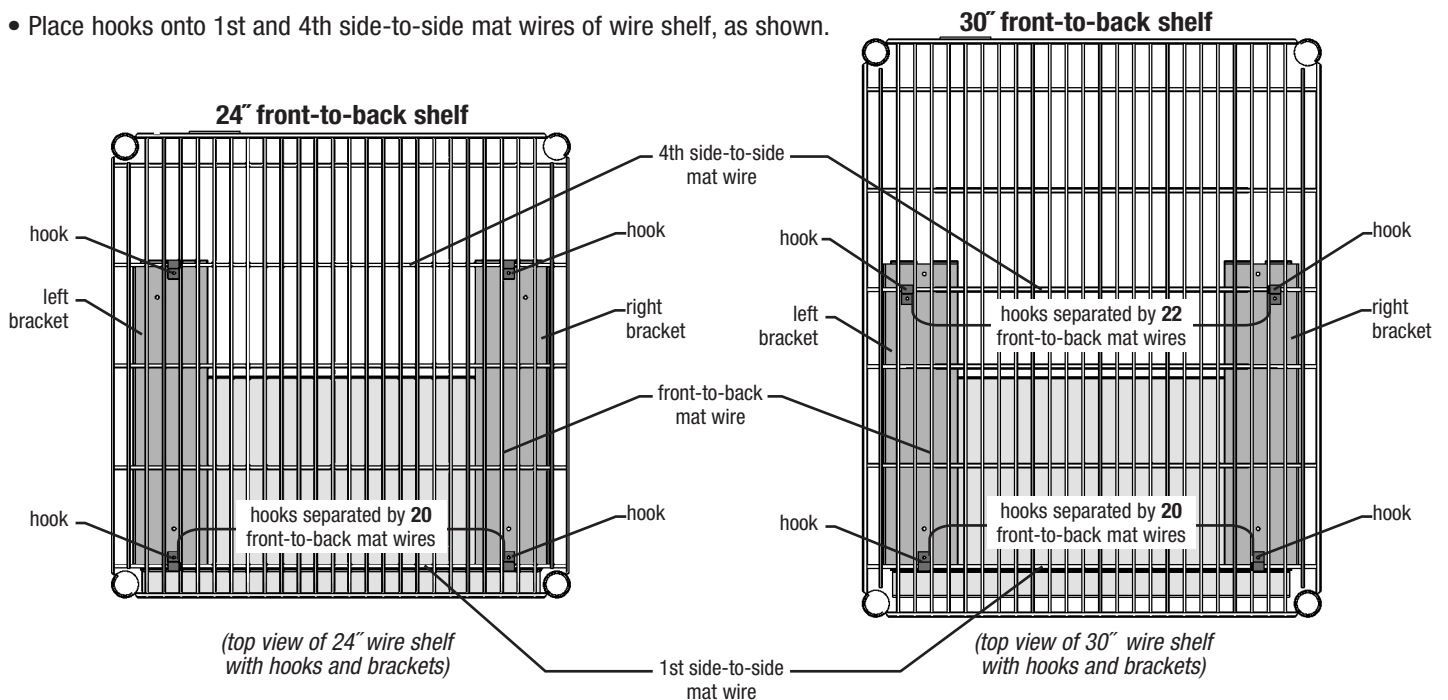

(continued on next page) →

#KBD-2/SS Keyboard Drawer for 24" & 30" Wire Shelves

ASSEMBLY INSTRUCTIONS

Please note:

For instructional purposes, this instruction sheet will show assembly of keyboard drawer to a 24" wire shelf.

Step 2 - Attach brackets to wire shelf.

- Position bracket up to the bottom of shelf, aligning holes in bracket with hole in each hook.
- Attach bracket to hooks with bolt, washer, and hex nut.
- Repeat with remaining bracket and hooks.

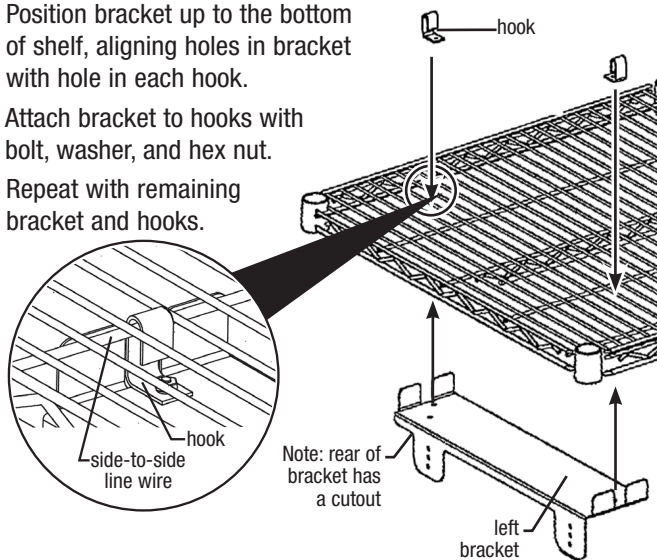

Step 3 - Detach outer component of each slide from keyboard drawer.

Extend each slide until outer slide components are detached from keyboard drawer.

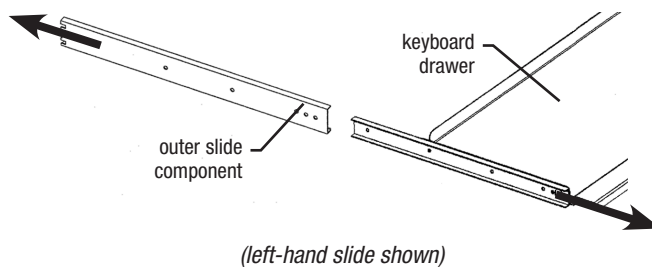

(continued on back page) 

#KBD-2/SS Keyboard Drawer for 24" & 30" Wire Shelves

ASSEMBLY INSTRUCTIONS

Step 4 - Attach outer slide components to brackets.

- Attach outer slide component to bracket with bolt, washer, and hex nut at the holes shown in illustration.
- Repeat with remaining outer slide component and bracket.

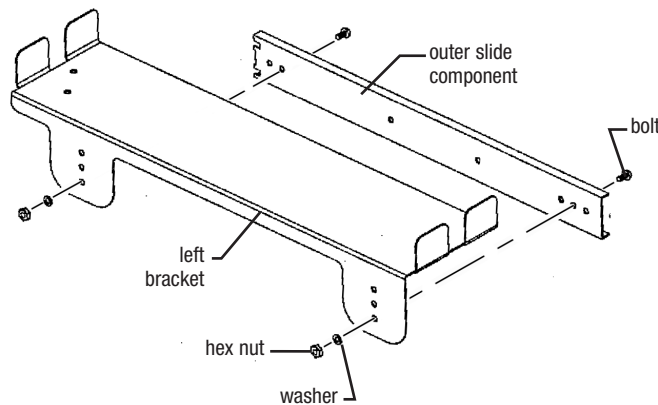

(Note: bracket shown without shelf for clarity of illustration)

Step 5 - Assemble keyboard drawer to outer slide components.

Align each side of drawer with both outer slide components, and push.

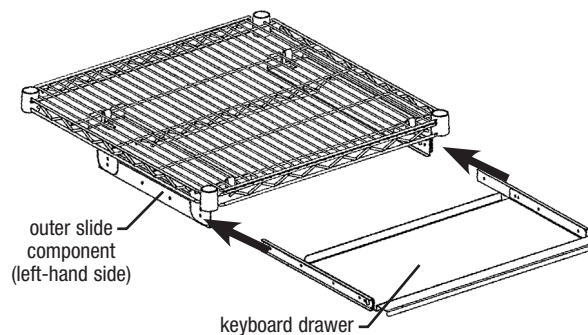

(End) Assembly is complete.



Profit from the Eagle Advantage®

• 100 Industrial Boulevard, Clayton, Delaware 19938-8903 U.S.A.
• Phone: 302/653-3000 • 800/441-8440 • Fax: 302/653-2065
• www.eaglegrp.com • www.eaglemh.com

Eagle Foodservice Equipment, Eagle MHC, and SpecFAB® are divisions of Eagle Group. ©2025 by the Eagle Group