

# K-12 DINING SOLUTIONS



Director's Choice<sup>®</sup> Modular Cafeteria Serving Units

*Addressing the Challenges in K-12 Schools*



**EAGLE**<sup>™</sup>  
Foodservice Equipment Division  
*Profit from the Eagle Advantage<sup>®</sup>*



# Director's<sup>®</sup> Choice - Applications

Eagle's Director's Choice<sup>®</sup> Modular Cafeteria Serving Units are 30" wide and available in three working heights - the standard 34" which complies with ADA guidelines for accessibility standards, 30" for middle schools, and low profile 28" for elementary schools. Each unit is fully mobile on standard 5" casters, two with brakes on server side. The frame and top are constructed of type 304 stainless steel. A patent pending docking device keeps adjoining units together without the use of tools. All units come with a standard front laminate panel - holly berry red (Wilsonart<sup>®</sup> D307-60) mounted on galvanized subpanel. Many options are available, including decorative laminate or stainless steel end panels and front panels, removable undershelves, rear doors and panels, tray slides, work shelves, and single tier or double tier glass sneeze guards. Custom accessories include decorative sneeze guards, decorative perimeter skirt and inboard casters.



Sturgis High School, Sturgis MI. Consultant: J. Riemenschneider & Associates



## Hot Food Units c us

### Director's Choice®

The Hot Food Unit is a necessity to any hot food buffet. 12" x 20" heat wells are fully insulated with individual thermostatic controls and hold 12" x 20" food pans. Unit available with 2-6 wells for wet or dry operations. Optional individual drain for each well with manifold to single valve available. Units come in several voltage/wattage options, 120V, 208V and 240V depending on length of cart chosen, wired to cord with plug. Additional options include 3-Phase operation and field wire provisions. NSF approved and UL listed.



Hot food unit shown with double tiered glass sneeze guard with florescent lamps, optional tray slide, and optional yellow laminate panels.



## Cold Food Units c us

### Director's Choice®

All mechanical Cold Food Units are 120V, wired to a 6' cord, and include 3/4" diameter drain with valve. The standard depth of a cold pan is 4<sup>5</sup>/<sub>8</sub>", and optional full depth pan 9<sup>3</sup>/<sub>4</sub>" deep with side coil is also available. NSF approved and UL listed, NSF-7 units available. NEMA 5-15P. Ice cooled pan units come with a 4<sup>5</sup>/<sub>8</sub>"-deep by 19<sup>7</sup>/<sub>8</sub>"-wide iced cold pan.

Cold food unit shown with optional double tiered glass sneeze guard with florescent lamps, optional tray slide, optional orange laminate panels, and server side shown with optional louvered doors.

## Hot/Cold Units c us

### Director's Choice®

Eagle's Hot/Cold Units are type 304 stainless steel construction. 16 gauge stainless steel 2"-tall top. Dual temperature hot or cold operation. Pre-wired with hot/cold selector switch, required thermostatic controls and pilot light. Welded 1<sup>1</sup>/<sub>2</sub>" square tubular stainless steel base. 5" poly tread swivel casters—two with brake. Predrilled to accommodate accessories.



Hot/Cold unit with optional tray slide and end panels

## Frost Top Units c us

### Director's Choice®

The Frost Top Unit features a 1" thick frost top made of 14/304 stainless steel with a full perimeter gutter to collect melted condensate. The refrigeration system is mounted to the bottom of the frost top and is fully charged with CFC-free refrigerant and is ready for immediate use. An optional removable bottom panel is available to fit open base construction. NSF approved and UL listed. NEMA 5-15P.



Frost top unit shown with standard front laminate and optional tray slide.

## Heated Surface Units



### Director's Choice®

The Heated Surface Unit features recessed aluminum top with blanket-type foil for uniform heat. Heated surface area is 19½" front-to-back, with available lengths ranging from 42" to 72". Includes control thermostat with a range of 80° to 200°F and ON/OFF switch. 120V operation wired to a cord with either a NEMA 5-15P plug or NEMA 5-20P, depending on unit length. Four lengths to choose from. NSF approved and UL listed.



Heated Surface unit shown with optional tray slide and optional yellow laminate panels.

## Solid Top Utility Carts



### Director's Choice®

The Solid Top Utility Cart provides a solid stainless steel work surface featuring hat channel reinforced top. Use this work surface for preparation or display of products along the serving line. Unit available in five lengths. A full range of options and accessories allow for infinite configurations for use within the foodservice facility. NSF approved.



Solid top unit shown with optional double tiered glass sneeze guard with fluorescent lamps, optional tray, slide, and optional orange laminate panels.

## Cashier Units



### Director's Choice®

The Cashier Cart is an integral piece in any serving line. The top surface is 30" x 24" or 30" x 36". Three configurations are available to suit your needs - inline, right end, or left end. Each unit comes with a standard keyed cash drawer with handle fitting flush in a stainless steel wrapper, and an integrated footrest welded to the frame for strength. NSF approved.



Cashier unit shown with optional tray slide and optional orange laminate panels, server side shown with removable undershelf.

## Tray and Silverware Unit



### Director's Choice®

The Tray and Silverware Unit include elevating dispenser and eight polyethylene silver cylinders. The tray capacity is 150 (14" x 18" and 15" x 20" trays).



Tray and Silverware Unit

## Corner Transition Units



### Director's Choice®

Four styles of Corner Transition Units are available to suit most configurations: outside corner, outside miter and inside corner and inside miter. Front panels are on customer side of unit. Some options are not available, consult factory for additional information.



Outside corner shown with optional tray slide and work shelf.

side view outside miter



outside miter shown with optional tray slide and workshelf

# Director's<sup>®</sup> Choice - Options

## Removable Undershelf

Stainless steel construction. Available to fit models of 36", 50", 64", 78", and 96" lengths.



## Rear Panels

Stainless steel construction. Available in solid or louvered. Panels offered as fixed or lift-off.

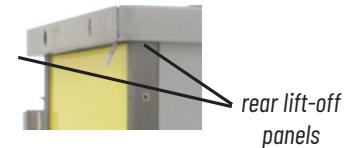

## Rear Doors

Stainless steel construction available in solid or louvered. Fits models of 24", 36", 50", 64", 78", and 96" lengths. Two models to choose from - hinged or sliding.

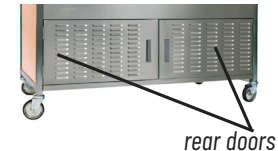

## Work Shelves

Stainless steel construction. 8" wide shelves and available in lengths of 36", 50", 64", 78", and 96" on drop-brackets. Offered in maple, stainless steel, polymer or Richlite<sup>®</sup>.

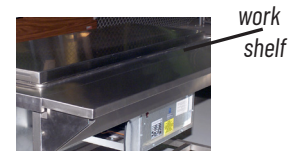

## Tray Slides

Stainless steel construction. Available in lengths of 30", 36", 50", 64", 78", and 96" for front, rear, or ends. Tray slides are 11½" wide on drop brackets.

**Available as:** Solid Ribbed, Tubular Three Rail Round or Square Tube

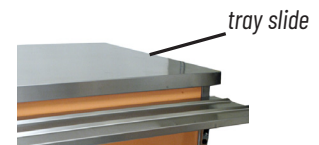

## Decorative Perimeter Skirt

Matches framework construction of Director's Choice<sup>®</sup> base. Serves as fixed skirt and kick plate. Available on front, ends or all sides. Choose from standard black laminate inlay, stainless steel, or laminate to match decor.

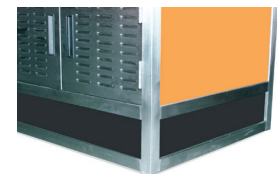

## Inboard Casters

Features heavy duty plate casters secured to 12 gauge stainless steel mounting brackets. Works with standard removable undershelfing. Eliminates potential caster swivel interference to adjacent equipment. Required for decorative perimeter skirt option.



## Eagle's line is fully customizable:

- Interconnected Wiring
- Cutting Boards
- Decorative Laminates
- Stainless Steel Panels
- Varied Working Heights of Units
- Fluorescent Lamps
- Receptacles and Remote Switches
- Sneeze Guards with Single Heat Lamp
- Varied Heights of Tray Slides

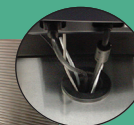

# Spec-SHIELD™

## Spec-SHIELD™

Eagle's Spec-SHIELD™ is an innovative, fully-adjustable sneeze guard /counter protector system. Glass is held in place with patented-design casting that allows for ease of glass adjustment as well as easy removal for cleaning. Angle of front glass adjusts in 18° increments, allowing for acceptance by local health codes as well as meeting NSF requirements.

### Spec-SHIELD™ Self-Service Food Guards

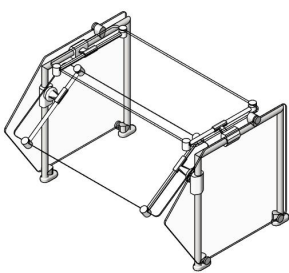

Single-Tier Units

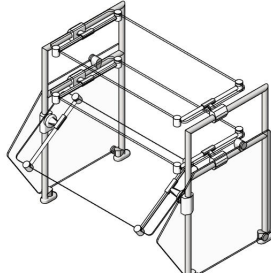

Double-Tier Units

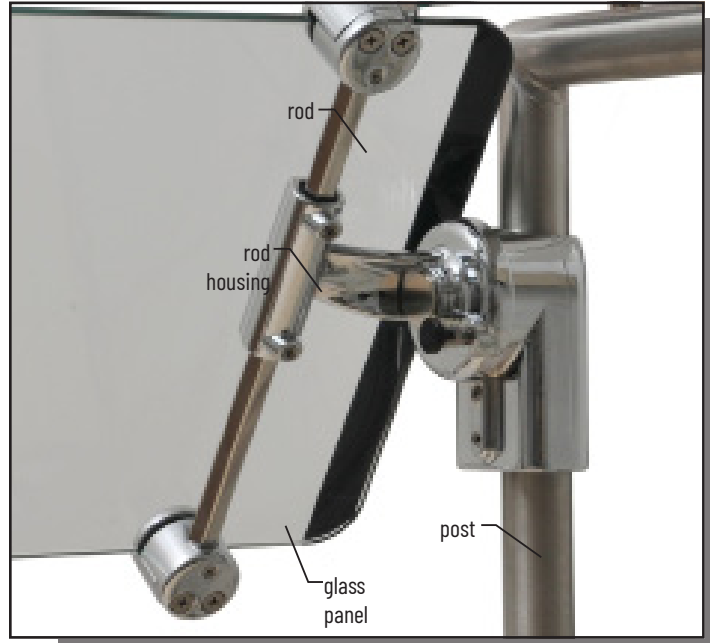

### Spec-SHIELD™ Self-Service Buffet Food Guards

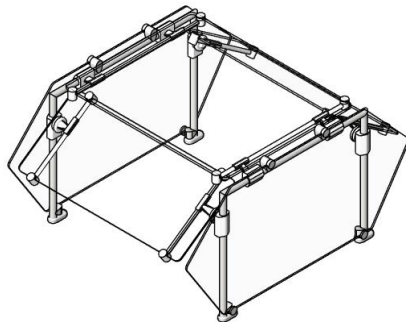

Single-Tier Units

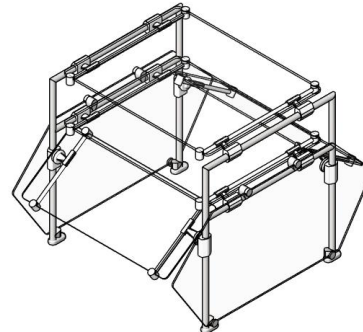

Double-Tier Units

### Spec-SHIELD™ Cafeteria Food Guards

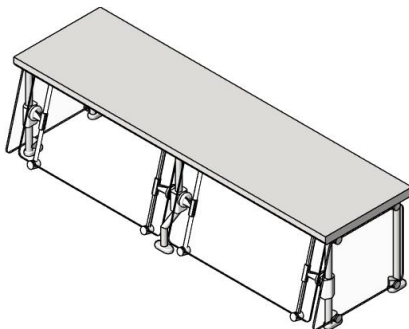

With Solid Top

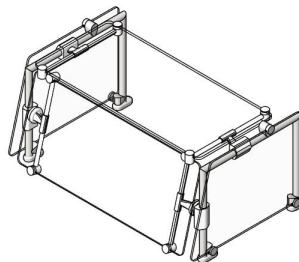

With Glass Top

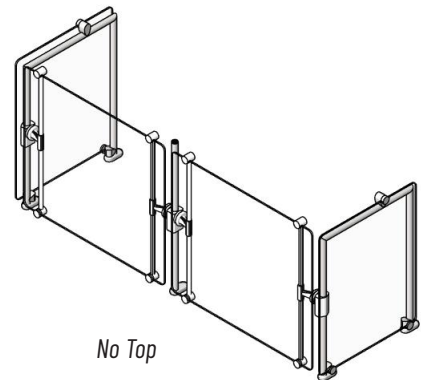

No Top

For custom configuration or fabrication needs, contact our **SpecFAB® Division**.

P: 302-653-3000 • F: 302-653-2065 • e-mail: quotes@eaglegrp.com

**UNIQUE PATENTED  
DESIGN - 3 PATENTS**

Patent Nos. 9,538,868; 9,516,958;  
9,339,131; 9,326,621; 9,723,935

# Sneeze Guards

## Sneeze Guards

Features stainless steel top panel with polycarbonate sneeze guards. Available in lengths of 36", 50", 64", 78", and 96". Sneeze guards must be ordered at the same time as unit - factory installation of sneeze guards is required.



Single-Tier Sneeze Guards

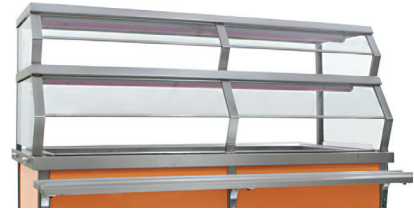

Double-Tier Sneeze Guards

## Decorative Deluxe Sneeze Guards

Designed per NSF Standard 2. Frame finish available in stainless steel, or choose from Eagle's Stand-Outs™ custom epoxy color selection. Polycarbonate front panel and end guards. Edges trimmed with a metal channel. Optional tempered glass (meets ANZI 97.1) available.



Cafeteria Style Single-Tier Sneeze Guard

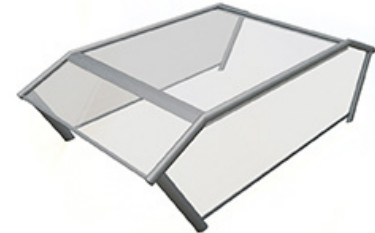

Buffet Style Single-Tier Sneeze Guard

## Heat Lamps

Attaches to underside of sneeze guard (or to underside of bottom sneeze guard on double-tier units). Wired to cord and plug, exit base of unit.



## REDHOTS® Display Lights

Wired to cord and plug, exit base of unit. Must be factory installed.

# Customize IT

## DIRECTOR'S CHOICE®

Custom Signage and Decal Service

Autodesk® Building Design Suite Premium

Eagle can use Revit® software to provide a rendered proof for final approval before production.

Contact us:  
revit@eaglegrp.com | 800-441-8440



# Equipment that Makes a Statement

## • LASER-CUTTING & ETCHING

- Offers a "high-tech" look
- Creates smooth curves along text/artwork

## • DECALS

- Industrial strength
- Factory installed
- Vinyl with adhesive backing

## • MAGNETIC SIGNS

- Customized magnetic signage option can be swapped out easily to change up messaging and designs as desire based on menu changes, seasonality or special school events

## CONTACT US FOR A QUOTE

FAX: 302-653-2065

E-MAIL: [quotes@eaglegrp.com](mailto:quotes@eaglegrp.com)

## EAGLE OFFERS PERSONALIZED BRANDING!

Eagle offers personalized branding of graphic designs as an option on portable bars, Director's Choice® cafeteria serving units and SpecFAB® custom counters.

Select from stainless steel, various plastics, laminates, solid surface man-made and naturally occurring materials, woods, magnetic sheets and designer aluminum. We provide a 3D rendering of your logo or design prior to production.

Here's an idea, **LIGHT IT UP!**

Laser etched cast acrylic or multi layer acrylic effects. Lighting options include low voltage LED in single or variable colors. Stainless steel or millwork trim completes the custom look.



*Right down the line, Director's Choice® Modular Cafeteria serving units work for you at every stop. From hot food units to frost top units, we have it covered, with numerous options and custom accessories, they are not only functional but stylish.*



**The Eagle Advantage** begins right here in our state of the art manufacturing facility - with 14 acres under one roof, where the most comprehensive broadline product offering in the industry takes shape. This all-inclusive design and production capability offers distinct advantages to our customers. Streamlined ordering and shipping substantially reduce freight, receiving, installation and administrative costs.

Supporting it all is a framework of highly responsive customer service

representatives, the most innovative, versatile and durable equipment available on the market today, a fleet of company-owned trucks, plus amply stocked distribution centers in strategic locations nationwide - which guarantees product availability and delivery.

Together, it adds up to product excellence enhanced by measurable cost savings and value. We call it The Eagle Advantage and you can profit from it.



Profit from the Eagle Advantage®

[www.eaglegrp.com](http://www.eaglegrp.com)

### Foodservice Division:

Phone: (800) 441-8440 • FAX: (302) 653-2065

### Corporate Headquarters:

100 Industrial Boulevard • Clayton, DE

19938-8903 USA • Phone: (302) 653-3000