



Profit from the Eagle Advantage®

Phone: (800) 441-8440 • (302) 653-3000

FAX: (302) 653-2065

# Product Announcement

## Short Form Specifications

Eagle Group Stationary Staging Shelving, model \_\_\_\_\_. Knockdown unit contains five patented QuadTruss® wire shelves with clear inlays, two 63" posts, two 54" posts, five clear shelf markers and sign. Available in chrome or black epoxy finish.

Item #:	_____
Model #:	_____
Project #:	_____
SIS #:	_____

EG8216 Rev. 11/24



## Mobile Pick-Up / Stationary Staging Shelving

### Design & Construction Features:

- Modular shelving system adjustable on 1" increments
- Five (5) wire shelves with patented QuadTruss® design (patent #5,390,803)
- Five (5) clear shelf inlays
- Five (5) clear shelf markers
- Two (2) 63" front posts
- Two (5) 54" rear posts
- All posts are 1" diameter
- Mobile order signage
- Chrome or black epoxy finish

### Options / Accessories:

- Dividers
- Enclosure panels
- Additional shelf markers
- Other finishes



The new Mobile Pick-Up / Stationary Staging Shelving from Eagle is designed with streamlined curbside pick-up in mind. These units feature five (5) 18"-wide shelves, posts, and "Mobile Order Pick Up" signage. Patented QuadTruss® (patent #5,390,803) wire shelves feature clear shelf inlays to prevent carry-out bags and/or containers from snagging as well as smaller items from falling through. Each shelf includes a shelf marker for labeling contents. Optional dividers, enclosure panels, and additional shelf markers available for further organization and efficiency.

For custom configuration or fabrication needs, contact our **SpecFAB® Division**.

Phone: (302) 653-3000. FAX: (302) 653-2065.

E-mail: quotes@eaglegrp.com





Profit from the Eagle Advantage®

# Mobile Pick-Up / Stationary Staging Shelving

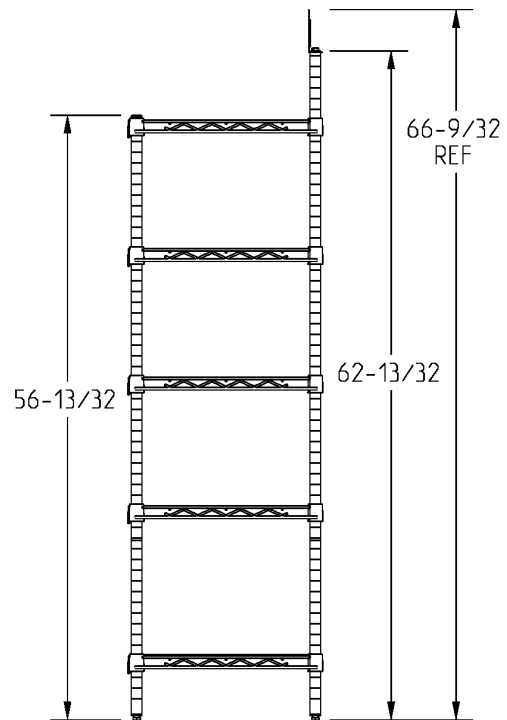
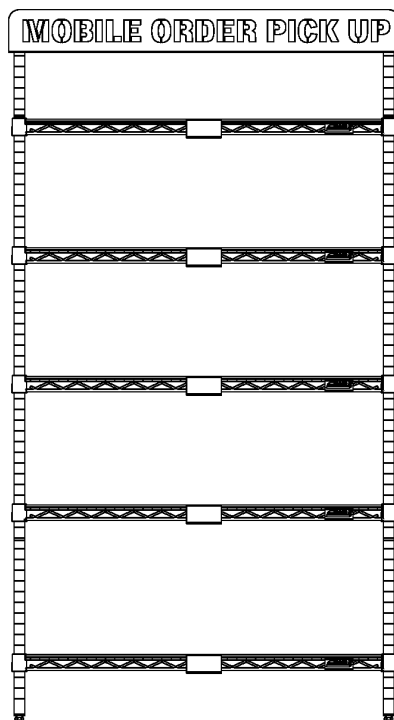
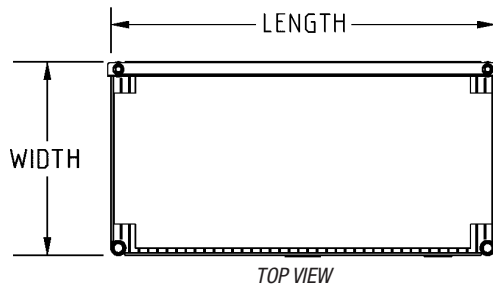

width		length		weight		Chrome	Black
in.	mm	in.	mm	lbs.	kg	model #	model #
18"	457	24"	608	65	29.5	TGS1824C-5	TGS1824BL-5
18"	457	36"	914	72	32.6	TGS1836C-5	TGS1836BL-5
18"	457	48"	1219	95	43.1	TGS1848C-5	TGS1848BL-5

Printed in U.S.A.

©2024 by Eagle Group

EG8222 Rev. 11/24

Phone: (800) 441-8440 or (302) 653-3000 • Fax: (302) 653-2065 • [www.eaglegrp.com](http://www.eaglegrp.com) • [www.eaglehmc.com](http://www.eaglehmc.com)

Although every attempt has been made to ensure the accuracy of the information provided, we cannot be held responsible for typographical or printing errors. Information and specifications are subject to change without notice. Please confirm at time of order.