



Profit from the Eagle Advantage®

Phone: (800) 441-8440 • (302) 653-3000

FAX: (302) 653-2065

Product Announcement

Short Form Specifications

Eagle Flush Floor Mop Sinks, model _____. Heavy gauge 304 stainless steel all-welded construction. Drain pan has built-in pitch towards drain, accommodates up to a 4"-diameter pipe, and comes with stainless steel removable perforated basket. 16.5" backsplash, plus splash at left, right, or both ends. Comes with either fiberglass or stainless steel grating.

Item #:	_____
Model #:	_____
Project #:	_____
SIS #:	_____

EG8227 Rev. 10/24

Design and Construction Features

- Heavy gauge type 304 stainless steel construction
- 16½"-high standard backsplash, with end splash on left, right, or both sides
- Available with subway-style fiberglass or stainless steel grates
- Anti-splash angles at front and rear of mop sink help eliminate spillage.
- Built-in pitch towards drain insures complete drainage
- Flow rate of 20 gallons per minute
- Stainless steel drain accommodates up to 4"- diameter pipe, and features removable perforated stainless steel basket.

For custom configuration or fabrication needs, contact our **SpecFAB® Division**.
 Phone: (302) 653-3000. FAX: (302) 653-2065.
 E-mail: quotes@eaglegrp.com

New Flush Floor Mop Sinks



unit with left and right splashes (with fiberglass grating)



unit with left splash (with fiberglass grating)



unit with right splash (with stainless steel grating)

Eagle's NEW Flush Floor Mop Sinks allow ease of disposing dirty water without lifting or spilling. 16½"-high standard backsplash, plus end splash(es), help protect adjacent walls and floors. Subway-style grating, for ease of cleaning and drainage, included.

Fiberglass grating features 1"-high yellow polyester material with non-slip grit top surface. Tapered "I" beam construction.

Type 304 stainless steel grating features 3/16" x 1" vertically positioned bars spaced 5/8" apart. 3/8" stainless steel rods, set 2/4" in from each edge, are welded to the bars to eliminate swaying.



Flush Floor Mop Sinks

Units with Left End Splash

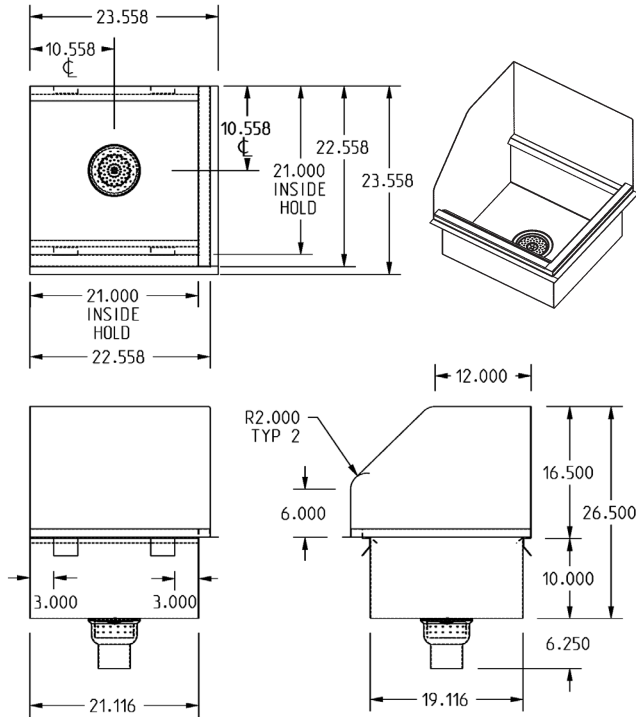

Units with Right End Splash

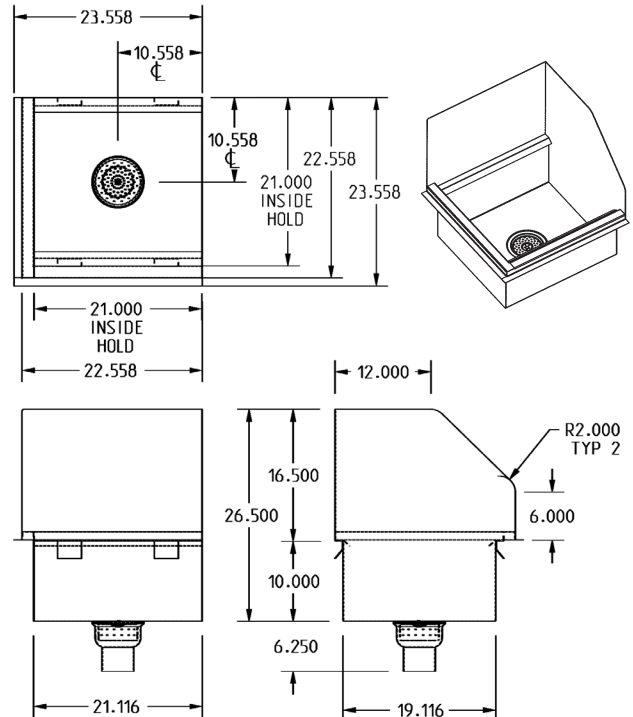

Units with Left & Right End Splashes

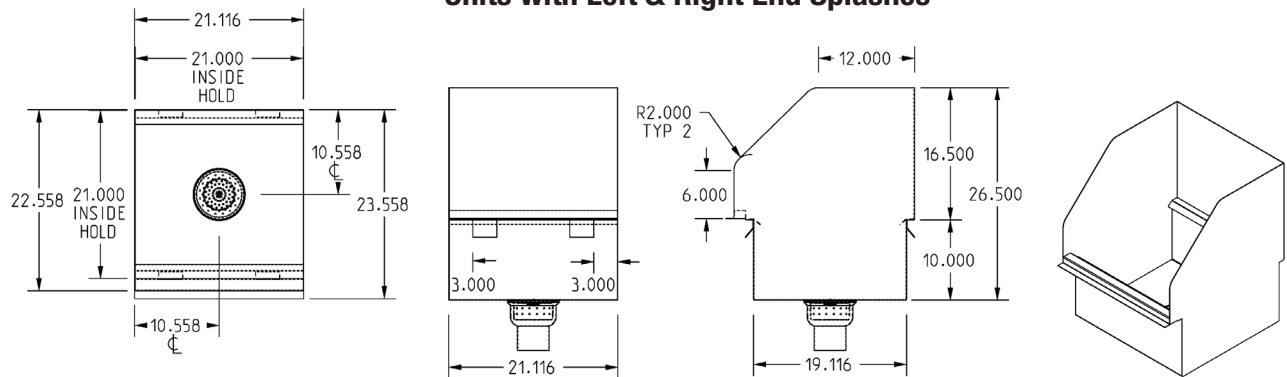

location of splash(es)	OVERALL DIMENSIONS width x length x height		BOWL DIMENSIONS width x length x height		BOWL CAPACITY gallons	FLOW RATE GPM	weight lbs. kg	WITH FIBERGLASS GRATING	WITH STAINLESS STEEL GRATING
	inches	mm	inches	mm				model #	model #
left side	23 ⁵ / ₈ " x 23 ⁵ / ₈ " x 32 ³ / ₄ "	600 x 600 x 832	19" x 21" x 10"	483 x 533 x 254	17.1	20	65 29.5	FF2119-FG-LS	FF2119-SG-LS
right side	23 ⁵ / ₈ " x 23 ⁵ / ₈ " x 32 ³ / ₄ "	600 x 600 x 832	19" x 21" x 10"	483 x 533 x 254	17.1	20	65 29.5	FF2119-FG-RS	FF2119-SG-RS
both sides	23 ⁵ / ₈ " x 21 ¹ / ₈ " x 32 ³ / ₄ "	600 x 537 x 832	19" x 21" x 10"	483 x 533 x 254	17.1	20	65 29.5	FF2119-FG-LRS	FF2119-SG-LRS