



Profit from the Eagle Advantage®

# Specification Sheet

## Short Form Specifications

Eagle Group SPEC-BAR® Portable Bar with Workboard, model #\_\_\_\_\_. Welded 1-1/2" type 300 stainless steel square tubular base construction. 80" length, 33" wide, 48" high with 34" work height. Fully mobile - standard 4" poly tread casters with brake. Ice bin is 15" x 19" x 8", with 1-1/2" drain. Workboard is 48" with 1-1/2" drain. Speed rail is full length. Storage for four (4) 20" x 20" x 4" glass racks. Ice chest and workboard plumbed independently.



#SBPB-CWS-6



available with lift-up countertops

## Options / Accessories

- Solid surface bar top
- Laminate or powder coated panels

## EAGLE GROUP

100 Industrial Boulevard, Clayton, DE 19938-8903 USA  
 Phone: 302-653-3000 • 800-441-8440 • Fax: 302-653-2065  
[www.eaglegrp.com](http://www.eaglegrp.com)  
[www.eaglemhc.com](http://www.eaglemhc.com)

For custom configuration or fabrication needs, contact our **SpecFAB®** Division.  
 Phone: 302-653-3000 • Fax: 302-653-2065 • e-mail: [quotes@eaglegrp.com](mailto:quotes@eaglegrp.com)

Item No.:	_____
Project No.:	_____
S.I.S. No.:	_____

# SPEC-BAR® Portable Bars with Workboard

## MODELS:

- SBPB-CWS-6
- SBPB-CWS-6-XCT

## Design and Constructions Features

- Welded 1 1/2" (38mm) type 300 stainless steel square tubular base construction
- Stainless countertop with marine edge
- 4" (102mm) casters with brake
- 15" x 19" x 8" (381 x 483 x 203mm) ice chest with 1 1/2" (38mm) drain
- 48" (1529mm) workboard with top embossments and 1 1/2" (38mm) drain
- Full length double speed rail
- Storage for four 20" x 20" x 4" (508 x 508 x 102mm) glass racks
- Available with or without lift-up stainless steel countertops.





Item No.: \_\_\_\_\_  
 Project No.: \_\_\_\_\_  
 S.I.S. No.: \_\_\_\_\_

# SPEC-BAR® Portable Bars with Workboard

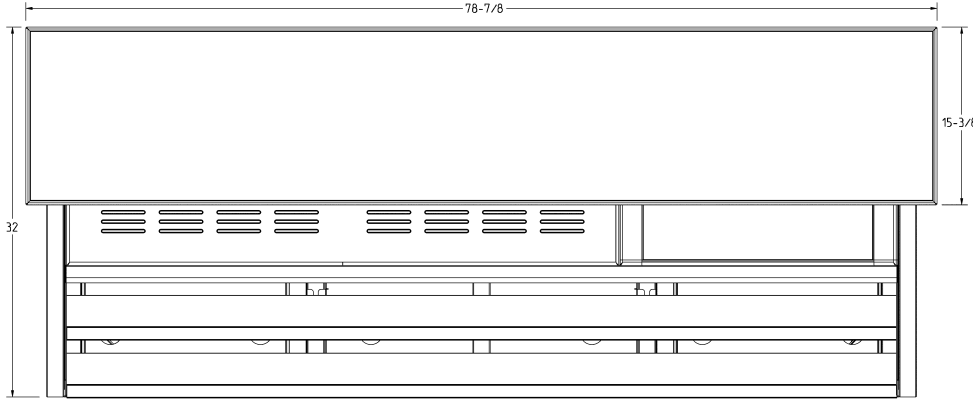

TOP VIEW

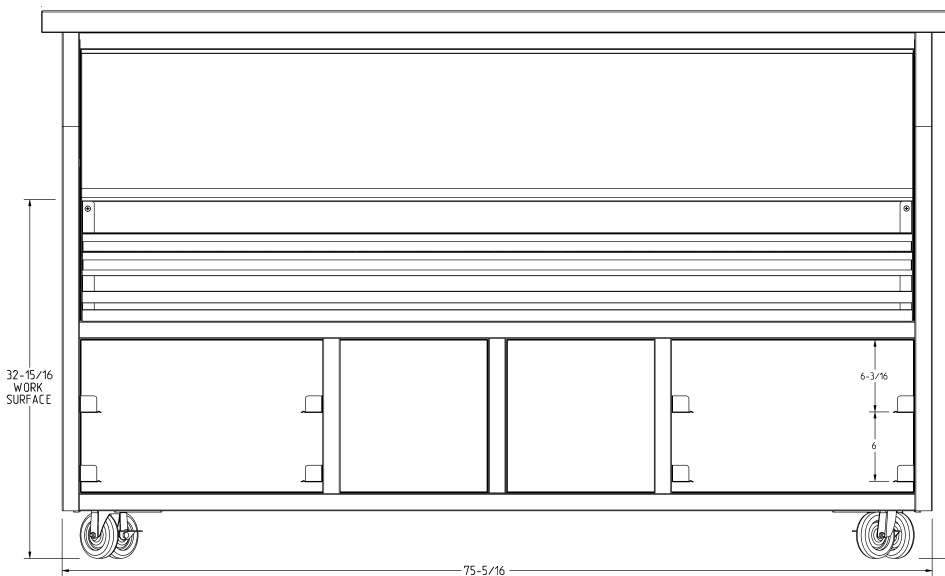

FRONT VIEW (WORKER'S SIDE)

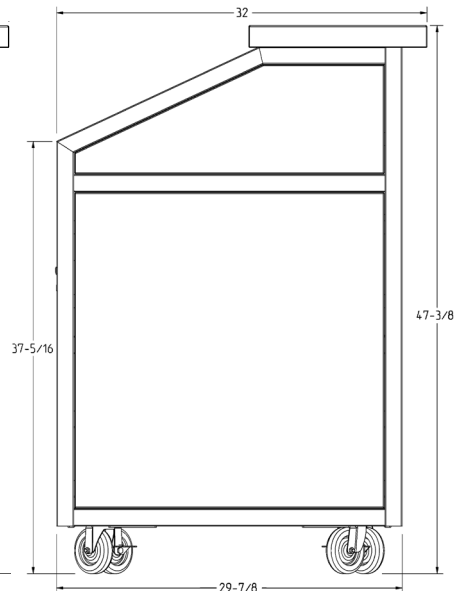

SIDE VIEW

O.A. size *				working height		Unit without Lift-Up Countertops	Unit with * Lift-Up Countertops
(length x width x height)						model #	model #
in.	mm	in.	mm				
80" x 32" x 48"	2032 x 818 x 1219	34"	864			<b>SBPB-CWS-6</b>	<b>SBPB-CWS-6-XCT</b>

\* Overall ("O.A.") length of model #SBPB-CWS-6-XCT is with lift-up countertops folded down. With both lift-up countertops extended, O.A. length is 130" (3302mm).

**EAGLE GROUP**  
 100 Industrial Boulevard, Clayton, DE 19938-8903 USA  
 Phone: 302-653-3000 or 800-441-8440 • Fax: 302-653-2065  
 www.eaglegrp.com • www.eaglehmc.com

Printed in U.S.A.  
 ©2024 by Eagle Group

Rev. 10/24

Spec sheets available for viewing, printing or downloading from our online literature library at our websites

Although every attempt has been made to ensure the accuracy of the information provided, we cannot be held responsible for typographical or printing errors. Information and specifications are subject to change without notice. Please confirm at time of order.