



Profit from the Eagle Advantage®

Specification Sheet

Short Form Specifications

Eagle Group SPEC-BAR® Portable Bar, model# _____.
Welded 1-1/2" type 300 stainless steel square tubular base construction. 80" length, 33" wide, 48" high with 34" work height. Fully mobile - standard 4" poly tread casters with brake. 12"-wide five-step liquor display with stainless and ABS construction with snap-on label cover. 12"-wide blender station with sink, workboard, wet waste drain, and blender shelf. 48" combination ice chest with separate insulated bottle and ice bin, double speed rail, and sliding cover. Storage for four (4) 20" x 20" x 4" glass racks. Bottle bin, ice bin, and workboard plumbed independently.



unit with lift-up stainless steel countertops and optional solid surface bar top

Options / Accessories

- Solid surface bar top
- Laminate or powder coated panels

EAGLE GROUP

100 Industrial Boulevard, Clayton, DE 19938-8903 USA
Phone: 302-653-3000 • 800-441-8440 • Fax: 302-653-2065
www.eaglegrp.com
www.eaglehmc.com

For custom configuration or fabrication needs, contact our SpecFAB® Division.
Phone: 302-653-3000 • Fax: 302-653-2065 • e-mail: quotes@eaglegrp.com

Item No.:	_____
Project No.:	_____
S.I.S. No.:	_____

SPEC-BAR® Portable Bars

MODELS:

- SBPB-CCS-6
- SBPB-CCS-6-XCT

Design and Constructions Features

- Welded 1 1/2" type 300 stainless steel square tubular base construction
- Stainless countertop with marine edge
- 4" casters with brake
- 5-shelf, 12" wide liquor display
- 12" blender station with workboard and blender shelf
- Ice bin with six-compartment bottle rack
- 15" x 35" x 10" ice bin with sliding cover
- 48" double speed rail
- Storage for four 20" x 20" x 4" glass racks
- Available with or without lift-up stainless steel countertops.





Item No.: _____
 Project No.: _____
 S.I.S. No.: _____

SPEC-BAR® Portable Bars

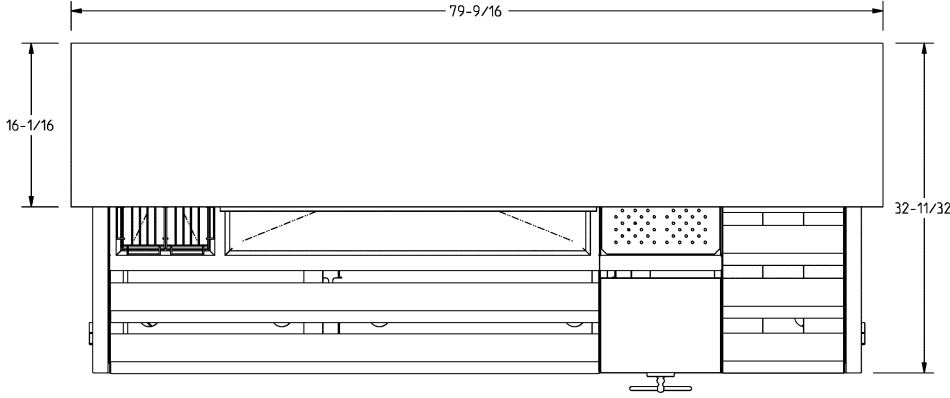

TOP VIEW

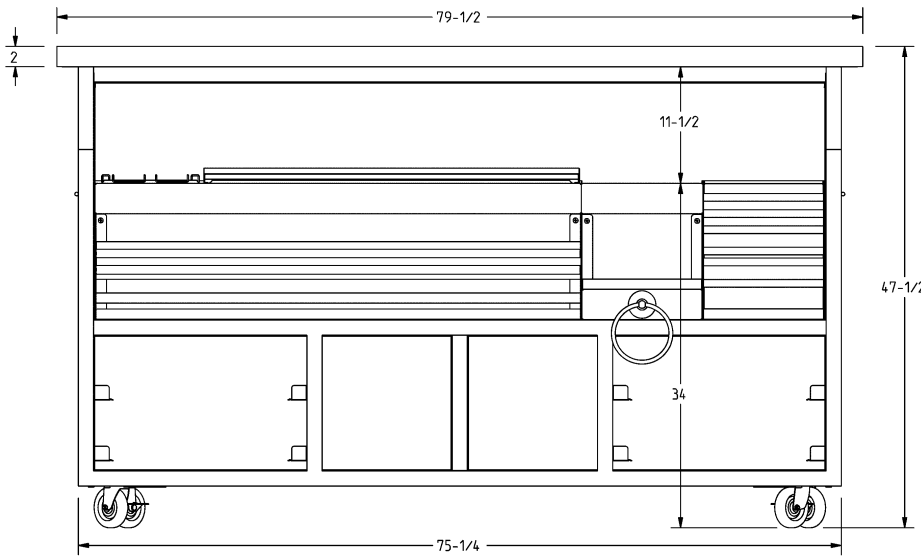

FRONT VIEW (WORKER'S SIDE)

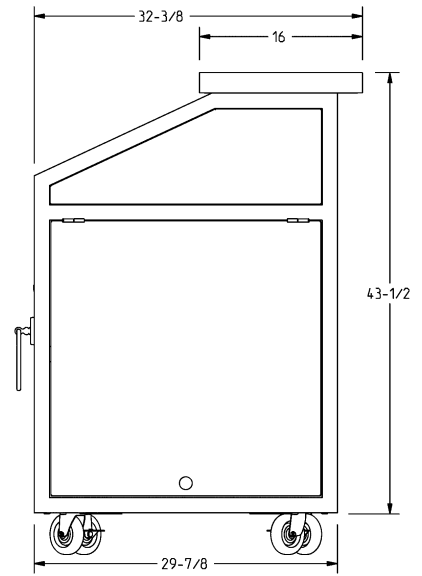

SIDE VIEW

O.A. size *		working height		Unit without Lift-Up Countertops	Unit with * Lift-Up Countertops		
length	width x height	in.	mm	model #	model #		
80"	33" x 48"	2032	838 x 1219	34"	864	SBPB-CCS-6	SBPB-CCS-6-XCT

* Overall ("O.A.") length of model #SBPB-CCS-6-XCT is with lift-up countertops folded down. With both lift-up countertops extended, O.A. length is 130" (3302mm).

EAGLE GROUP
 100 Industrial Boulevard, Clayton, DE 19938-8903 USA
 Phone: 302-653-3000 or 800-441-8440 • Fax: 302-653-2065
 www.eaglegrp.com • www.eaglehmc.com

Printed in U.S.A.
 ©2024 by Eagle Group

Rev. 10/24

Spec sheets available for viewing, printing or downloading from our online literature library at our websites

Although every attempt has been made to ensure the accuracy of the information provided, we cannot be held responsible for typographical or printing errors. Information and specifications are subject to change without notice. Please confirm at time of order.