



Profit from the Eagle Advantage®

Specification Sheet

Short Form Specifications

Eagle Group Spec-SHIELD™ Portable Food Shield, model #_____. Features 15" polycarbonate front panel mounted on 1" diameter stainless steel post with patented Spec-SHIELD™ system. 2"-wide stainless flat bar base with reversible mounting.

PATENTED
Patent Nos. 9,538,868; 9,516,958;
9,339,131; 9,326,621; 9,723,935



Item No.: _____
Project No.: _____
S.I.S. No.: _____

Portable Spec-SHIELD™ Protective Systems

MODELS:

- SPSH-PFS-SS-24
- SPSH-PFS-SS-30
- SPSH-PFS-SS-36
- SPSH-PFS-SS-42
- SPSH-PFS-SS-48
- SPSH-PFS-SS-54
- SPSH-PFS-SS-60
- SPSH-PFS-SS-66
- SPSH-PFS-SS-72

Design and Construction Features

- Spec-SHIELD™ patented adjustability
- 15" (381mm) polycarbonate panel
- 1" (25mm)-diameter stainless steel posts
- 2" (51mm) stainless steel flat bar base
- Reversible mounting

Options / Accessories

- 18" end panels*

* End panels are required for NSF compliance unless the end of the unit is within 3" of the building structure.

EAGLE GROUP

100 Industrial Boulevard, Clayton, DE 19938-8903 USA
Phone: 302-653-3000 • 800-441-8440 • Fax: 302-653-2065
www.eaglegrp.com
www.eaglemh.com

For custom configuration or fabrication needs, contact our SpecFAB® Division.
Phone: 302-653-3000 • Fax: 302-653-2065 • e-mail: quotes@eaglegrp.com

Certifications / Approvals



AutoQuotes



EG33.24F Rev. 10/24

Spec sheets available for viewing, printing or downloading from our online literature library at our websites



Item No.: _____
 Project No.: _____
 S.I.S. No.: _____

Portable Spec-SHIELD™ Protective Systems

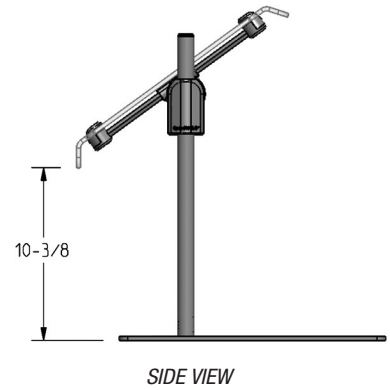
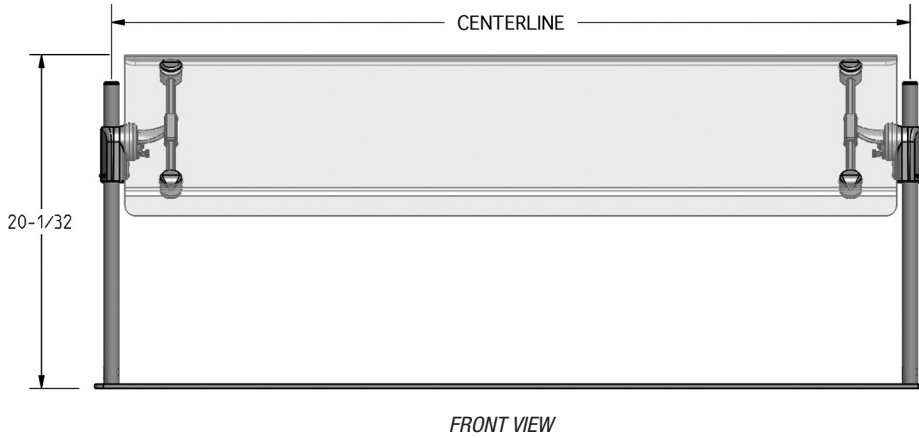
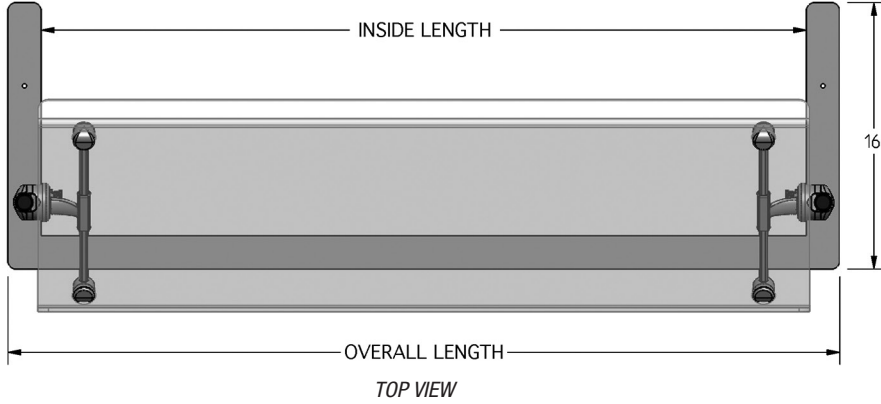

O.A. length*		inside length		centerline		weight		model #
in.	mm	in.	mm	in.	mm	lbs.	kg	
26"	660	22"	559	24"	610	30	13.6	SPSH-PFS-SS-24
32"	813	28"	660	30"	762	32	14.5	SPSH-PFS-SS-30
38"	965	34"	864	36"	914	34	15.4	SPSH-PFS-SS-36
44"	1118	40"	1016	42"	1067	36	16.3	SPSH-PFS-SS-42
50"	1270	46"	1168	48"	1219	38	17.2	SPSH-PFS-SS-48
56"	1422	52"	1321	54"	1372	40	18.1	SPSH-PFS-SS-54
62"	1575	58"	1473	60"	1524	42	19.2	SPSH-PFS-SS-60
68"	1727	64"	1626	66"	1676	44	20.0	SPSH-PFS-SS-66
74"	1880	70"	1778	72"	1829	46	20.9	SPSH-PFS-SS-72

* End glass adds 1/2" to overall dimension.

⚠ WARNING: This product can expose you to chemicals including Chromium, which is known to the state of California to cause cancer and birth defects or other reproductive harm. For more information, go to www.P65Warnings.ca.gov.

EAGLE GROUP
 100 Industrial Boulevard, Clayton, DE 19938-8903 USA
 Phone: 302-653-3000 or 800-441-8440 • Fax: 302-653-2065
www.eaglegrp.com • www.eaglehmc.com

Printed in U.S.A.
 ©2024 by Eagle Group

Rev. 10/24

Spec sheets available for viewing, printing or downloading from our online literature library at our websites

Although every attempt has been made to ensure the accuracy of the information provided, we cannot be held responsible for typographical or printing errors. Information and specifications are subject to change without notice. Please confirm at time of order.