



Profit from the Eagle Advantage®

Specification Sheet

Short Form Specifications

Eagle Touch-Free Portable Hand Sink, model _____.
Heavy gauge stainless steel cabinet with double pan hinged stainless steel door and lock. Furnished with 14" x 10" x 5"-deep stainless steel sink bowl, deck mount electronic-eye faucet, splash-mount electronic soap dispenser, electronic paper towel dispenser, 6"-diameter trash chute, 115-volt pump, 5-gallon fresh water tank, and 7-gallon waste water tank, GFCI electrical outlet, 10' cord/plug with cord wrap.



Options / Accessories

- Perimeter bumper
- Laminate
- Graphics

EAGLE GROUP

100 Industrial Boulevard, Clayton, DE 19938-8903 USA
 Phone: 302-653-3000 • 800-441-8440 • Fax: 302-653-2065
www.eaglegrp.com
www.eaglehmc.com

For custom configuration or fabrication needs, contact our **SpecFAB®** Division.
 Phone: 302-653-3000 • Fax: 302-653-2065 • e-mail: quotes@eaglegrp.com

Item No.:	_____
Project No.:	_____
S.I.S. No.:	_____

Touch-Free Portable Hand Sinks

MODELS:

- PHS-S-C-TF
- PHS-S-H-TF

Design and Constructions Features

- Unit with water heater provides tempered water. Unit without water heater provides ambient temperature water.
- Stainless steel cabinet body with locking door
- Deck mount electronic-eye gooseneck faucet with tempering valve
- Touch-free splash-mount paper towel dispenser
- Touch-free splash-mount soap dispenser
- 4" swivel casters (two w/brake) with non-marking tread—weight capacity of 150 lbs. (68.0 kg) per caster
- 5-gallon fresh water tank
- 7-gallon soiled water tank
- Box marine edge top





Item No.: _____
 Project No.: _____
 S.I.S. No.: _____

Touch-Free Portable Hand Sinks

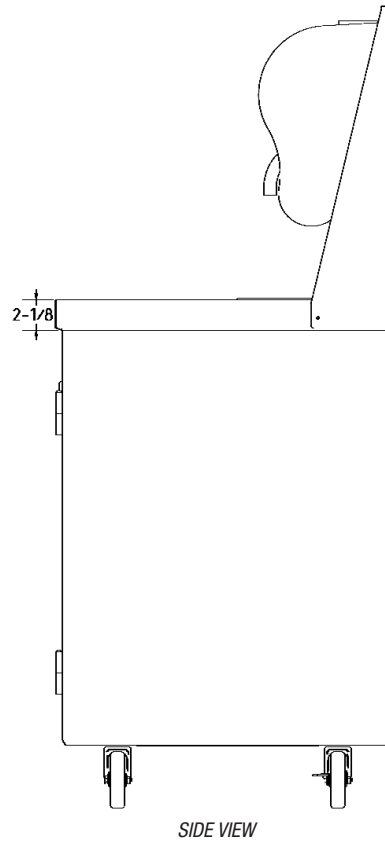
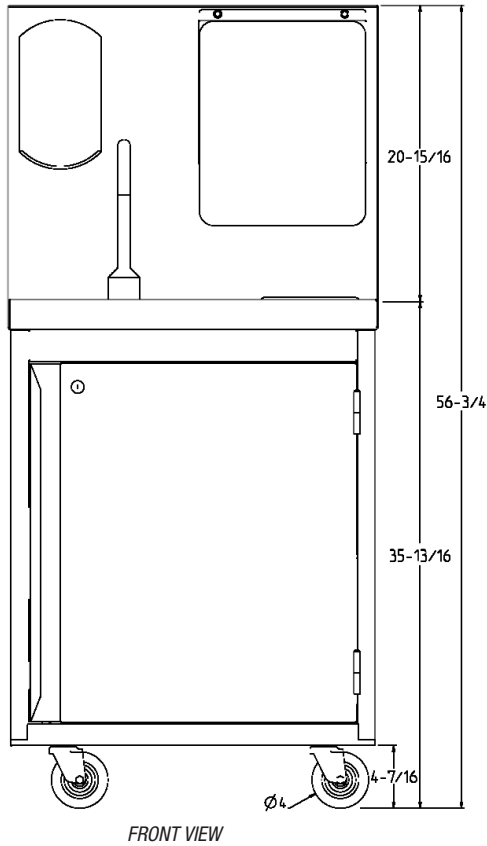
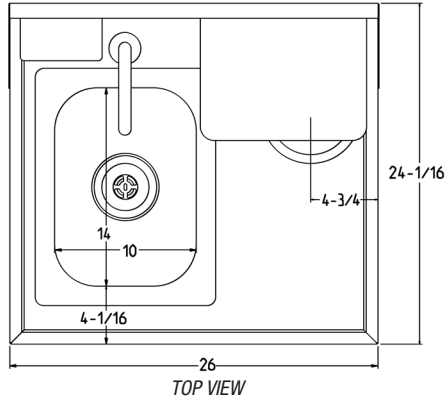

overall size (W x L x H)		sink size (W x L x D)		without Water Heater			with Water Heater		
in.	mm	in.	mm	lbs.	kg	model #	lbs.	kg	model #
24" x 26" x 56 3/4"	610 x 660 x 1442	14" x 10" x 5"	356 x 256 x 127	209	94.8	PHS-S-C-TF	237	107.5	PHS-S-H-TF

EAGLE GROUP
 100 Industrial Boulevard, Clayton, DE 19938-8903 USA
 Phone: 302-653-3000 or 800-441-8440 • Fax: 302-653-2065
 www.eaglegrp.com • www.eaglehmc.com

Printed in U.S.A.
 ©2024 by Eagle Group
 Rev. 10/24

Spec sheets available for viewing, printing or downloading from our online literature library at our websites

Although every attempt has been made to ensure the accuracy of the information provided, we cannot be held responsible for typographical or printing errors. Information and specifications are subject to change without notice. Please confirm at time of order.