



Profit from the Eagle Advantage®

Specification Sheet

Short Form Specifications

Eagle Group Stationary Staging Shelving, model _____ . Knockdown unit contains five patented QuadTruss® wire shelves with clear inlays, two 63" posts, two 54" posts, five clear shelf markers and sign. Available in chrome or black epoxy finish.



Options / Accessories

- Dividers
- Enclosure panels
- Additional shelf markers
- Other finishes

EAGLE GROUP

100 Industrial Boulevard, Clayton, DE 19938-8903 USA
 Phone: 302-653-3000 • 800-441-8440 • Fax: 302-653-2065
www.eaglegrp.com
www.eaglehmc.com

For custom configuration or fabrication needs, contact our **SpecFAB®** Division.
 Phone: 302-653-3000 • Fax: 302-653-2065 • e-mail: quotes@eaglegrp.com

Item No.:	_____
Project No.:	_____
S.I.S. No.:	_____

Mobile Pick-Up / Stationary Staging Shelving

MODELS:

- TGS1824BL-5
- TGS1824C-5
- TGS1836BL-5
- TGS1836C-5
- TGS1848BL-5
- TGS1848C-5

Design and Construction Features

- Modular shelving system adjustable on 1" increments
- Five (5) wire shelves with patented QuadTruss® design (patent #5,390,803)
- Five (5) clear shelf inlays
- Five (5) clear shelf markers
- Two (2) 63" front posts
- Two (5) 54" rear posts
- All posts are 1" diameter
- Mobile order signage
- Chrome or black epoxy finish





Item No.: _____
 Project No.: _____
 S.I.S. No.: _____

Mobile Pick-Up / Stationary Staging Shelving

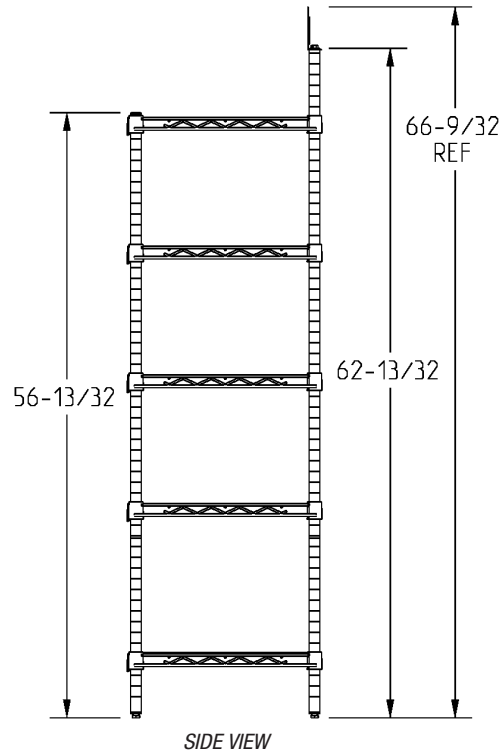
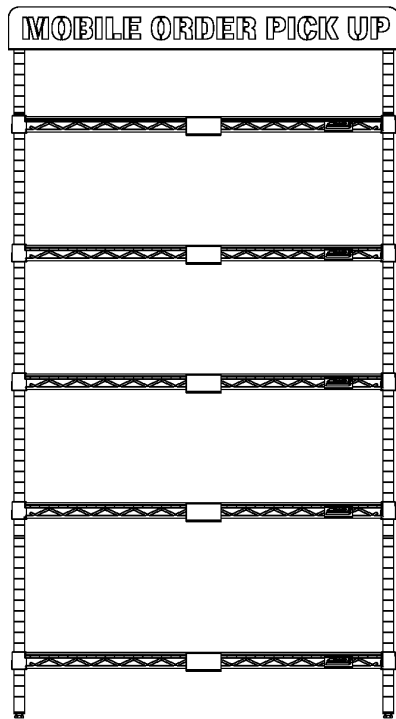
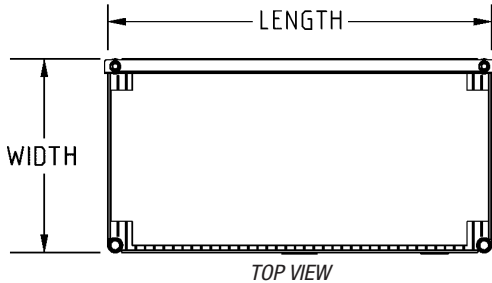

width		length		weight		Chrome	Black
in.	mm	in.	mm	lbs.	kg	model #	model #
18"	457	24"	608	65	29.5	TGS1824C-5	TGS1824BL-5
18"	457	36"	914	72	32.6	TGS1836C-5	TGS1836BL-5
18"	457	48"	1219	95	43.1	TGS1848C-5	TGS1848BL-5

EAGLE GROUP
 100 Industrial Boulevard, Clayton, DE 19938-8903 USA
 Phone: 302-653-3000 or 800-441-8440 • Fax: 302-653-2065
 www.eaglegrp.com • www.eaglehmc.com

Printed in U.S.A.
 ©2024 by Eagle Group

Rev. 10/24

Spec sheets available for viewing, printing or downloading from our online literature library at our websites

Although every attempt has been made to ensure the accuracy of the information provided, we cannot be held responsible for typographical or printing errors. Information and specifications are subject to change without notice. Please confirm at time of order.