

Biscuit Workstation

ASSEMBLY INSTRUCTIONS

CAUTION

INSPECT CONTENTS IMMEDIATELY AND FILE CLAIM WITH DELIVERING CARRIER FOR ANY DAMAGE. **SAVE YOUR BOX AND ALL PACKING MATERIALS.** YOU ARE RESPONSIBLE FOR DAMAGE TO YOUR UNIT IF RETURNED IMPROPERLY PACKED.

Thank you for your purchase. Before assembly, read this instruction sheet carefully. After reading, be sure to store this instruction in a safe place, should it be needed for future reference.

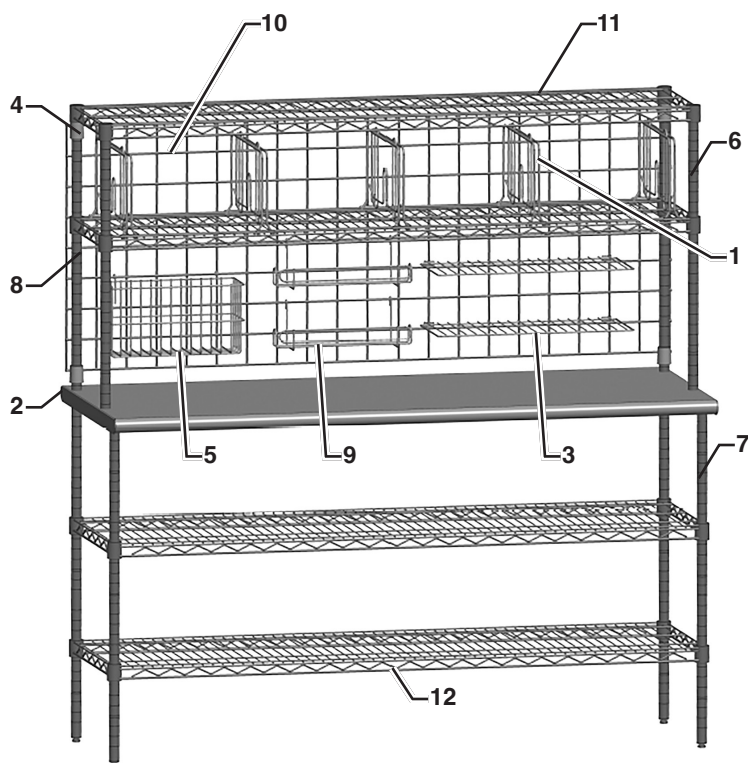

Parts List

| <i>item #</i> | <i>qty</i> | <i>description</i> |
|---------------|------------|------------------------------|
| #1 | 5 | Shelf Divider 14" Mild Steel |
| #2 | 1 | Tabletop |
| #3 | 2 | Light Duty Shelf |
| #4 | 4 | Grid Panel Clamp Asm |
| #5 | 1 | Wire Basket |
| #6 | 2 | 29" Post |
| #7 | 2 | 33" Post |
| #8 | 2 | 63" Post |
| #9 | 2 | Spice Rack |
| #10 | 1 | Wall Grid |
| #11 | 2 | Overshelf |
| #12 | 2 | Undershelf |
| #13 | 16 | Pair of split sleeves |

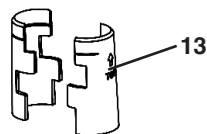

(continued on next page)

Biscuit Workstation

ASSEMBLY INSTRUCTIONS

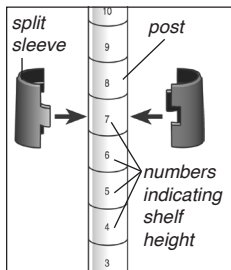

figure 1

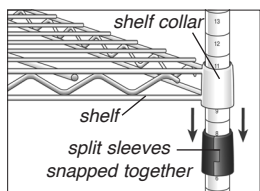

figure 2

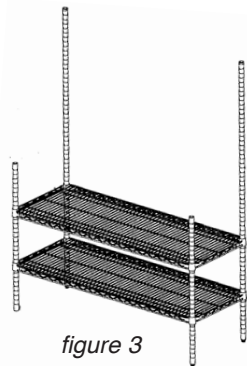

figure 3

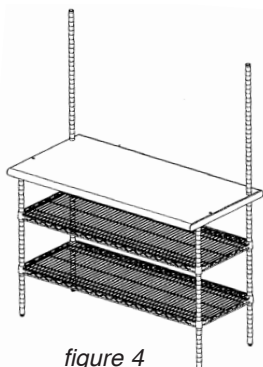

figure 4

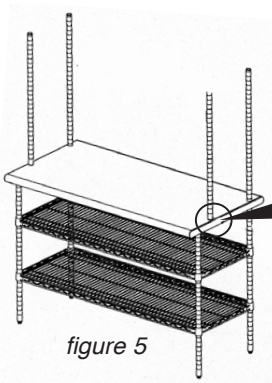

figure 5

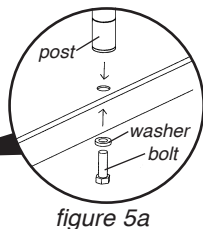

figure 5a

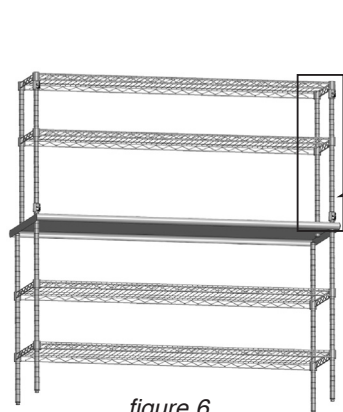
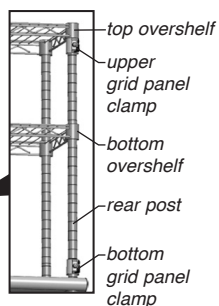

figure 6
(rear view)



1) Undershelves

Note: Install the bottom undershelf first.

- Referencing numbers on posts, snap plastic tapered split sleeves onto each post (the two longest posts go in the back, and two 33" in the front) at desired location of undershelf. The thicker part of the taper goes toward the bottom. Refer to figures 1 and 2. Make sure rib on split sleeve is seated into a groove on the post.
- Lower the undershelf onto the posts until the plastic tapered split sleeves are snugly fitted within the shelf collars. Repeat this step for second undershelf. Refer to figure 3.

Note: The wider wire shelves are the undershelves. The narrow wire shelves are the overshelves.

2) Stainless Steel Tabletop

- Snap the plastic tapered split sleeves onto the very top of the shorter posts. Be sure that the plastic tapered split sleeves get snapped onto the same groove on the longer posts.
- Lower the tabletop over the longer posts until the tabletop is seated snugly on the split sleeves. Refer to figure 4.

3) Front Posts for Wire Overshelves

Bolt the two 29" posts onto the tabletop. One end of these posts has a nut welded in it. This is the end for the bolt. Refer to figure 5a.

4) Overshelves and Grid Panel Clamps

Install the bottom grid panel clamps first.

- Snap split sleeves onto bottommost groove of each rear post.
- Ensuring that the lettering is rightside-up, lower grid panel clamp onto each rear post until the split sleeves are snugly fitted within the grid panel clamps. Make sure the clamps are facing to the rear.

Install the bottom overshelf.

- Referencing numbers on posts, snap split sleeves onto each post at desired location of overshelf.
- Lower the overshelf onto the posts until the plastic tapered split sleeves are snugly fitted within the shelf collars.

Install the upper grid panel clamps.

- Snap split sleeves onto THIRD groove from the top of each rear post.
- Lower the grid panel clamp onto each rear post until the plastic split sleeves are snugly fitted within. Make sure the clamps are facing to the rear.

Install the top overshelf.

- Snap split sleeves onto top groove of each rear post.
- Lower the overshelf onto the posts until the plastic split sleeves are snugly fitted within the shelf collars.

Refer to figure 6.

5) Seat Shelves

Securely seat all shelves by lightly tapping with a rubber mallet to secure shelving to split sleeves and posts.

(continued on next page)

Biscuit Workstation

ASSEMBLY INSTRUCTIONS

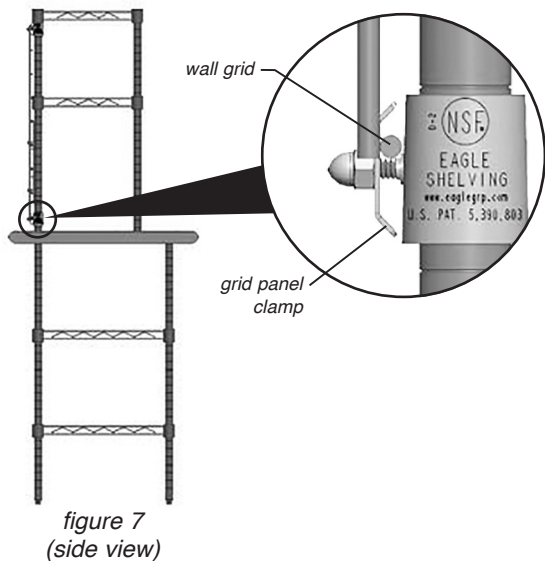

6) Wall Grid

- Attach the wall grid to the grid panel clamps, as shown in figure 7.
- On each grid panel clamp, tighten the screw to secure the grid in place.

7) Light Duty Utility Shelf

- Hook Light Duty Utility Shelf onto the Wall Grid, as shown.

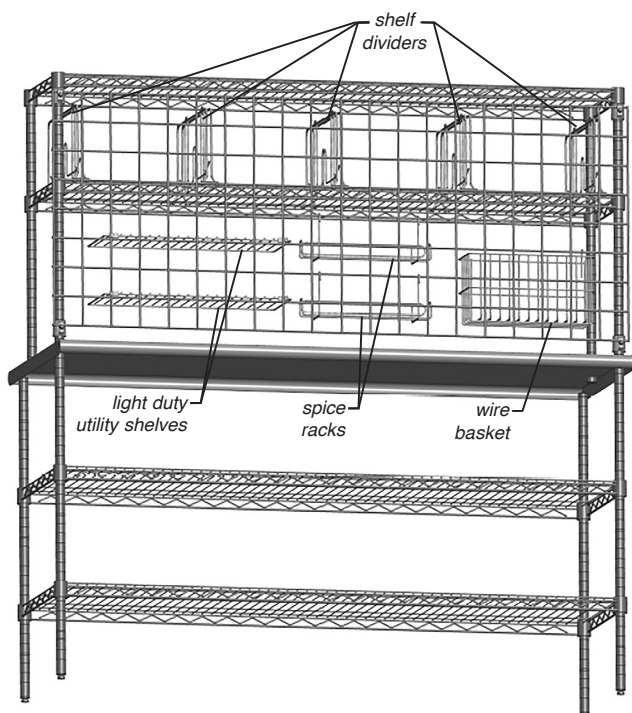
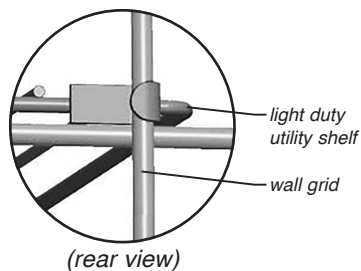

8) Spice Rack and Basket

- Hook both Spice Racks onto the Wall Grid, as shown.
- Hook Wire Basket onto the Wall Grid, as shown.

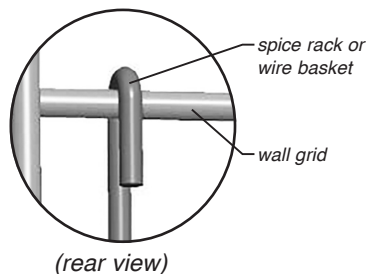

9) Shelf Dividers

- The shelf divider attaches to the front and back of the overhead shelves, as shown.
- Repeat this step on remaining dividers.

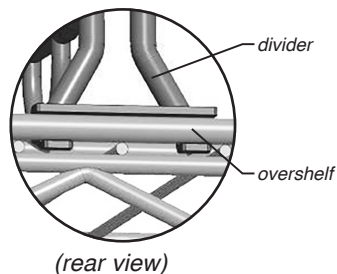

(End) Assembly is complete.

Biscuit Workstation

ASSEMBLY INSTRUCTIONS



- 100 Industrial Boulevard, Clayton, Delaware 19938-8903 U.S.A.
- Phone: 302/653-3000 • 800/441-8440 • Fax: 302/653-2065
- www.eaglegrp.com • www.eaglemhc.com