



Profit from the Eagle Advantage®

Specification Sheet

Short Form Specifications

Eagle Group Corner Mop Sink with Drop Edge, model _____ . Constructed of type 304 stainless steel, with 8"- or 12"-deep fabricated bowl with drop edge. Includes full apron and drain with flat strainer plate.

Item No.:	_____
Project No.:	_____
S.I.S. No.:	_____

Corner Mop Sinks with Drop Front Edge

MODELS:

- | | |
|---------------------------------------|---------------------------------|
| <input type="checkbox"/> F2121-8-CDE | <input type="checkbox"/> 312688 |
| <input type="checkbox"/> F2121-12-CDE | <input type="checkbox"/> 312689 |
| <input type="checkbox"/> F2424-8-CDE | <input type="checkbox"/> 312690 |
| <input type="checkbox"/> F2424-12-CDE | <input type="checkbox"/> 321561 |



corner mop sink
#F2121-8-CDE

Design & Construction Features:

- Heavy gauge type 304 stainless steel bowl and skirt
- Fabricated bowl is fully welded and polished
- Bowl is creased to improve drainage and prevent pooling
- Front is dropped 3"
- Bowl is fully welded in skirt
- Drain is 2" brass no-caulk shower drain with 4½" stainless steel strainer

Options / Accessories

- 3-Pole mop holder
- 4-Pole mop holder
- Hose and bracket
- Service faucet

EAGLE GROUP

100 Industrial Boulevard, Clayton, DE 19938-8903 USA
 Phone: 302-653-3000 • 800-441-8440 • Fax: 302-653-2065
 www.eaglegrp.com
 www.eaglemhc.com



For custom configuration or fabrication needs, contact our **SpecFAB®** Division.
 Phone: 302-653-3000 • Fax: 302-653-2065 • e-mail: quotes@eaglegrp.com

EG20.08A Rev. 05/24

Spec sheets available for viewing, printing or downloading from our online literature library at our websites

Item No.: _____
Project No.: _____
S.I.S. No.: _____

Corner Mop Sinks with Drop Front Edge

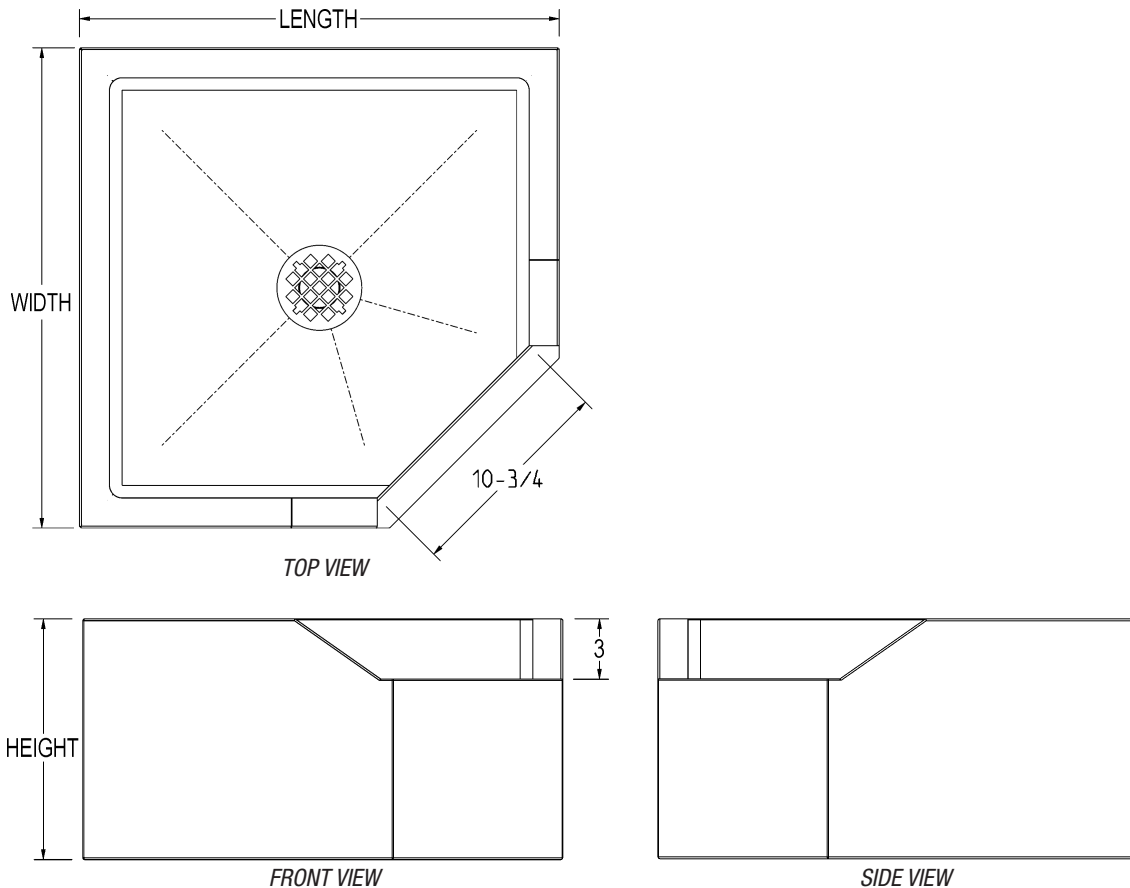

model #	bowl size		overall size		weight	
	width in.	length x depth mm	width in.	length x height mm	lbs.	kg
F2121-8-CDE	21" x 21" x 8"	533 x 533 x 203	24" x 24" x 12"	610 x 610 x 305	76	34.5
F2121-12-CDE	21" x 21" x 12"	533 x 533 x 305	24" x 24" x 16"	610 x 610 x 406	89	40.3
F2424-8-CDE	24" x 24" x 8"	610 x 610 x 203	27" x 27" x 12"	686 x 686 x 305	91	41.3
F2424-12-CDE	24" x 24" x 12"	610 x 610 x 305	27" x 27" x 16"	686 x 686 x 406	97	44.0

Optional Accessories

model #	description	weight	
		lbs.	kg
312688	3-pole mop holder, 18" x 4" (457 x 102mm), projects out 1 3/8" (35mm)	4	1.8
321561	4-pole mop holder, 24" x 4" (610 x 102mm), projects out 1" (25mm)	4.5	2.0
312689	Hose & bracket, 30" (762mm) length	8	3.6
312690	Service faucet, 8" (203mm) center, 1/2" (13mm) NPT female inlets, comes with vacuum breaker	11	5.0

EAGLE GROUP

100 Industrial Boulevard, Clayton, DE 19938-8903 USA

Phone: 302-653-3000 or 800-441-8440 • Fax: 302-653-2065

www.eaglegrp.com • www.eaglehmc.com

Printed in U.S.A.
©2024 by Eagle Group

Rev. 05/24

Spec sheets available for viewing, printing or downloading from our online literature library at our websites

Although every attempt has been made to ensure the accuracy of the information provided, we cannot be held responsible for typographical or printing errors. Information and specifications are subject to change without notice. Please confirm at time of order.