

Kitchen Wine Cart

ASSEMBLY INSTRUCTIONS

CAUTION

INSPECT CONTENTS IMMEDIATELY AND FILE CLAIM WITH DELIVERING CARRIER FOR ANY DAMAGE. **SAVE YOUR BOX AND ALL PACKING MATERIALS.** YOU ARE RESPONSIBLE FOR DAMAGE TO YOUR UNIT IF RETURNED IMPROPERLY PACKED.

HELPFUL SUGGESTION:

Installation is easier if all posts are marked first to indicate desired shelf locations. Lay posts on floor, with top or bottom of posts against a wall or straight edge. Mark all posts, using a magic marker or grease pencil.

Step 1 - Assemble casters to posts.

Drive in caster using a hammer or mallet. Several solid blows are usually required.

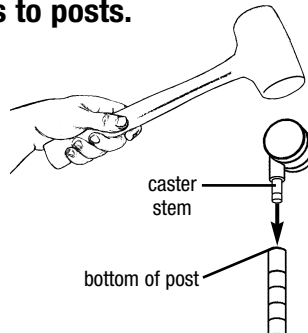

Step 2 - Attach split sleeves (for bottom shelf) to posts.

- The wider part of the taper goes toward the bottom.
 - Make sure rib on split sleeve is seated into a groove on the post.
- Note: The number covered by the split sleeve indicates approximate height of shelf.

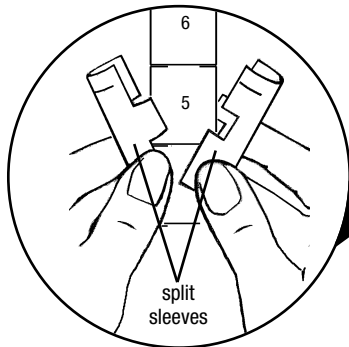

Step 3 - Mount bottom shelf.

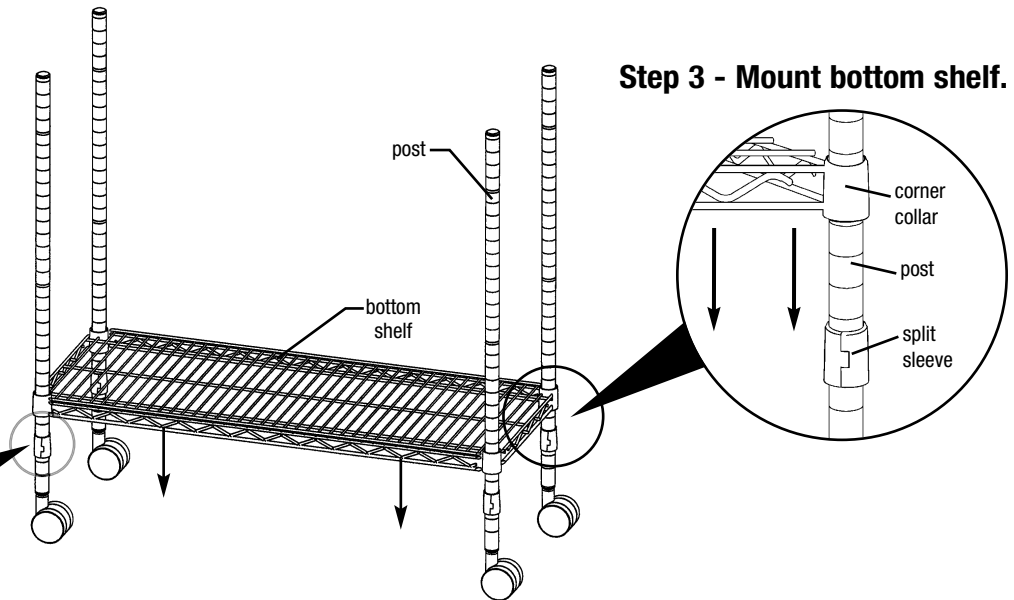

(continued on back page)

EG10098 Revised 04/24

Kitchen Wine Cart

ASSEMBLY INSTRUCTIONS

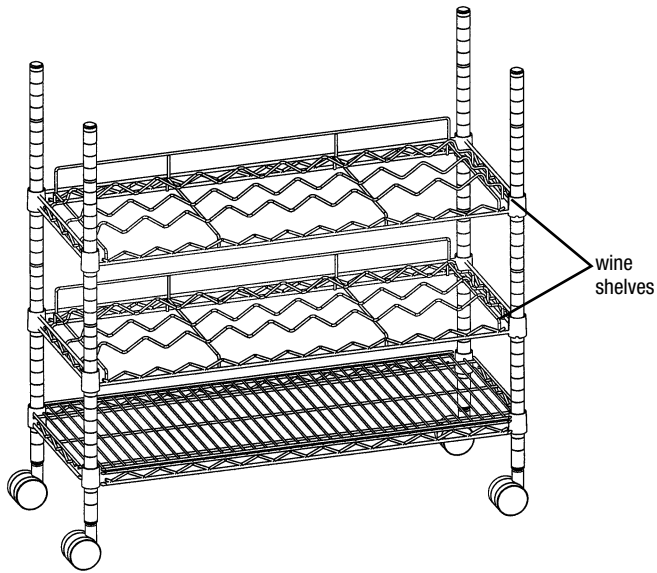

Step 4: Mount wine shelves at desired heights.

Repeat Steps 2 & 3 (front page), working from bottom to top.

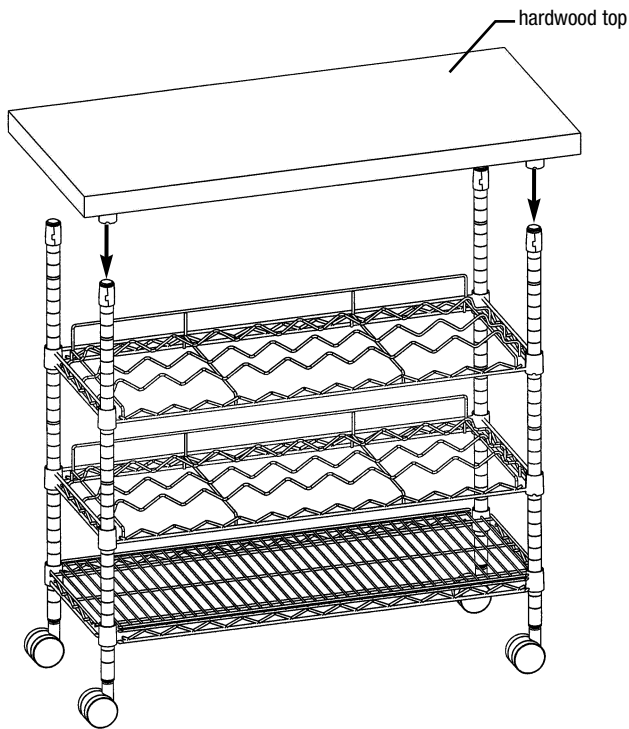

Step 5: Mount hardwood top.

Repeat Steps 2 & 3 (front page), attaching split sleeves at the topmost grooves of posts.

Assembly is complete.

(End)