

#SK-17 Heat Lamp Display Kit

ASSEMBLY INSTRUCTIONS

CAUTION

INSPECT CONTENTS IMMEDIATELY AND FILE CLAIM WITH DELIVERING CARRIER FOR ANY DAMAGE.
SAVE YOUR BOX AND ALL PACKING MATERIALS.
YOU ARE RESPONSIBLE FOR DAMAGE TO YOUR UNIT IF RETURNED IMPROPERLY PACKED.

Parts List

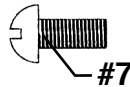
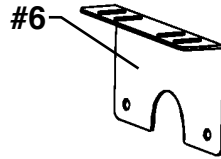
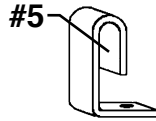
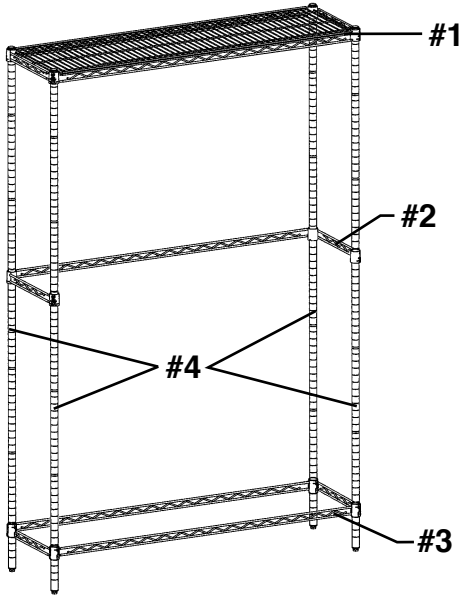

#	qty	description
#1	1	14" x 48" wire shelf
#2	1	14" x 48" three-sided truss frame
#3	1	14" x 48" four-sided truss frame
#4	4	74" posts
#5	4	hooks
#6	2	heat lamp brackets
#7	4	screws, #8-32 x 3/8"
#8	3	bags of 4 split sleeves

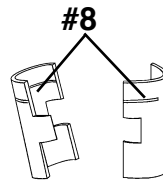

Step 1 - Attach split sleeves (for bottom 4-sided truss frame) to posts.

Snap split sleeve onto each post at groove #5 (the wider part of the taper goes toward the bottom).

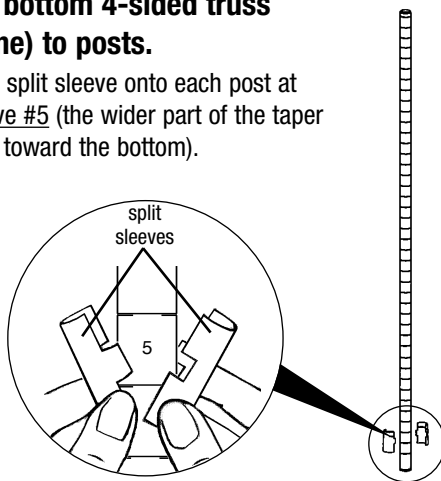

Step 2 - Assemble 4-sided truss frame to posts.

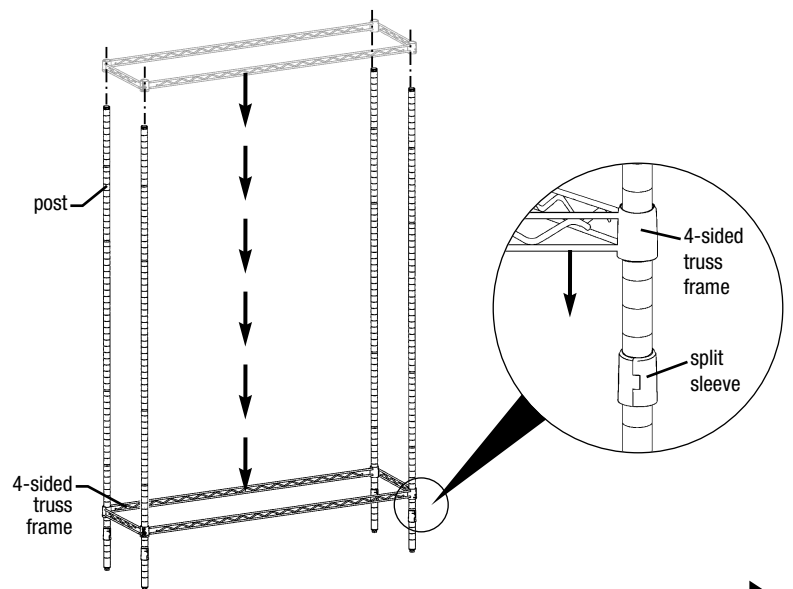

(continued on back page)

EG9858 Revised 12/23

#SK-17 Heat Lamp Display Kit

ASSEMBLY INSTRUCTIONS

Step 3 - Attach split sleeves (for 3-sided frame) to posts.

Snap split sleeve onto each post at groove #35.

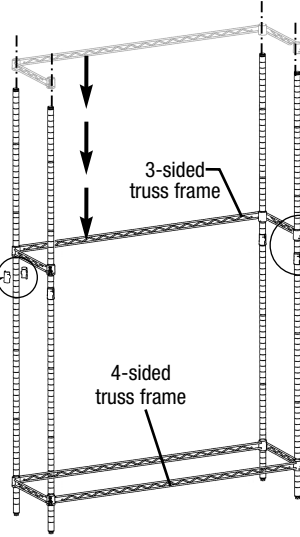
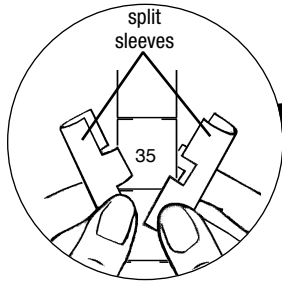

Step 4 - Assemble 3-sided truss frame to posts.

Note: The open side of the 3-sided truss frame indicates the front side of the unit.

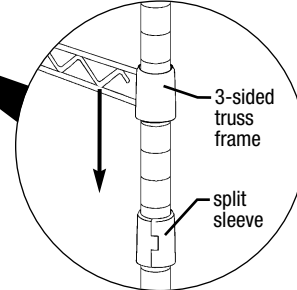

Step 5 - Attach split sleeves (for top shelf) to posts.

Snap split sleeve onto each post at the topmost groove.

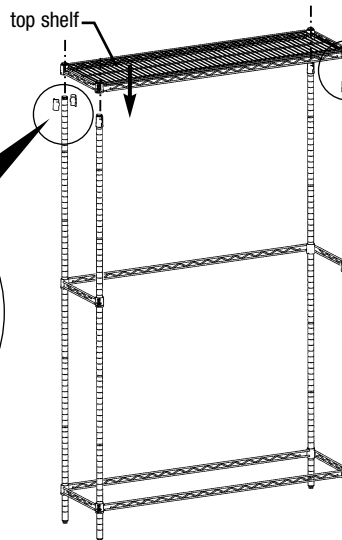
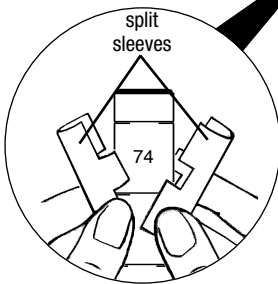

Step 6 - Assemble top shelf to posts.

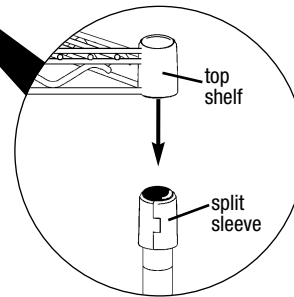

Step 7 - Install 36" heat lamp*.

Referring to illustration below, back screws out of heat lamp, per end. Attach brackets as shown.

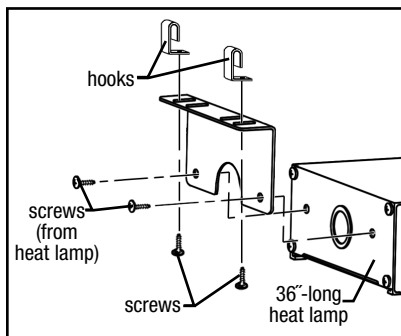

Hook heat lamp* onto underside of top shelf. Assembly is complete.

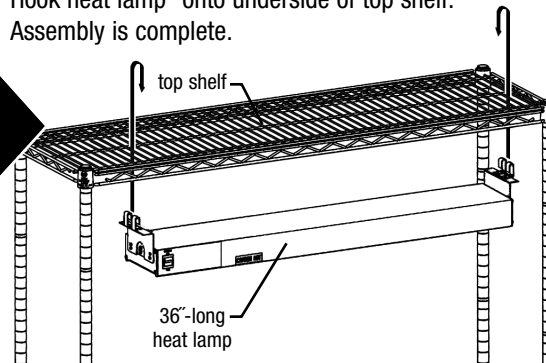

Display unit accommodates packaged heat lamps* up to 60" length.

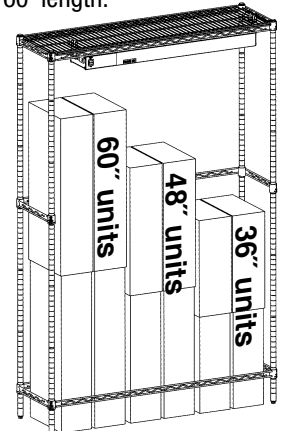

(End)

* Heat lamps sold separately.

EAGLE
GROUP
Profit from the Eagle Advantage®

• 100 Industrial Boulevard, Clayton, Delaware 19938-8903 U.S.A.
• Phone: 302/653-3000 • 800/441-8440 • Fax: 302/653-2065
• www.eaglegrp.com • www.eaglehmc.com

Eagle Foodservice Equipment, Eagle MHC, and SpecFAB® are divisions of Eagle Group. ©2023 by the Eagle Group