

# Front Case Merchandise Shelving with Cantilever Overshelf

## ASSEMBLY INSTRUCTIONS

### CAUTION

INSPECT CONTENTS IMMEDIATELY AND FILE CLAIM WITH DELIVERING CARRIER FOR ANY DAMAGE. **SAVE YOUR BOX AND ALL PACKING MATERIALS.** YOU ARE RESPONSIBLE FOR DAMAGE TO YOUR UNIT IF RETURNED IMPROPERLY PACKED.

#### Step 1 - Attach split sleeves (for shelf) to topmost groove on front posts and to #7 groove on rear posts.

- The wider part of the taper goes toward the bottom.
- Make sure rib on split sleeve is seated into a groove on the post.

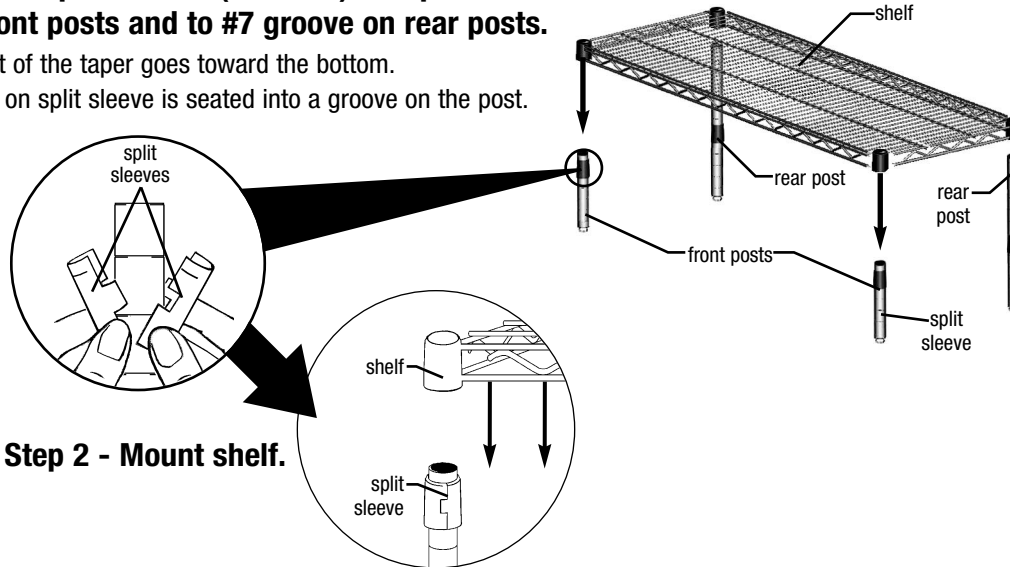

#### Step 2 - Mount shelf.

#### Step 3 - Attach split sleeves (for cantilever overshelf) to topmost groove on rear posts.

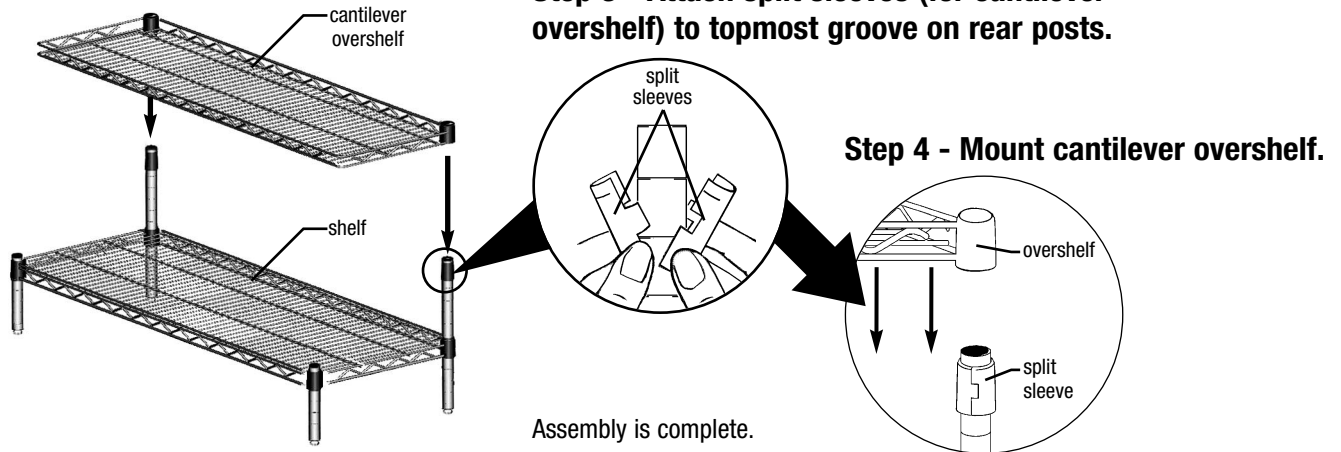

### LOADING CRITERIA

- Place heaviest items on bottom shelf.
- Load bottom shelf first.
- Cantilever shelf NOT to exceed 15 lbs. per square foot.

**Failure to follow this criteria can result in property damage or personal injury.**

(End)

# Front Case Merchandise Shelving with Standard Shelves

## ASSEMBLY INSTRUCTIONS

### CAUTION

INSPECT CONTENTS IMMEDIATELY AND FILE CLAIM WITH DELIVERING CARRIER FOR ANY DAMAGE. **SAVE YOUR BOX AND ALL PACKING MATERIALS.** YOU ARE RESPONSIBLE FOR DAMAGE TO YOUR UNIT IF RETURNED IMPROPERLY PACKED.

#### Step 1 - Attach split sleeves (for shelf) to #7 groove on all posts.

- The wider part of the taper goes toward the bottom.
- Make sure rib on split sleeve is seated into a groove on the post.

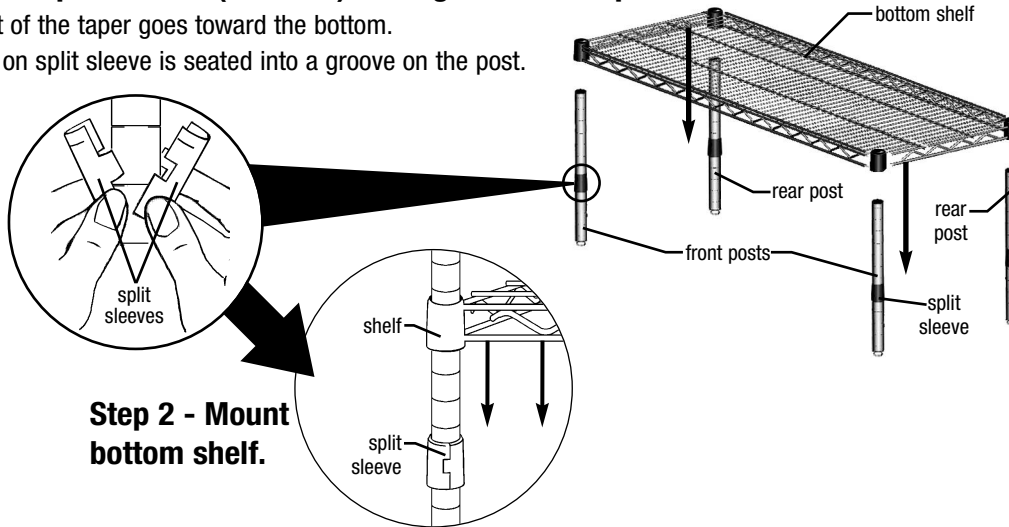

#### Step 2 - Mount bottom shelf.

#### Step 3 - Attach split sleeves (for overshelf) to topmost groove on rear posts.

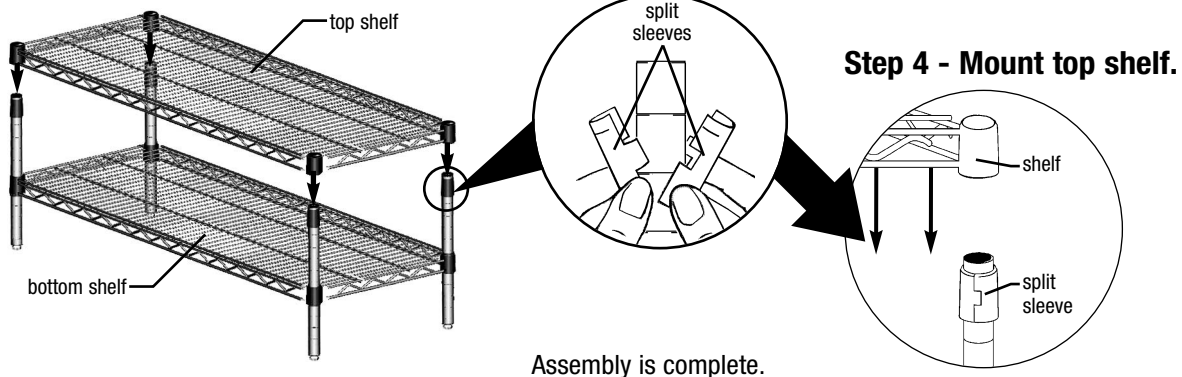

#### Step 4 - Mount top shelf.

Assembly is complete.



### LOADING CRITERIA



- Place heaviest items on bottom shelf.
- Load bottom shelf first.
- Weight capacity NOT to exceed 800 lbs. for shelves up to 48" long, 600 lbs. for shelves 54" and longer.

***Failure to follow this criteria can result in property damage or personal injury.***

(End)