

Hand Sink Display

ASSEMBLY INSTRUCTIONS

CAUTION

INSPECT CONTENTS IMMEDIATELY AND FILE CLAIM WITH DELIVERING CARRIER FOR ANY DAMAGE. **SAVE YOUR BOX AND ALL PACKING MATERIALS.** YOU ARE RESPONSIBLE FOR DAMAGE TO YOUR UNIT IF RETURNED IMPROPERLY PACKED.

Step 1 - Prepare the pedestal.

- Unfold pedestal and stand upright.
- Bend the bottom flanges inward as shown.
- Insert pocket into slots as shown, then fold pocket flanges to lock pocket into place.

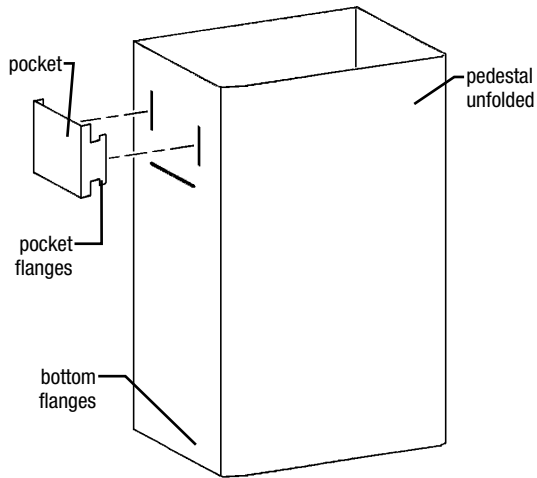

Step 2 - Set hand sink inside pedestal.

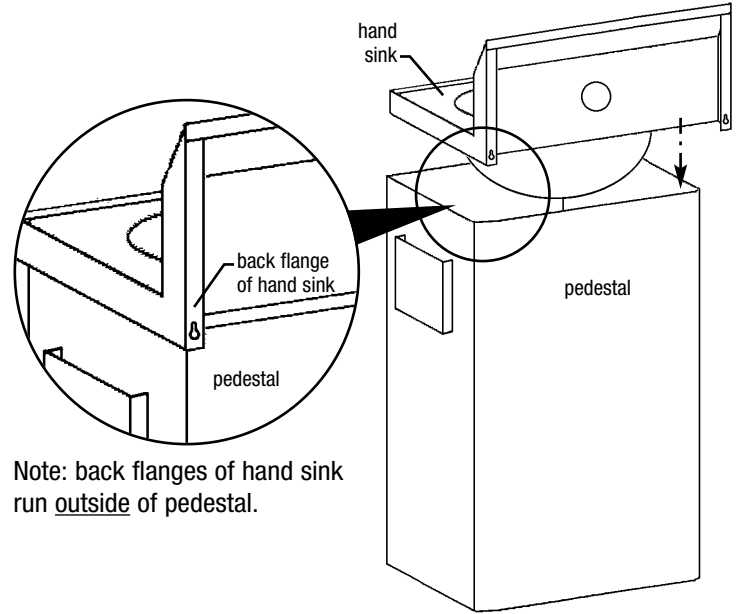

Step 3 - Install header.

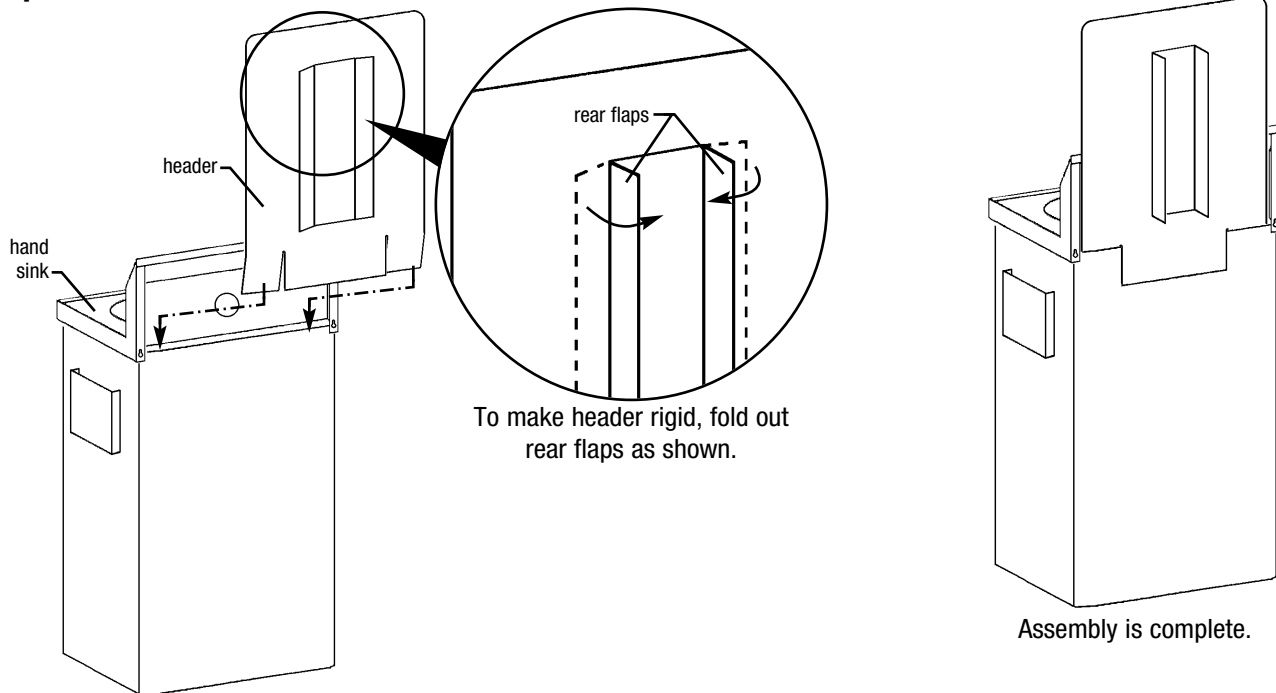

EG10063 Revised 09/23