



Profit from the Eagle Advantage®

Specification Sheet

Short Form Specifications

Eagle Electric Hot Food Gang Drop-In Unit, model _____. Heavy gauge stainless steel top with overhang on all four sides. Galvanized steel body surrounded with fiberglass insulation. Each heated well accommodates a 12" x 20" food pan, and features a 750-watt exposed heating element. All units feature infinite controls, with high and low selections plus eight other temperature settings. Controls are recessed into control panel.

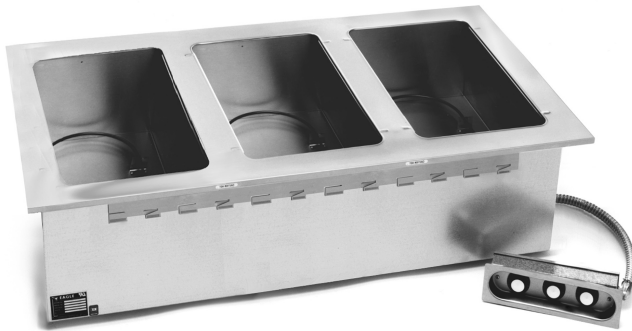

model # GDI-3-240 unit

Options / Accessories

- Rolltop cover
- Food pans/insets
- Top adapters
- Spillage pans

EAGLE GROUP

100 Industrial Boulevard, Clayton, DE 19938-8903 USA
 Phone: 302-653-3000 • 800-441-8440 • Fax: 302-653-2065
www.eaglegrp.com
www.eaglemhc.com

For custom configuration or fabrication needs, contact our **SpecFAB® Division**.
 Phone: 302-653-3000 • Fax: 302-653-2065 • e-mail: quotes@eaglegrp.com

Item No.:	_____
Project No.:	_____
S.I.S. No.:	_____

Electric Hot Food Gang Drop-In Units

MODELS:

- | | | | |
|------------------------------------|------------------------------------|------------------------------------|---------------------------------|
| <input type="checkbox"/> GDI-2-208 | <input type="checkbox"/> GDI-3-240 | <input type="checkbox"/> GDI-5-208 | <input type="checkbox"/> 305174 |
| <input type="checkbox"/> GDI-2-240 | <input type="checkbox"/> GDI-4-208 | <input type="checkbox"/> GDI-5-240 | <input type="checkbox"/> DVE-50 |
| <input type="checkbox"/> GDI-3-208 | <input type="checkbox"/> GDI-4-240 | <input type="checkbox"/> 305173 | <input type="checkbox"/> DVE-75 |

Top and Body

- 22 gauge type 430 stainless steel top with 1" (25mm) overhang on all four side with reinforced angles.
- 20 gauge galvanized steel wraparound.

Heat Compartments

- Each heat compartment accommodates a 12" x 20" (305 x 508mm) food pan.
- 750-watt exposed rectangular-shaped heating element per heat compartment.
- Fiberglass insulation on all four sides and bottom, with heating elements above the insulated bottom.

Controls

- All units feature infinite controls which offer high and low selections along with eight other temperature settings.
- Control knobs are recessed into a one-piece, front-mounted control panel.

Electrical

- Flexible conduit connecting the body enclosure and control panel is 20" (508mm) on all models.
- All wiring terminates in a junction box.
- All units are single phase. Three-phase wiring available.
- ALL UNITS ARE DESIGNED FOR FIELD WIRING.

Certifications / Approvals



Note: Not UL-recognized for Canada





Profit from the Eagle Advantage®

Item No.: _____
 Project No.: _____
 S.I.S. No.: _____

Electric Hot Food Gang Drop-In Units

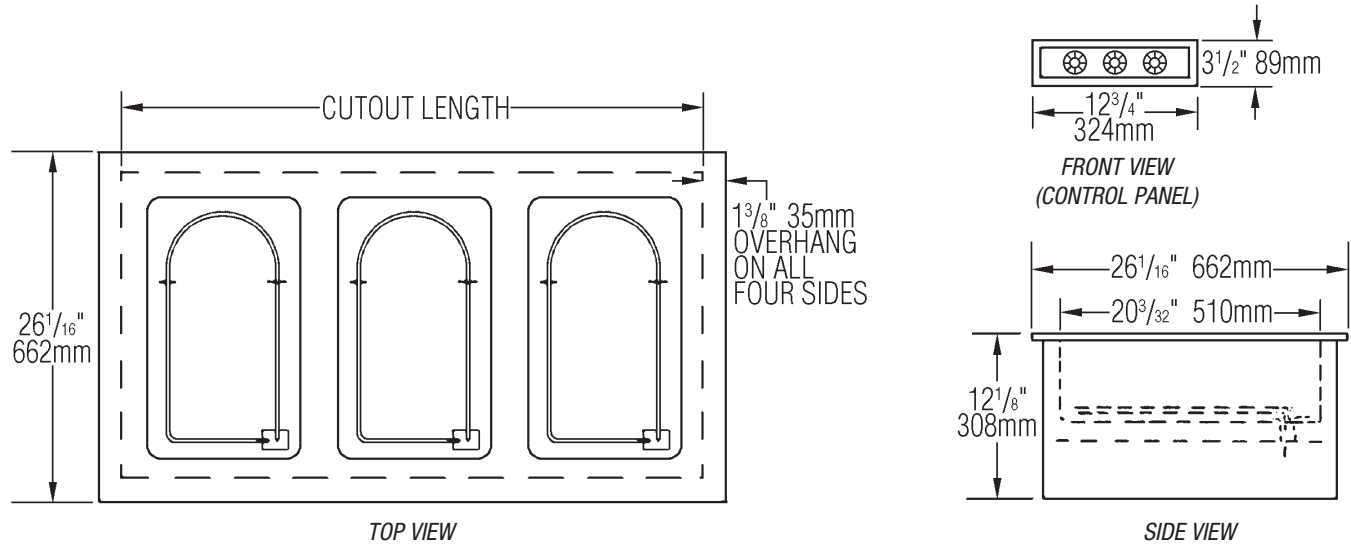

(model #GDI-3-240 shown)

# of pan openings	# of panels	overall dimensions in.	overall dimensions mm	fits cutout measuring in.	fits cutout measuring mm	type of remote control panel(s), and cutout dimensions	electrical data	model #
2	1	26 ¹ / ₁₆ " x 33 ¹ / ₂ "	662 x 851	23 ³ / ₁₆ " x 30 ³ / ₄ "	592 x 781	double, 8 ³ / ₁₆ " x 2 ¹ / ₁₆ " (213 x 68mm)	208V, 7.2A, 1500W 240V, 6.25A, 1500W	GDI-2-208 GDI-2-240
3	1	26 ¹ / ₁₆ " x 48 ⁷ / ₁₆ "	662 x 1241	23 ³ / ₁₆ " x 46 ⁷ / ₁₆ "	592 x 1172	triple, 11 ¹³ / ₁₆ " x 2 ¹ / ₁₆ " (300 x 68mm)	208V, 10.8A, 2250W 240V, 9.38A, 2250W	GDI-3-208 GDI-3-240
4	2	26 ¹ / ₁₆ " x 64 ¹ / ₄ "	662 x 1632	23 ³ / ₁₆ " x 61 ¹ / ₂ "	592 x 1562	double, 8 ³ / ₁₆ " x 2 ¹ / ₁₆ " (213 x 68mm)	208V, 14.4A, 3000W 240V, 12.5A, 3000W	GDI-4-208 GDI-4-240
5	2	26 ¹ / ₁₆ " x 79 ¹ / ₄ "	662 x 2018	23 ³ / ₁₆ " x 76 ³ / ₁₆ "	592 x 1945	double—8 ³ / ₁₆ " x 2 ¹ / ₁₆ " (213 x 68mm), & triple—11 ¹³ / ₁₆ " x 2 ¹ / ₁₆ " (300 x 68mm)	208V, 18.0A, 3750W 240V, 15.6A, 3750W	GDI-5-208 GDI-5-240

NOTE: 240-volt units will not allow field wiring to 208 volts.

Spillage Pans required for wet application

- Deep-drawn, fully-covered.
- 6¹/₂" (165mm) deep.



description	weight		model #
	lbs.	kg	
stainless steel	7	3.2	302027
aluminum	3	1.4	304141

Replacement Recessed Control Panels

Punched. Stainless steel construction.

description	cutout dimensions		model #
	in.	mm	
double	8 ³ / ₁₆ " x 2 ¹ / ₁₆ "	213 x 68	305173
triple	11 ¹³ / ₁₆ " x 2 ¹ / ₁₆ "	300 x 68	305174

Drain Valve Extensions

With ball valve. Adjusts from 7" to 28" (178 to 711mm). 2³/₄" (70mm)-diameter cutout required for handle.

model #	description
DVE-50	fits 1/2" valve
DVE-75	fits 3/4" valve



EAGLE GROUP

100 Industrial Boulevard, Clayton, DE 19938-8903 USA

Phone: 302-653-3000 or 800-441-8440 • Fax: 302-653-2065

www.eaglegrp.com • www.eaglemhc.com

Printed in U.S.A.
 ©2024 by Eagle Group

Rev. 10/24

Spec sheets available for viewing, printing or downloading from our online literature library at our websites

Although every attempt has been made to ensure the accuracy of the information provided, we cannot be held responsible for typographical or printing errors. Information and specifications are subject to change without notice. Please confirm at time of order.