



Profit from the Eagle Advantage®

Phone: (800) 441-8440 • (302) 653-3000

FAX: (302) 653-2065

# Product Announcement

## Short Form Specifications

Eagle Group SPEC-BAR® Portable Bar, model # SBPB-CCS-6. Welded 1-1/2" type 300 stainless steel square tubular base construction. 80" length, 33" wide, 48" high with 34" work height. Fully mobile - standard 4" poly tread casters with brake. 12"-wide five-step liquor display with stainless and ABS construction with snap-on label cover. 12"-wide blender station with sink, workboard, wet waste drain, and blender shelf. 48" combination ice chest with separate insulated bottle and ice bin and double speed rail. Foamed-in-place construction and sliding cover. Storage for four (4) 20" x 20" x 4" glass racks. Bottle bin, ice bin, and workboard plumbed independently.

Item #:	_____
Model #:	_____
Project #:	_____
SIS #:	_____

EG8215 Rev. 10/21

### Design & Construction Features:

- Welded 1 1/2" type 300 stainless steel square tubular base construction
- Countertop is Corian® "Cosmos Prima"
- 4" casters with brake
- 5-shelf, 12" wide liquor display
- 12" blender station with workboard and blender shelf
- Ice bin with six-compartment bottle rack
- 15" x 35" x 10" ice bin with sliding cover
- 48" double speed rail
- Storage for four 20" x 20" x 4" glass racks

### Options

- Solid surface bar top
- Lift-up stainless steel countertops
- Laminate or powder coated panels

For custom configuration or fabrication needs, contact our **SpecFAB® Division**.

Phone: (302) 653-3000. FAX: (302) 653-2065.

E-mail: quotes@eaglegrp.com

## New SPEC-BAR® Portable Bar



*shown with optional lift-up stainless steel countertops on both ends*

*SPEC-BAR® Portable Bar combines Eagle Group's most popular back bar equipment with a rugged stainless steel tubular frame to create a compact and capable mobile workstation. The five-step liquor display and double speed rail provide ample storage. The blender station features a workboard with wet waste drain and blender shelf. The combination ice chest provides separate insulated bottle and ice bin.*





Profit from the Eagle Advantage®

# SPEC-BAR® Portable Bar

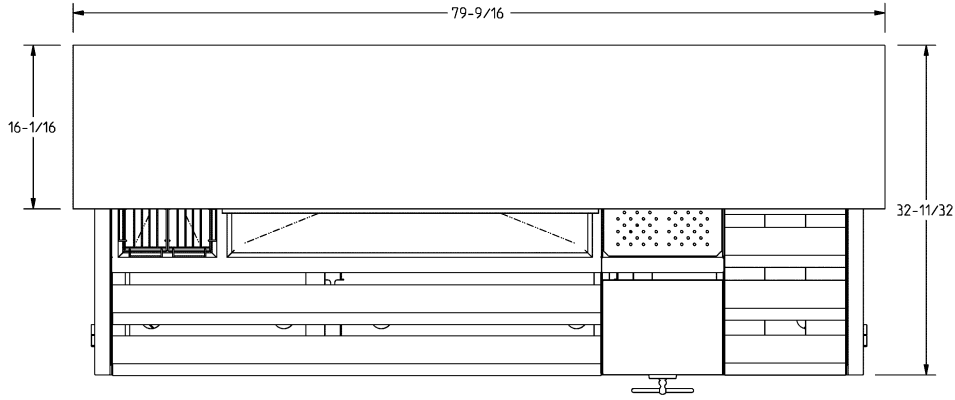

TOP VIEW

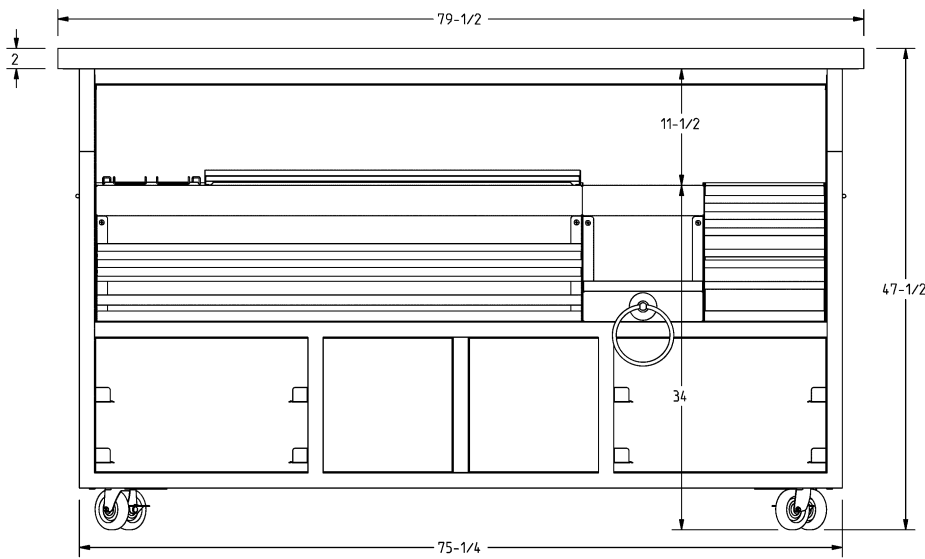

FRONT VIEW (WORKER'S SIDE)

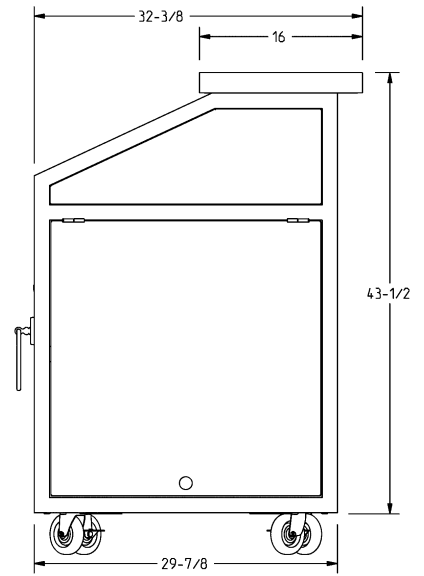

SIDE VIEW

O.A. size (length x width x height)		working height		model #
in.	mm	in.	mm	
80" x 33" x 48"	2032 x 838 x 1219	34"	864	SBPB-CCS-6

Printed in U.S.A.  
©2021 by Eagle Group

EG8215 Rev. 10/21

Phone: (800) 441-8440 or (302) 653-3000 • Fax: (302) 653-2065 • www.eaglegrp.com

Although every attempt has been made to ensure the accuracy of the information provided, we cannot be held responsible for typographical or printing errors. Information and specifications are subject to change without notice. Please confirm at time of order.