

Wall-Mounted Boat Racks

(Models #BRW4, BRW5, and BRW6)

ASSEMBLY INSTRUCTIONS

For models #BRW7 and BRW8, see page 3.

Parts List

#	qty	part #	description
#1	2	*	wire shelf
#2	*	R26-C	rod & tie
#3	8	n/a	collar plug
#4	*	A204297	clip hold down for rods
#5	2	PW33C**	33" posts
#6	4	A217323	top/bottom support
#7	4	303999	bolt 3/8-16 x 1 1/4"
#8	4	PWB14C	post-wall bracket

* Quantities and/or part numbers vary, depending on what is ordered.
** Please note that the following parts are included with part #PW33C:

#	qty	part #	description
#6	4	A217323	top/bottom support
#7	4	303999	bolt 3/8-16 x 1 1/4"
#8	4	PWB14C	post-wall bracket

Centerline Chart

Shelf Length	Centerline
48"	.46 ⁷ / ₁₆ "
60"	.58 ⁷ / ₁₆ "
72"	.70 ⁷ / ₁₆ "

1) Center Lines

Refer to chart at left to determine proper centerline distances between top/bottom supports and shelf brackets.

2) Top & Bottom Supports

- Mark bottom support location at desired height (see *figure 1*)—using a level to insure support is level—and then screw* bottom support into wall.
- To determine top support location, bolt the post to the bottom support on the wall, then bolt the top support to the post (see *figure 2*). **IMPORTANT:** Use a level to insure post is straight.
- Mark top support location. Disassemble the post and supports. Screw* top support into wall (see *figure 1*).
- Based on “Centerline Chart”, measure and mark locations of the other pair of supports, and then screw* supports into wall.

* Screws not included for top/bottom supports.

IMPORTANT NOTE: Depending on construction of wall, supports should be attached to wall studs, in-wall grounds (wall backing) of plywood or sheet metal, or solid part of brick or concrete wall with appropriate fasteners. Failure to use appropriate fasteners could result in collapse and personal injury. Eagle Group cannot be held responsible for failure of the device or any other devices due to improper installation. Also, it is your responsibility to make certain the mounting surface and method of mounting are suitable to support the anticipated weight which will be placed on this unit.

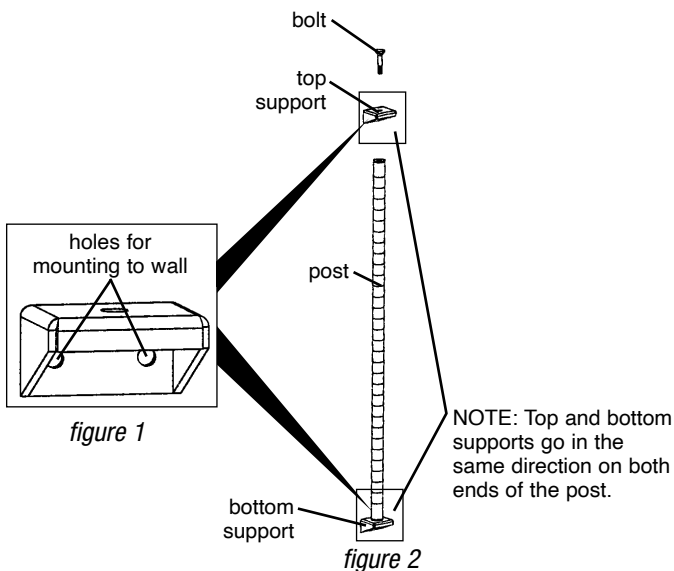

(continued on page 2)

Wall-Mounted Boat Racks

(Models #BRW4, BRW5, and BRW6 - continued)

ASSEMBLY INSTRUCTIONS

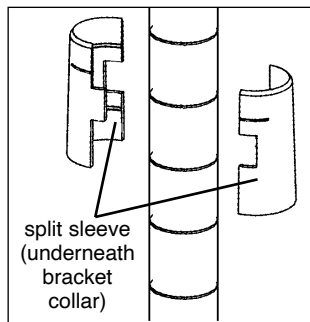

figure 3

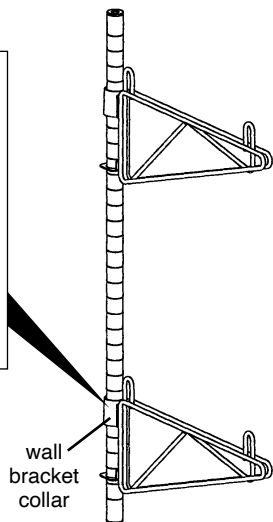

figure 4

3) Shelf Brackets

Note: Affix BOTTOM shelf bracket first.

- Snap plastic split sleeve onto post at desired shelf height (the wider part of the taper on the split sleeve is the bottom - see figure 3). Leave enough room at the bottom of the post for the wall bracket to hang.
- Slide wall bracket collar (see figure 4) over top of post and down onto plastic split sleeve. Repeat for top bracket.

Repeat this step for remaining post and brackets.

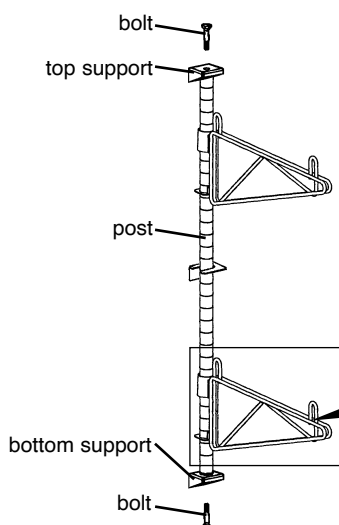

figure 5

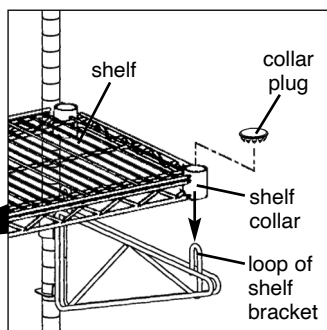

figure 6

4) Posts & Shelves

- Bolt the posts to the supports that are already attached to the wall (see figure 5).
- Lay shelf (shelves) on top of wall bracket(s), and cover shelf collar openings with collar plugs (see figure 6).

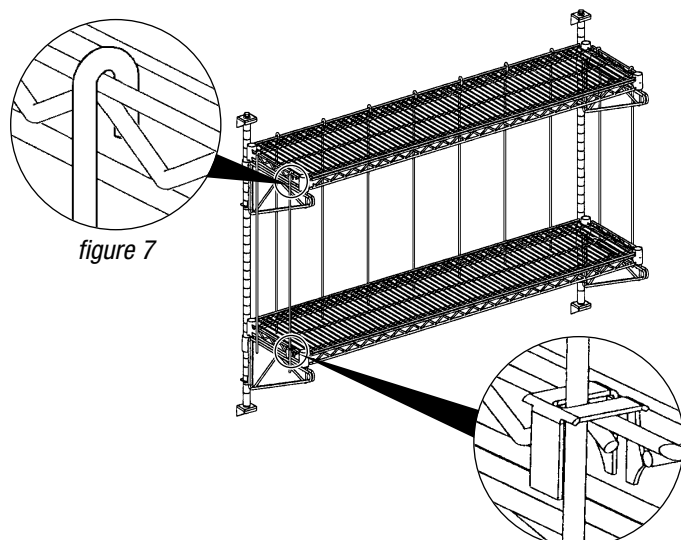

figure 7

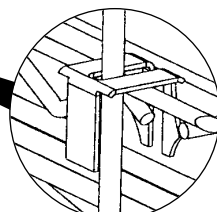

figure 8

5) Rods & Tabs

- Hook the rods where desired onto the outside of the top shelf (see figure 7).
- Clip the rods to the bottom shelf with the clips provided (see figure 8).

(End)

Wall-Mounted Boat Racks

(Models #BRW7 and BRW8)

ASSEMBLY INSTRUCTIONS

For models #BRW4, BRW5, and BRW6, see front page.

Parts List

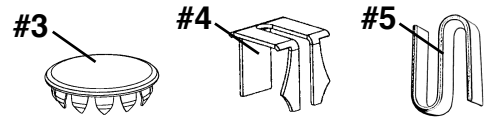
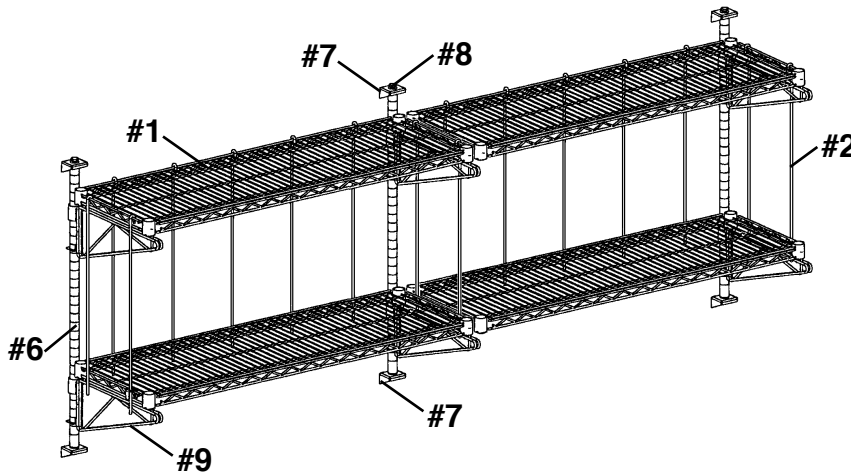

#	qty	part #	description
#1	4	*	wire shelf
#2	*	R26-C	rod & tie
#3	16	n/a	collar plug
#4	*	A204297	clip hold down for rods
#5	4	A200012	S-hooks
#6	3	PW33C**	33" posts
*Quantities and/or part numbers vary, depending on what is ordered.			
**Please note that the following parts are included with part #PW33C:			
#	qty	part #	description
#7	6	A217323	top/bottom support
#8	6	303999	bolt 3/8-16 x 1 1/4"
#9	6	PWB14C	post-wall bracket

Centerline Chart

Shelf Length	1st Centerline	2nd Centerline
84"	40 ⁷ / ₁₆ "	82 ³ / ₁₆ "
96"	46 ⁷ / ₁₆ "	94 ³ / ₁₆ "

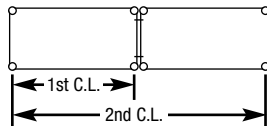

1) Center Lines

Refer to chart at left to determine proper centerline distances between top/bottom supports and shelf brackets.

2) Top & Bottom Supports

- Mark bottom support location at desired height (see *figure 1*) —using a level to insure support is level—and then screw* bottom support into wall.
- To determine top support location, bolt the post to the bottom support on the wall, then bolt the top support to the post (see *figure 2*). **IMPORTANT:** Use a level to insure post is straight.
- Mark top support location. Disassemble the post and supports. Screw* top support into wall (see *figure 1*).
- Based on “Centerline Chart”, measure and mark locations of other two pairs of top/bottom supports, and then screw* top/bottom supports into wall.

* Screws not included for top/bottom supports.

IMPORTANT NOTE: Depending on construction of wall, supports should be attached to wall studs, in-wall grounds (wall backing) of plywood or sheet metal, or solid part of brick or concrete wall with appropriate fasteners. Failure to use appropriate fasteners could result in collapse and personal injury. Eagle Group cannot be held responsible for failure of the device or any other devices due to improper installation. Also, it is your responsibility to make certain the mounting surface and method of mounting are suitable to support the anticipated weight which will be placed on this unit.

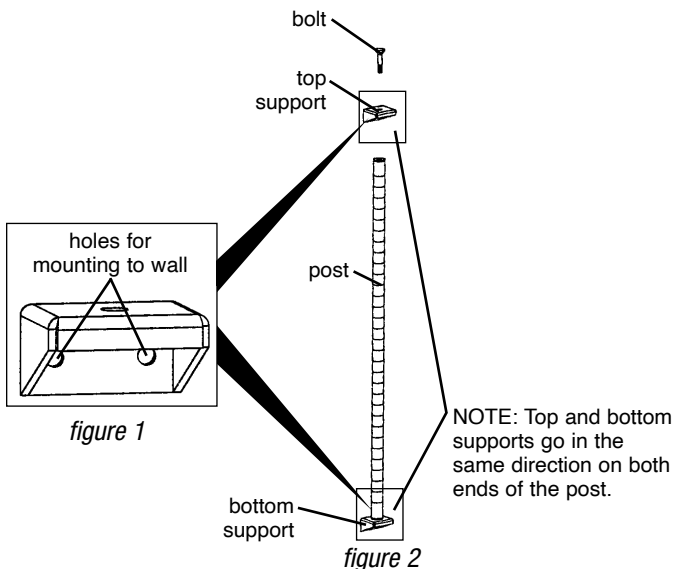

(continued on back page)

Wall-Mounted Boat Racks

(Models #BRW7 and BRW8 - continued)

ASSEMBLY INSTRUCTIONS

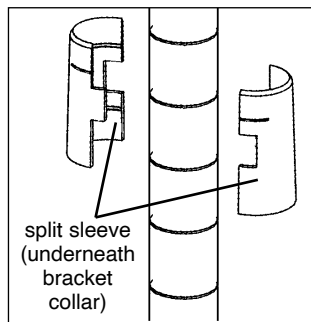

figure 3

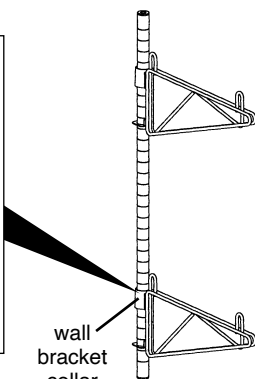

figure 4

3) Shelf Brackets

Note: Affix BOTTOM shelf bracket first.

- Snap plastic split sleeve onto post at desired shelf height (the wider part of the taper on the split sleeve is the bottom - see figure 3). Leave enough room at the bottom of the post for the wall bracket to hang.
- Slide wall bracket collar (see figure 4) over top of post and down onto plastic split sleeve. Repeat for top bracket.

Repeat this step for remaining posts and brackets.

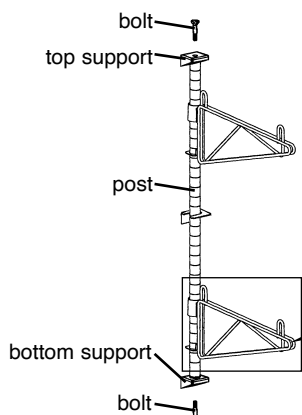

figure 5

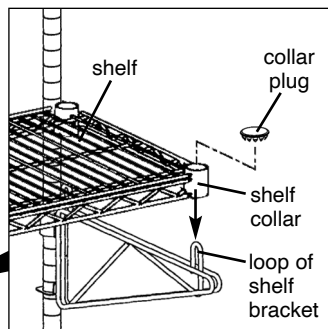

figure 6

4) Posts & Shelves

- Bolt the posts to the supports that are already attached to the wall (see figure 5).
- Lay each shelf on top of wall brackets, and cover shelf collar openings with collar plugs (see figure 6).

5) S-Hooks

- Hook two S-hooks onto the outside of the top shelf (see figure 7).
- Lay adjoining shelf inside S-hooks (see figure 7). Repeat this step for remaining shelf.

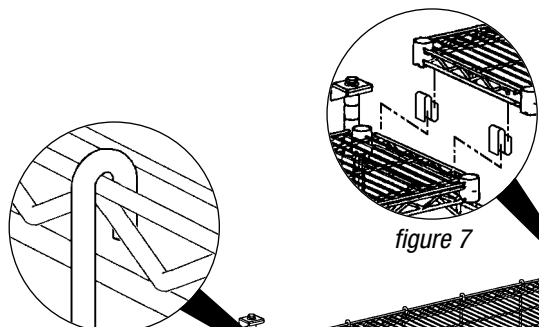

figure 7

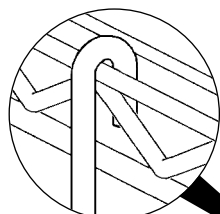

figure 8

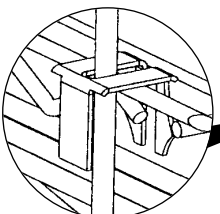

figure 9

6) Rods & Tabs

- Hook the rods where desired onto the outside of the top shelf (see figure 8).
- Clip the rods to the bottom shelf with the clips provided (see figure 9).

(End)

EAGLE
GROUP[®]
Profit from the Eagle Advantage[®]

• 100 Industrial Boulevard, Clayton, Delaware 19938-8903 U.S.A.
• Phone: 302/653-3000 • 800/441-8440
• Fax: 302/653-2065 • www.eaglegrp.com

Eagle Foodservice Equipment, Eagle MHC, and SpecFAB[®] are divisions of Eagle Group. ©2023 by the Eagle Group