

adjuTable® Work Surface System

ASSEMBLY INSTRUCTIONS

For adjuTable® with Cantilevered Overshelf System, see page 2.

For adjuTable® with Wire Overshelf System, see page 3.

CAUTION

INSPECT CONTENTS IMMEDIATELY AND FILE CLAIM WITH DELIVERING CARRIER FOR ANY DAMAGE. **SAVE YOUR BOX AND ALL PACKING MATERIALS.** YOU ARE RESPONSIBLE FOR DAMAGE TO YOUR UNIT IF RETURNED IMPROPERLY PACKED.

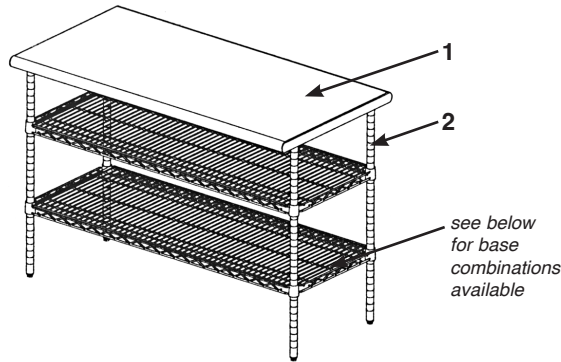

basic unit

Parts List

item #	qty	description
#1	1	tabletop
#2	4	33" post
#3	8	pair of split sleeves*

* Four pairs of split sleeves come with each C-frame, H-frame, and wire undershelf

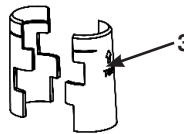

Base combinations available for adjuTable® Work Surface Systems

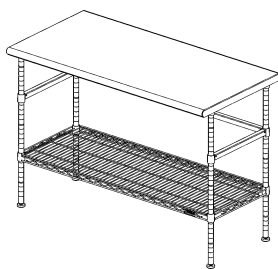

C-frame and wire undershelf

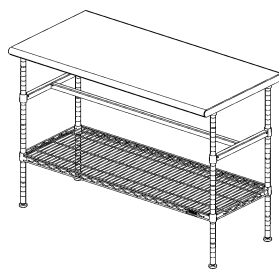

H-frame and wire undershelf

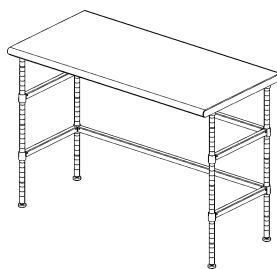

two C-frames

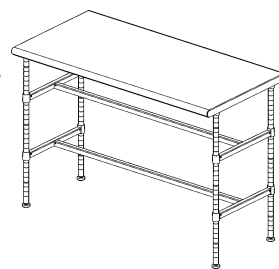

two H-frames

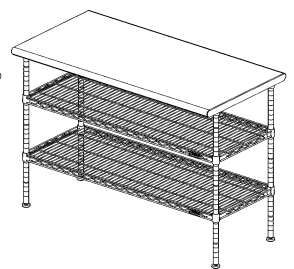

two wire undershelves

(continued on next page)

EG9958 Rev 04/24

adjustable® with Cantilevered Overshelf System

ASSEMBLY INSTRUCTIONS

For adjustable® without overshelves, see front page.
 For adjustable® with Wire Overshelf System, see page 3.

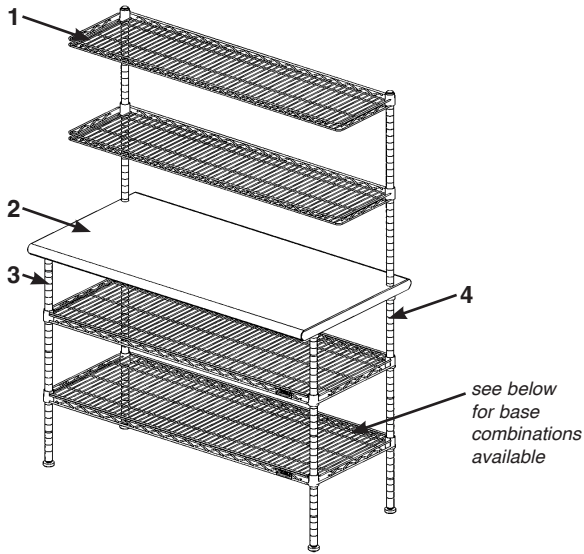

shown with two overshelves

Parts List

item #	qty	description
#1	1 or 2	cantilevered wire overshelf
#2	1	tabletop
#3	2	33" post
#4	2	54" post (for units with one overshelf), or 63" post (for units with two overshelves)
#5	10 or 12	pair of split sleeves*

* Four pairs of split sleeves come with each C-frame, H-frame, and wire undershelf. Two pairs come with each cantilevered overshelf.

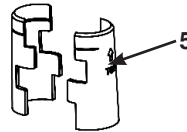

adjustable® Work Surface Systems with Cantilevered Overshelf System** shown with all available base combinations

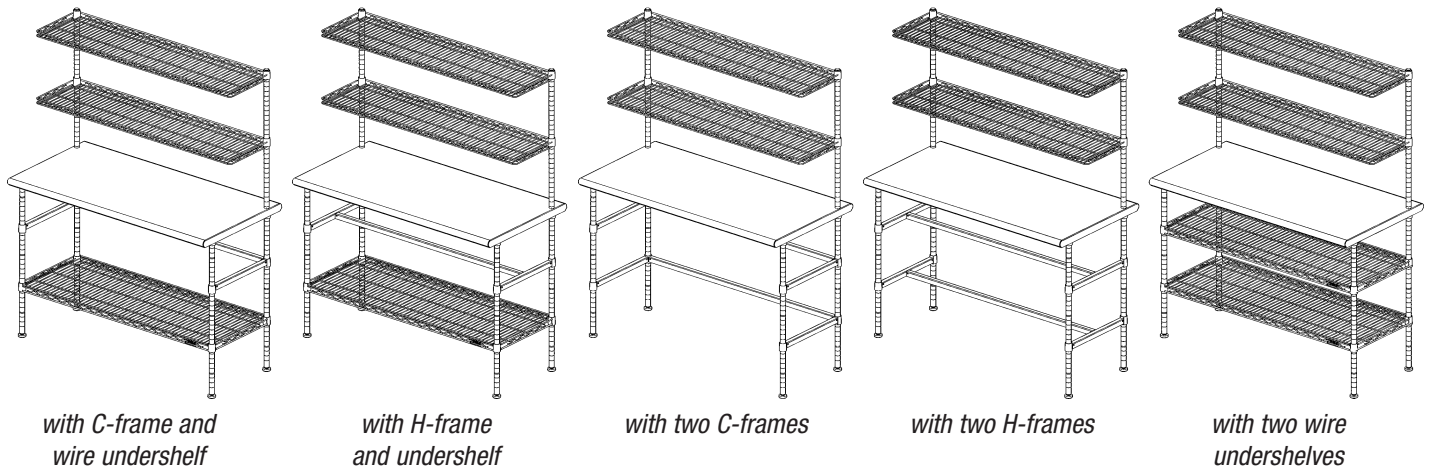

** Available with one or two cantilevered overshelves (shown with two overshelves)

(continued on next page) →

adjuSTable® with Wire Overshelf System

ASSEMBLY INSTRUCTIONS

For adjuSTable® without overshelves, see front page.
 For adjuSTable® with Cantilevered Overshelf System, see page 2.

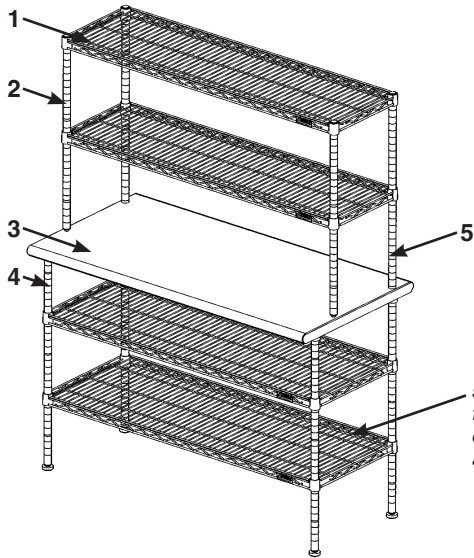

shown with two overshelves

Parts List

item #	qty	description
#1	1 or 2	cantilevered wire overshelf
#2	2	21" post (for units with one overshelf), or 29" post (for units with two overshelves)
#3	1	tabletop
#4	2	33" post
#5	2	54" post (for units with one overshelf), or 63" post (for units with two overshelves)
#6	12 or 16	pair of split sleeves*

* Four pairs of split sleeves come with each C-frame, H-frame, and wire undershelf. Four pairs come with each wire undershelf.

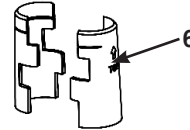

adjuSTable® Work Surface Systems with Wire Overshelf System** shown with all available base combinations

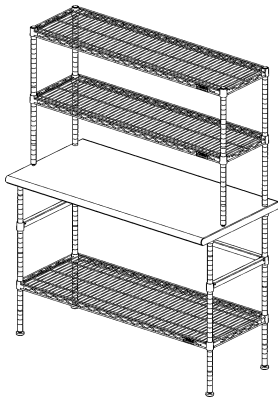

with C-frame and wire undershelf

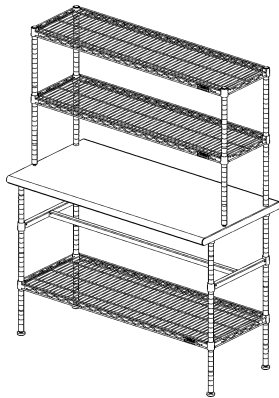

with H-frame and undershelf

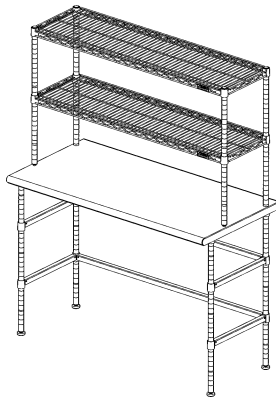

with two C-frames

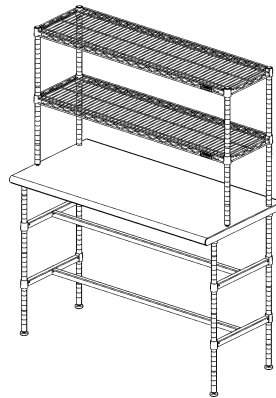

with two H-frames

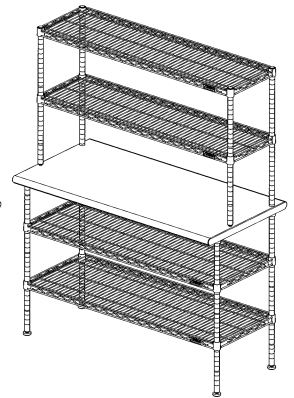

with two wire undershelves

** Available with one or two wire overshelves (shown with two overshelves)

(continued on next page) →

ASSEMBLY INSTRUCTIONS

Note: The instructions below show unit with two wire undershelves. Units with all other base configurations follow similar steps.

If you have casters, attach casters to posts now.

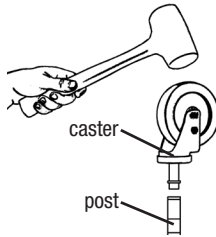

Insert caster into bottom of each post and drive in, using a mallet or hammer (see left).

Afterwards, go to **Step 1**.

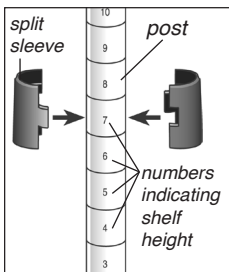

figure 1

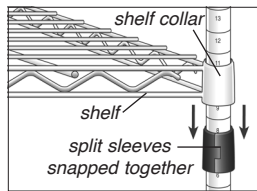

figure 2

1) Undershelves

- Referencing numbers on posts, snap plastic tapered split sleeves onto each post (for units with overshelves, two longest posts go in the back and two 33" in the front) at desired location of undershelf. The thicker part of the taper goes toward the bottom. Refer to *figures 1 and 2*. Make sure rib on split sleeve is seated into a groove on the post.
- Lower the shelf onto the posts until the plastic tapered split sleeves are snugly fitted within the shelf collars. Repeat this step for second undershelf. Refer to *figure 3*.

Note: The wider wire shelves are the undershelves. The narrow wire shelves are the overshelves.

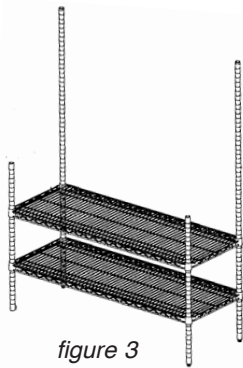

figure 3

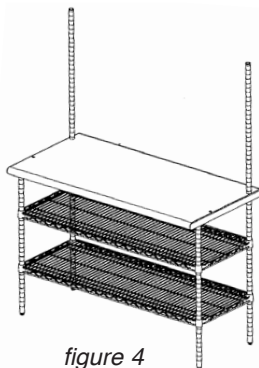

figure 4

2) Stainless Steel Tabletop

- Snap the plastic tapered split sleeves onto the very top of the shorter posts. Be sure that the plastic tapered split sleeves get snapped to the same groove on the longer posts.
- Lower the tabletop over the longer posts until the tabletop is seated snugly on the split sleeves. Refer to *figure 4*.

For units with overshelves, continue with **Steps 3 and 4**.

3) Posts for Units with Wire Overshelves

Note: For units with Cantilevered Overshelf, skip to **Step 4**.

Bolt the two 21" (for 1-tier units) or 29" posts (for 2-tier) onto the tabletop. One end of these posts has a nut welded in it. This is the end for the bolt. Refer to *figure 5a*.

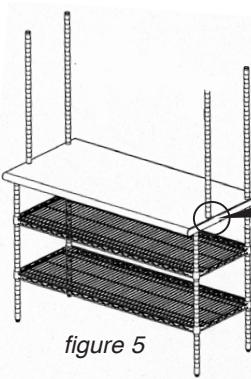

figure 5

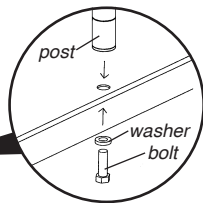

figure 5a

4) Overshelves (Wire and Cantilevered)

Note: If 2-tier unit, install the bottom overshelf first. Wire overshelves shown.

- Referencing numbers on posts, snap plastic tapered split sleeves onto each post at desired location of overshelf. The thicker part of the taper goes toward the bottom. Make sure rib on split sleeve is seated into a groove on the post.
- Lower the overshelf onto the posts until the plastic tapered split sleeves are snugly fitted within the shelf collars.
- Repeat this step for top overshelf (if 2-tier unit). Refer to *figure 6*.

5) Seat Shelves

Securely seat all shelves by lightly tapping with a rubber mallet to secure shelving to split sleeve and post.

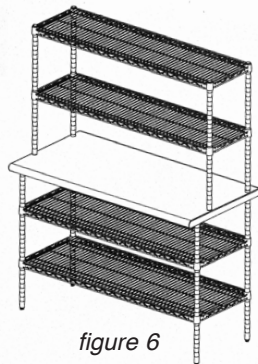

figure 6

(End)