

Shelving Display Rack with Quad-Adjust® Shelves

ASSEMBLY INSTRUCTIONS

CAUTION

INSPECT CONTENTS IMMEDIATELY AND FILE CLAIM WITH DELIVERING CARRIER FOR ANY DAMAGE. **SAVE YOUR BOX AND ALL PACKING MATERIALS.** YOU ARE RESPONSIBLE FOR DAMAGE TO YOUR UNIT IF RETURNED IMPROPERLY PACKED.

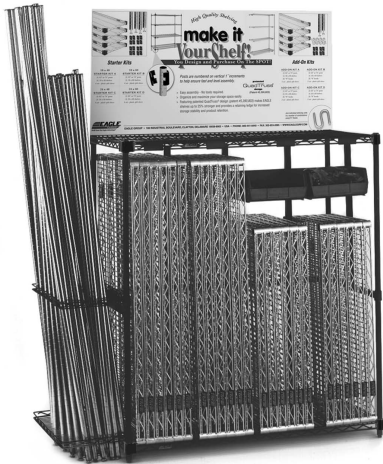

Parts List

qty	part #	description
2	P54-BL	54" Black Posts (front)
2	P74-BL	74" Black Posts (rear)
1	315192	Literature Holder
3	315036	Long Vertical Divider
1	315037	Short Vertical Divider
1	315040	3-Sided Channel Frame
1	315212	Bin Holder
1	315046	Sign
2	315218	Velcro
6	A206216	Shelf Markers
4	300794	Sheet Metal Screws #8
2	A206271	Cantilever Shelves
1	300757	Machine Screw 10-24
2	QA2448BL	Black Epoxy Shelves

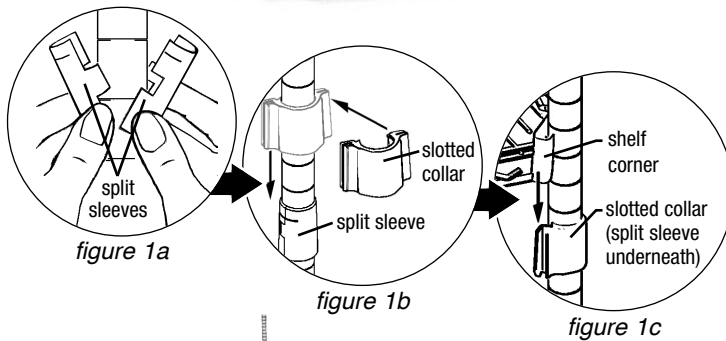

Step 1 - Mount bottom shelf to #3 groove on posts.

- Snap split sleeves onto all posts. The wider part of the taper goes toward the bottom. Make sure rib inside split sleeve is seated into a groove on the post (see *figure 1a*).
- Attach Quad-Adjust® slotted collar onto the split sleeves (see *figure 1b*).
- Slide shelf corners into slotted collars (see *figure 1c*).

Step 2 - Mount bottom cantilevered shelf to #5 groove on left-side posts.

- Snap split sleeves onto front & rear posts at left-hand side of unit.
- Slide shelf down posts and onto split sleeves (see *figure 2*).

Step 3 - Mount 3-sided channel frame to #25 groove on posts.

- Snap split sleeves onto all posts.
- Note the orientation of channel frame in *figure 3*, and slide frame down posts and onto split sleeves.

Step 4 - Mount top cantilevered shelf to #27 groove on left-side posts.

- Snap split sleeves onto posts at the left-hand side of unit.
- Slide shelf down posts and onto split sleeves (see *figure 4*).

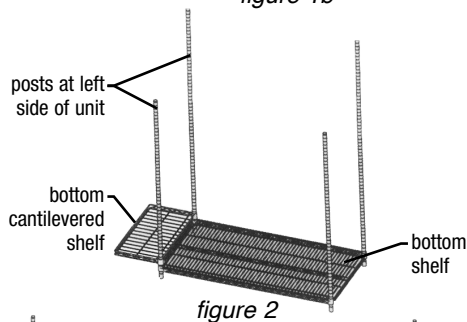

figure 2

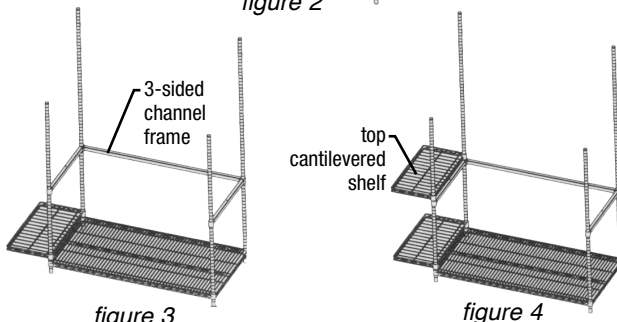

figure 3

figure 4

(continued on page 2)

EG9955 Revised 01/24

Shelving Display Rack with Quad-Adjust® Shelves

ASSEMBLY INSTRUCTIONS

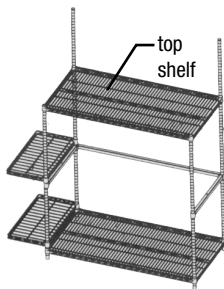

figure 5

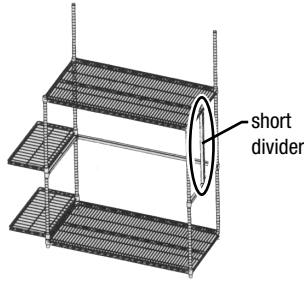

figure 6

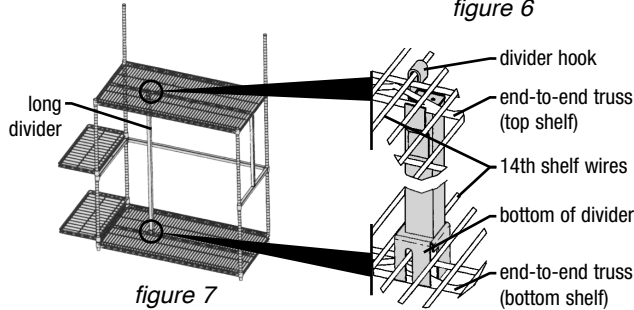

figure 7

figure 7a

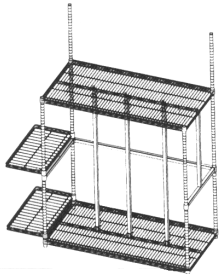

figure 8

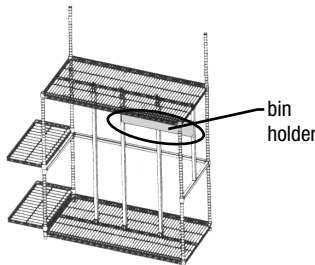

figure 9

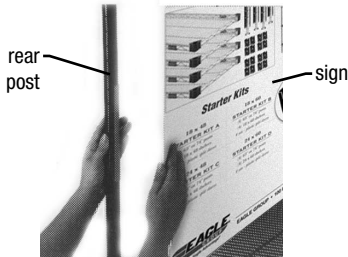

figure 10

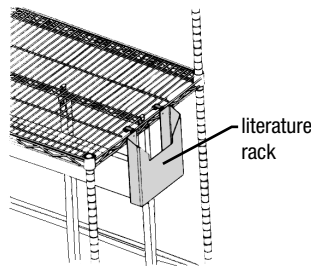

figure 11

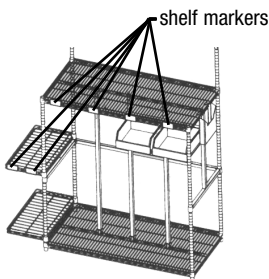

figure 12

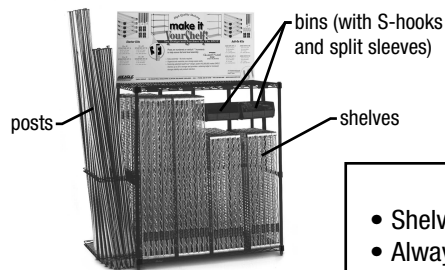

figure 13

Step 5 - Mount top shelf to #53 groove on rear posts (top groove on front posts).

- Snap split sleeves onto all posts.
- Attach Quad-Adjust® slotted collar onto the split sleeves.
- Slide shelf into slotted collars (see figure 5).

Step 6 - Attach short vertical divider.

- Assemble short divider to top shelf at right-hand side of unit (see figure 6).
- Bolt divider to 3-sided frame as shown in figure 6.

Step 7 - Attach long vertical dividers.

- Hook divider onto the 14th shelf wire from the left end. Divider hook must capture the middle end-to-end truss to ensure no front-to-back movement.
- Bottom of divider is to fit between shelf wires and truss. See figures 7 and 7a.

Step 8 - Attach remaining long vertical dividers.

- Repeat Step 7, assembling one of the two remaining dividers 12 wires from the first divider.
- Assemble the last divider 14 wires from the second divider. See figures 7a and 8.

Step 9 - Attach the bin holder to the long and short dividers.

- Screw the bin holder with the 90° flanges toward the bottom (see figure 9).
- Level unit.

Step 10 - Attach the sign to the rear posts.

- Attach velcro strips to front side of the rear posts and to back side of the sign, where strips will connect with velcro attached to posts.
- Hang the sign (see figure 10).

Step 11 - Hang literature rack onto top shelf.

- Hang rack, centered on right-hand end (see figure 11).

Step 12 - Attach shelf markers.

- Six (6) included. See figure 12.

Step 13 - Load shelves, posts, bins, S-hooks, and split sleeves, onto rack.

- See figure 13.

(End)

IMPORTANT NOTES:

- Shelves must be placed on a solid floor capable of supporting the load.
- Always be sure display rack is properly leveled.
- Never overload display rack.
- Do not drop heavy objects onto shelves.