

# Adjustable Slides

## ASSEMBLY INSTRUCTIONS

### CAUTION

INSPECT CONTENTS IMMEDIATELY AND FILE CLAIM WITH DELIVERING CARRIER FOR ANY DAMAGE. **SAVE YOUR BOX AND ALL PACKING MATERIALS.** YOU ARE RESPONSIBLE FOR DAMAGE TO YOUR UNIT IF RETURNED IMPROPERLY PACKED.

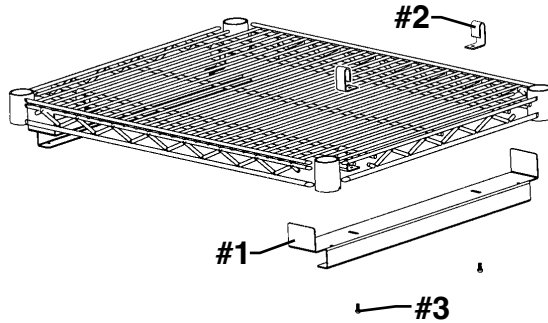

### Parts List

Item #	qty	part number	description
1 *	2	A200120	18" slide
		or A200121	21" slide
		or A200122	24" slide
		or A209958	30" slide
2	4	clip	A200114
3	4	screw	200756

\* Part number of slides vary, depending on order.

### Before assembly, determine where the clips will be located on the shelf:

- Hold slides together with adjoining drawer or tote box and place under wire shelf.
- Note locations of holes on slides. These holes will be the location of the clips.
- Set aside drawer/tote box and slides until later.

### Step 1 - Attach clips to shelf (two clips per slide).

Hang clips on wires running left-to-right (not front-to-back).

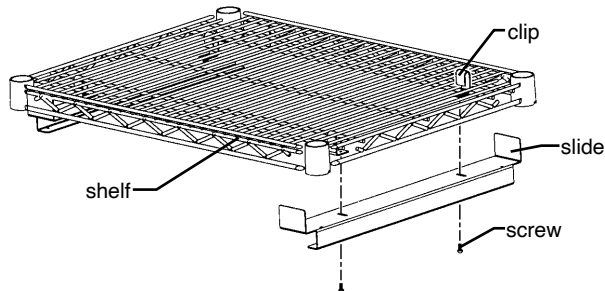

### Step 2 - Attach slides to shelf.

Hold slides under shelf and fasten to clip with slotted screws.

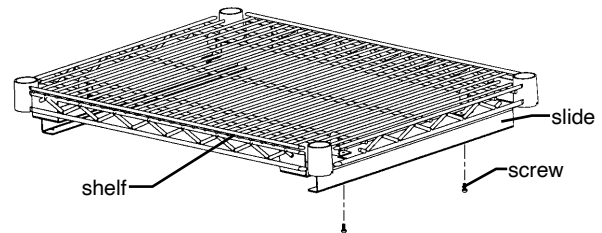

### Step 3 - Slide drawer or tote box into slides.

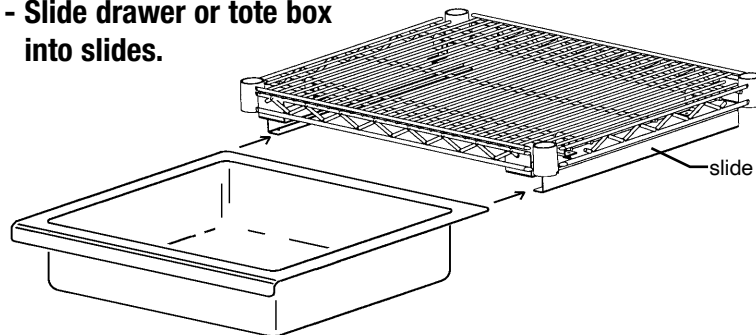

(End)

EG9953 Revised 01/24