

Gas Fryer (LPG Unit)

INSTRUCTION
SHEET
#383291

INSTALLATION OPERATING & MAINTENANCE INSTRUCTIONS

CAUTION

INSPECT CONTENTS IMMEDIATELY AND FILE CLAIM WITH DELIVERING CARRIER FOR ANY DAMAGE.
SAVE YOUR BOX AND ALL PACKING MATERIALS.
YOU ARE RESPONSIBLE FOR DAMAGE TO YOUR UNIT IF RETURNED IMPROPERLY PACKED.

Model: CLGF30-LP



IMPORTANT FOR FUTURE REFERENCE

Please complete this information and retain this manual for the life of the equipment. For Warranty Service and/or parts, this information is required.

CLGF30-LP

Model Number

Serial Number

Date Purchased

FOR YOUR SAFETY: Do not store or use gasoline or other flammable vapors or liquids in the vicinity of this or any other appliance.



MESURE DE SÉCURITÉ: Ne pas entreposer ni utiliser d'essence ni autres vapeurs ou liquides inflammables à proximité de cet appareil ou de tout autre appareil.



WARNING: Improper installation, adjustment, alteration, service or maintenance can cause property damage, injury or death. Read the installation, operating and maintenance instructions thoroughly before installing or servicing this equipment.



AVERTISSEMENT: L'installation, le réglage, la modification, la réparation ou l'entretien incorrects de cet appareil peuvent causer des dommages matériels, des blessures ou la mort. Lire attentivement les instructions d'installation, de fonctionnement et d'entretien avant de procéder à son installation ou entretien.



WARNING: Instructions must be posted in a prominent location. All safety precautions must be taken in the event the user smells gas. Safety information can be obtained from your local gas supplier.



AVERTISSEMENT: Les instructions doivent être affichées dans un endroit très visible. Toutes les mesures de sécurité doivent être prises au cas où l'utilisateur sente l'odeur de gaz. L'information de sécurité peut être obtenue de votre fournisseur local de gaz.



CAUTION: These models are designed, built, and sold for commercial use only. If these models are positioned so the general public can use the equipment, make sure that cautions, warnings, and operating instructions are clearly posted near each unit so that anyone using the equipment will use it correctly and not injure themselves or harm the equipment.



ATTENTION: Ces modèles sont conçus, fabriqués, et vendus pour un usage commercial seulement. Si ces modèles sont placés pour que le grand public puisse les utiliser, assurez-vous que les consignes d'attention, d'avertissement, et les instructions d'utilisation soient clairement affichées près de chaque unité de sorte que n'importe quel utilisateur de l'appareil l'emploie correctement et ne se blesse pas ou n'endommage pas l'appareil.



(continued on next page) 

EG9936 Revised 10/22



- 100 Industrial Boulevard, Clayton, Delaware 19938-8903 U.S.A.
- Phone: 302/653-3000 • 800/441-8440 • Fax: 302/653-2065
- www.eaglegrp.com • www.eaglegrpnews.com • www.eaglemhc.com

Eagle Foodservice Equipment, Eagle MHC, and SpecFAB® are divisions of Eagle Group. ©2022 by the Eagle Group

Gas Fryer (LPG Unit)

INSTALLATION OPERATING & MAINTENANCE INSTRUCTIONS

GAS PRESSURE

The appliance and its individual shutoff valve (to be supplied by user) must be disconnected from the gas supply piping system during any pressure testing of that system at test pressures in excess of ½ psi (3.45 kPa).

The appliance must be isolated from the gas supply piping system by closing its individual manual shut-off valve during any pressure testing of the gas supply piping system at test pressures equal to or less than ½ psi (3.45 kPa).

PRESSION DE GAZ

L'appareil et sa valve d'arrêt individuelle (doit être fournie par l'utilisateur) doivent être déconnectés de la canalisation de gaz durant tout test de pression du système à une pression supérieure à ½ psi (3.45 kPa).

L'appareil doit être isolé du système de canalisation de gaz par la fermeture de la valve individuelle d'arrêt manuel pendant tout test de pression du système de canalisation de gaz à pression de test égale ou inférieure à ½ psi (3.45 kPa).

WARNING: A factory authorized agent should handle all maintenance and repair. Before doing any maintenance or repair, contact EAGLE GROUP.



AVERTISSEMENT: Un technicien autorisé par l'usine devra effectuer tout l'entretien et les réparations. Avant de faire tout entretien ou réparation, veuillez contacter EAGLE GROUP.



Congratulations on your purchase of this commercial cooking equipment. Eagle Group takes pride in the design and quality of our products. When used as intended and with proper care and maintenance, you will experience years of reliable operation from this equipment. To ensure best results, it is important that you read and follow the instructions in this manual carefully.

TABLE OF CONTENTS

ITEM	PAGE
Safety precautions	3
General Installation Instructions	4
Specifications & Dimensions.....	4
Lighting Instructions.....	5
Operating Instructions	6
Cleaning & Maintenance.....	7-8
Troubleshooting.....	9
Exploded View	10
Replacement Parts List.....	10
Baffle Plate Installation Instructions.....	11
Warranty	back page

(continued on next page) 

Gas Fryer (LPG Unit)

INSTALLATION OPERATING & MAINTENANCE INSTRUCTIONS

LOCATION OF DATA PLATE

The data plate is located on the side panel.

IMMEDIATELY INSPECT FOR SHIPPING DAMAGE

All containers should be examined for damage before and during unloading. The freight carrier has assumed responsibility for its safe transit and delivery. If equipment is received damaged, either apparent or concealed, a claim must be made with the delivering carrier.

A) Apparent damage or loss must be noted on the freight bill at the time of delivery. It must then be signed by the carrier representative (Driver). If this is not done, the carrier may refuse the claim. The carrier can supply the necessary forms.

B) Concealed damage or loss if not apparent until after equipment is uncrated, a request for inspection must be made to the carrier within 15 days. The carrier should arrange an inspection. Be certain to hold all contents and packaging material.

Installation and should be performed by a qualified installer who thoroughly read, understands and follows these instruction.

If you have questions concerning the installation, operation, maintenance or service of this product, contact the factory.

SAFETY PRECAUTIONS



DANGER: This symbol warns of imminent hazard which will result in serious injury or death.

DANGER: Ce symbole avertit d'un risque imminent qui a comme conséquence des blessures graves ou la mort.



WARNING: This symbol refers to a potential hazard or unsafe practice, which could result in serious injury or death.

AVERTISSEMENT: Ce symbole désigne un possible danger ou une pratique dangereuse qui pourrait entraîner des blessures graves, ou la mort.



CAUTION: This symbol refers to a potential hazard or unsafe practice, which could result in minor or moderate injury or product or property damage.

ATTENTION: Ce symbole désigne un possible risque ou une pratique dangereuse, qui pourrait avoir comme conséquence des blessures, ou des dommages mineurs ou modérés au produit ou au matériel.



NOTICE: This symbol refers to information that needs special attention or must be fully understood even though not dangerous.

AVIS: Ce symbole désigne l'information qui a besoin d'une attention particulière ou qui doit être entièrement comprise bien que non dangereuse.



NOTICE: This product is intended for commercial use only. Not for household use.

AVIS: Ce produit est prévu pour un usage commercial seulement. Ce produit n'est pas destiné à un usage domestique.



NOTICE: Local codes regarding installation vary greatly from one area to another. The National Fire Protection Association, Inc., states in its NFPA96 latest edition that local codes are "Authority Having Jurisdiction" when it comes to requirement for installation of equipment. Therefore, installation should comply with all local codes.

AVIS: Les codes locaux concernant l'installation changent considérablement d'un secteur à l'autre. National Fire Protection Association, Inc., déclare dans sa dernière édition NFPA96 que les codes locaux sont "Autorité ayant la juridiction" quand il s'agit des conditions pour l'installation d'appareils. Par conséquent, l'installation doit être conforme à tous les codes locaux.



(continued on next page) 

Gas Fryer (LPG Unit)

INSTALLATION OPERATING & MAINTENANCE INSTRUCTIONS

GENERAL INSTALLATION INSTRUCTIONS

Unit installation must conform to the National Fuel Gas Code, ANSI Z223.1/NFPA 54, the National Gas Installation Code, CSA-B149.1, or the Propane Installation Code, CSA-B149.2 as applicable and in accordance with local codes.

1. Ensure gas supply and gas type as shown on unit nameplate are the same.
2. Screw legs into the permanently fastened nuts on the four corners of the unit and tighten by hand. Level the unit by turning the adjustment screw at the bottom of each leg. Do not slide unit with legs mounted, lift if necessary to move unit.
3. Install shut-off valve (not supplied) and regulator to gas inlet. Use proper pipe thread compound. Pipe threading compound must be resistant to the action of liquefied petroleum gases.
4. Install baffle plate in flue - see figure 1.

CAUTION: DO NOT use an open flame to check for leaks. Check all gas piping for leaks with a soap and water solution before operating unit.



ATTENTION: NE JAMAIS employer une flamme nue pour déceler l'existence de fuites. Examinez toute la tuyauterie de gaz pour déceler les fuites avec une solution de savon et d'eau avant de mettre en marche l'unité.



ONLY NON-COMBUSTIBLE MATERIALS CAN BE USED IN CLOSE PROXIMITY TO THIS APPLIANCE.

Combustible clearances:

6" sides (152mm); 6" rear (152mm); 4" floor (102mm)

Non-combustible clearances:

0" sides (0mm); 0" rear (0mm); 4" floor (102mm)

Do not obstruct the flow of combustion and ventilation air, under the unit by the legs or behind the unit by the flue.

Ne pas obstruer le flux d'entrée et de sortie d'air de combustion et de ventilation, sous l'unité par les pattes ou derrière l'appareil par le conduit.

Adequate clearance for air openings into the combustion chamber is required. Do not place objects between the bottom of the unit and the counter top.

Un espace adéquat pour les orifices d'aération dans la chambre de combustion est nécessaire. Ne placez pas des objets entre le fond de l'unité et le comptoir supérieur.

There must be adequate clearance for removal of the front panel. All major parts except the burners are removable thru the front if the gas line is disconnected.

SPECIFICATION AND DIMENSIONS

Model #	Width (Inches)	Depth (Inches)	Height (Inches)	Total Input (BTU)	Input Gas pressure (in.w.c)	Working Pressure (in.w.c)
CLGF30-LP	16-7/8	31-1/8	26	53,000	10	10

(continued on next page) 

Gas Fryer (LPG Unit)

INSTALLATION OPERATING & MAINTENANCE INSTRUCTIONS

LIGHTING INSTRUCTIONS

Fryers are furnished with a Gas Control Safety Valve. Please follow the instructions below.

Before Lighting Pilot and Burners

Fill the fat tank about 3/4" below the full line with proper frying compound before lighting pilot. The reason for filling the tank 3/4" below the full line is that the frying compound will expand during the preheating process.

If the frying compound expands above the full line, the frying compound may overflow out of the tank during the cooking process. The reason for adding fry compound in fry tank before lighting the pilot or burners is that the unit will be damaged if this is not done.

Operating Instruction:

Step 1. Ensure this Gas Control Valve dial is at the "OFF" position.



Step 2. Ensure the thermostat dial is at the "OFF" position.



Step 3. Turn the Gas Control Valve dial to "Pilot" position and press and hold. Press the pilot ignition button. If the unit does not light, continue pressing and holding the pilot button and press the ignition button again. Purging air from the system may take 5-7 minutes on first use.

(continued on next page) 

Gas Fryer (LPG Unit)



INSTALLATION OPERATING & MAINTENANCE INSTRUCTIONS

Step 4. Turn the Gas Control Valve dial to the "ON" position and using the thermostat dial, set the desired temperature. You can monitor the flame status through this panel



Instruction for draining oil

A drain extension pipe has been provided attached to the inside of the main door. Screw the drain extension pipe into the main drain valve. Once secured, use the blue handle; turn the valve on to release the oil.

 **CAUTION:** 

The fryer must be turned completely off prior to draining the oil. Ensure the thermostat and gas control valve are in the off position and the pilot and burners are completely extinguished.



OPERATING INSTRUCTIONS

All burners are lit from constantly burning pilots. Turning the thermostat to the desired temperature is all that is required to put the unit in service.

Do not permit fans to blow directly at the unit. Wherever possible, avoid open windows next to the unit's sides or back. Avoid wall type fans which create air cross-currents within a room. It is also necessary that sufficient air should be allowed to enter the room to compensate for the amount of air removed by any ventilating system. Otherwise, a subnormal atmospheric pressure will occur, which will effect operation and cause undesirable working conditions.

A properly designed and installed hood will act as the heart of the ventilating system for the room or area in which the unit is installed and will leave the unit independent of changing draft conditions.

All valves and thermostats must be checked periodically. Consult the authorized service representative in your area.

A planned maintenance program can ensure the safety and performance of this unit is maintained.

(continued on next page) 

Gas Fryer (LPG Unit)

INSTALLATION OPERATING & MAINTENANCE INSTRUCTIONS

CLEANING

Initial Cleaning

Always clean equipment thoroughly before first use. Clean the protective oil from the bright parts and interior of tank with an appropriate de-greasing solution.

Daily Cleaning

1. Always turn unit off and allow it to cool completely before cleaning.
2. Never clean unit by immersing it in water.
3. The frequency of cleaning should depend on the load conditions. Set a definite cleaning schedule corresponding to how hard the kettle is used. Cleaning should be done at a least once a week.
4. Strain the frying compound into a clean container. Make sure there is no compound left in tank. (If the tank is left empty for more than 2 minutes, shut the pilot off. If this is not done, the tank may be damaged.)
5. Add water to the "MAX" line.
6. Add any good grade of cleaner following cleaner instructions.
7. Turn the thermostat to 75°F (dial "°F" position). Let the heating unit bring the solution to a boil.
8. Boil long enough to loosen or dissolve all varnish or carbon deposits. This should take approximately 30 minutes.
9. Turn the unit off. Make sure pilot is turned off at this time.
10. If necessary, clean the thermostat probes using a long-handled fiber or plastic brush and mild soap solution.
11. Rinse with clean water to remove all cleaning mixture.
12. Rinse the inside of the tank with 2 cups of vinegar.
13. Rinse with clean water until the vinegar odor is gone. The fry tank must be thoroughly rinsed since even a trace of cleaner left inside the tank will contaminate the fry compound.
14. Dry thoroughly.
15. Cover the tank if compound will not be added until a future date.
16. Clean all exterior surfaces of unit on a regular basis with a damp cloth. Thin films of oil subjected to frying temperatures quickly form into gummy consistency. In order to avoid these gum formations, clean the surfaces on a regular basis.
17. To remove discolorations or oil film, a non-abrasive cleaner may be used.

CAUTION: Clean exterior of regulator at least once a month. Make sure the vent opening is open and not blocked in any way. Failure to do so will cause variations in pressure. Your unit will not function as well and it could shorten the life of the product.



ATTENTION: Nettoyer l'extérieur du régulateur au moins une fois par mois. Assurez-vous que l'orifice de ventilation est ouvert et n'est pas obstrué de quelque façon que ce soit. Le non-respect de cette précaution causera des variations dans la pression. Votre unité ne fonctionnera pas comme elle devrait et cela pourrait raccourcir la vie du produit.



(continued on next page) 

Gas Fryer (LPG Unit)

INSTALLATION OPERATING & MAINTENANCE INSTRUCTIONS

MAINTENANCE

OVERNIGHT SHUTDOWN

Turn the temperature control knob to the off position. (The pilot flame alone will keep the frying compound temperature to 130-145°F(54.5-62.8°C). when not under any load. This will shorten preheat time when turned back on.)

EXTENDED SHUTDOWN (4 DAYS OR LONGER)

1. Turn the temperature control knob to the off position.
2. Turn the Off/Pilot/On valve control knob to the off position.
3. Turn the manual control valve under the unit to the off position.
4. Turn the supply valve to the off position (not supplied).
5. The entire flue duct opening on the top rear of unit must always be left uncovered.

Filling Fry Tank (CAUTION: NEVER LIGHT PILOT OR TURN BURNERS ON WITH EMPTY TANK)

1. Fill the fry tank approximately 3/4" below the full line. The fry compound will expand as it is heated. Heat the fry compound to 375° F(190°C) for 20 minutes then check the level. Add or decrease amount of fry compound so it lines up with the full line.
2. When using solid frying compound, put enough compound in fry tank so at least half or more of the tank has compound in it. Then set the temperature to 200 ° F(93.3°C) on dial and allow the compound to liquefy. Add to adjust compound level.
3. Use a quality frying compound.
4. Filter the frying compound frequently, at least once a day.
5. Skim out food particles frequently with a strainer/skimmer.
6. Add at least 15% (of fry tank capacity) of fresh frying compound daily (more if possible) without overloading tank. If 15% of frying compound is not used daily, remove some of the compound for other use (gravy, griddle frying, etc.) to permit adding 15% of fresh compound daily.
7. Do not overload the fry baskets. Overloading will result in longer recovery time, longer cook time, and compound absorption into the product.
8. Prepare the food properly.
9. Keep salt out of the frying compound. Do not salt foods with the basket above the kettle.
10. Ensure a good thermostat operation by checking frying compound temperature with a reliable frying thermometer. Temperature of compound should be comparable to thermostat setting.
11. Keep the fry tank and thermo-probes clean.

Thermostat Calibration

The fryer control is factory calibrated. If cooking results indicate unit is not maintaining correct temperatures, consult an authorized service representative.

SERVICE / REPAIR

NOTE: THIS APPLIANCE MUST ONLY BE SERVICED BY AN AUTHORIZED AGENT.

NOTE: Parts protected by the manufacturer or his agent are not to be adjusted by the installer, unless the installer is an authorized service agent.

If you have any questions or problems, contact your nearest Service Representative.

(continued on next page) 

Gas Fryer (LPG Unit)

INSTALLATION OPERATING & MAINTENANCE INSTRUCTIONS

TROUBLESHOOTING GUIDE PROBLEM	POSSIBLE CAUSE							
	Frying Temperature Too High/Overheating (Check Thermostat)	Frying Temperature Too Low/Overheating (Check Thermostat)	Over loading Fryer	Improper Draining of Food After Frying	High Moisture Content in Food Being Fried	Inadequate Frying Compound Turnover	Improper Preparation of Food	Contamination of Fryer Compound (Due to salt or other foreign material)
Excessive & Premature Foaming	★		★			★		★
Greasy Food / Excessive Frying Compound Absorption		★	★	★	★	★	★	
Objectionable Odor or Flavor of Frying Compound					★	★		★
Objectionable Flavor of Fried Food				★		★	★	
Excessive Smoking of Frying Compound	★					★	★	★
Excessive Darkening of Frying Compound	★					★	★	★
Frying Compound Won't Hold Heat		★	★		★		★	
Food Crust Color Not Brown		★	★		★		★	
Rapid Breakdown of Frying Compound	★				★		★	★

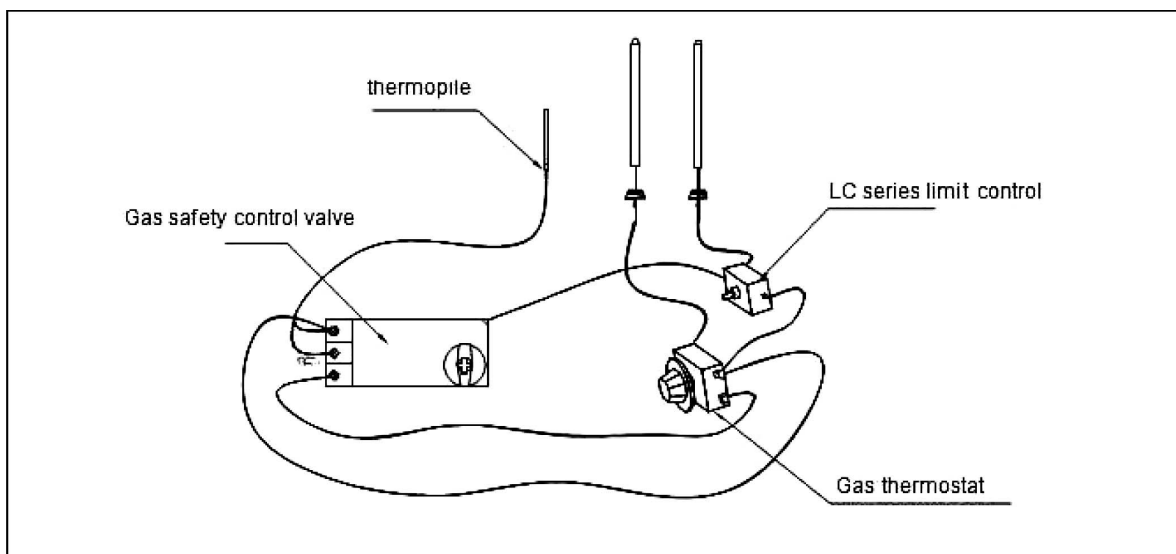

(continued on next page)

Gas Fryer (LPG Unit)

INSTALLATION OPERATING & MAINTENANCE INSTRUCTIONS

MODEL: CLGF30-LP

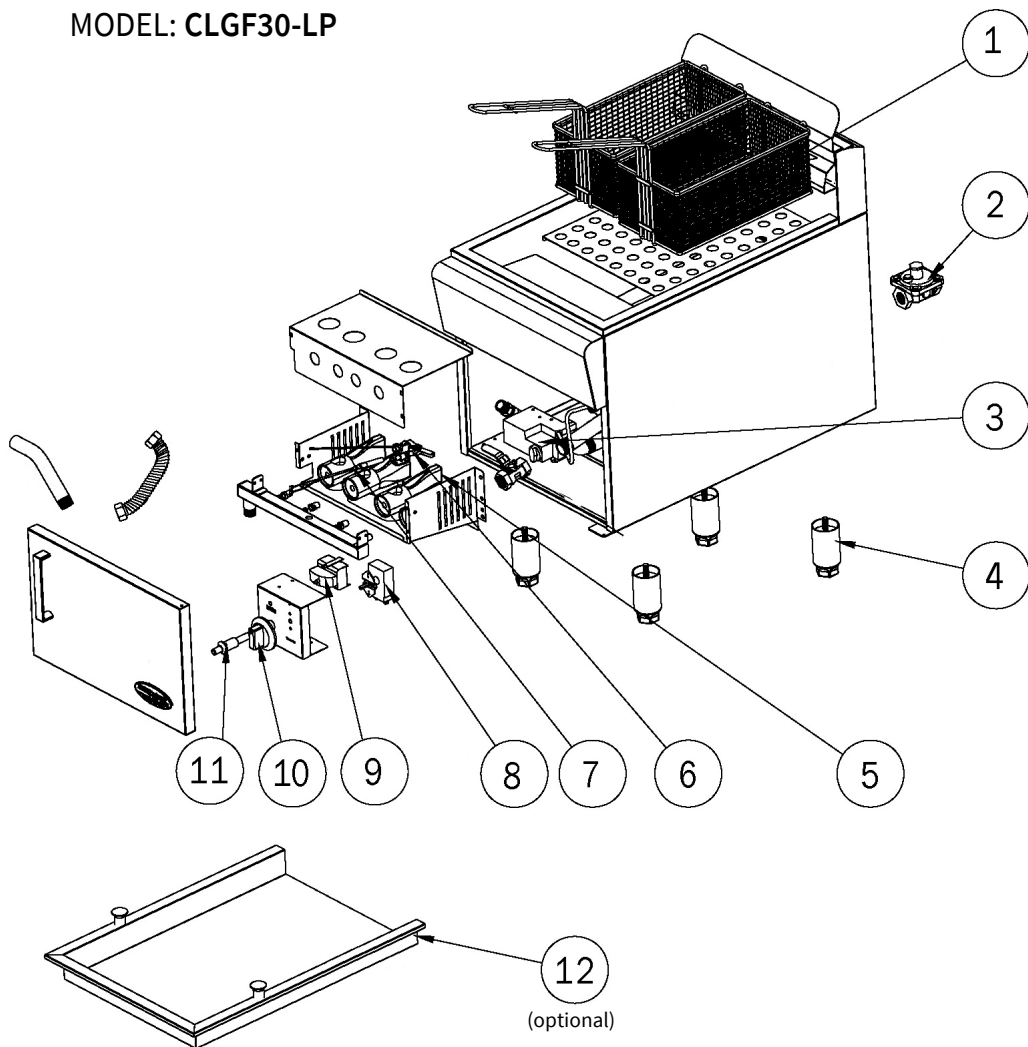

REPLACEMENT PARTS LIST

NO.	DESCRIPTION	PART #		QTY
		(2021 and older)	(2022 and newer)	
1	Basket	381096	381096	2
2	Regulator	381097	381097	1
3	Gas Safety Control Valve	381098	381098	1
4	Foot	381100	381100	4
5	Burner	381101	381101	4
6	Flame Device System	381102	381102	1
7	Thermopile	381104	381104	1
8	Gas Thermostat	381105	390737	1
9	LC Series Limit Control	381106	390738	1
10	Replacement Thermostat Knob	388363	390739	1
11	Piezo Igniter	381107	381107	1
12	Cover (optional)	381076	381076	1

(continued on next page)

Gas Fryer (LPG Unit)

INSTALLATION OPERATING & MAINTENANCE INSTRUCTIONS

Fryer's baffle plate install instruction



Figure 1

(End)

Gas Fryer (LPG Unit)

WARRANTY INFORMATION

Limited Warranty for Eagle Products

Metal Masters Foodservice Equipment Co Inc. d/b/a Eagle Group or Eagle Foodservice Equipment (“Eagle”) hereby warrants to you, the original purchaser and end-user (“you” or “your”), that the products manufactured by Eagle that you purchased which accompany this Limited Warranty (“products”) shall be free from defects in materials and workmanship under normal use consistent with the accompanying documentation for a period of one year from the date of the original installation of the equipment, not to exceed 18 months from date of shipment from Eagle. Some exclusions apply, outlined below are the product offerings that have their own individual warranty standards.

Warranty provided is limited to repair, replacement, or refund of the purchase price of the affected goods. Seller shall not be liable for any indirect, special, incidental, punitive, or consequential damages of any kind including loss of use, loss of revenue, or interruption of business.

Failure to have service work approved before work is performed shall not be covered under this warranty. Use of an unauthorized agency will void the warranty.

The warranty covers substantiated travel expenses for up to 2 hours or 100 miles round trip up to a maximum of \$150.00. Any additional costs due to installations that require extra work, time, or travel to gain access to service are the sole responsibility of the equipment purchaser. Any exceptions to these travel and access limitations must be pre-approved by the factory Service Manager.

Accessory items such as faucets, electronic eye faucets, drains, pre-rinse units are covered by a limited warranty of 90 days, unless individual manufacturer warranty allows for additional time.

Eagle also provides individual limited warranties concerning specific product categories.

Eagle Cooking Equipment—including but not limited to all Gas and Electric Griddles, Charbroilers, Hot Plates and Fryers

Eagle will warrant for 12 months from the date of shipment from the factory or 6 months from the date first placed into service (whichever comes first). Units intended for other than household use. These commercial appliances must be installed within surroundings and ventilation requirements as dictated by National and/or local code.

This warranty does not cover any cost associated with maintenance, misuse, abuse, improper installation, pilot light adjustments, pilot outage, improper ventilation, adjustments, alteration, calibration, wrong voltage, wrong gas, voltage or gas conversions, resetting of circuit breakers, or safety controls, overtime charges, mileage in excess of 100 miles, operation contrary to the installation and operating instructions, damage caused by flood, fire or acts of God. The warranty shall not apply if the nameplate has been removed or altered.



- 100 Industrial Boulevard, Clayton, Delaware 19938-8903 U.S.A.
- Phone: 302/653-3000 • 800/441-8440 • Fax: 302/653-2065
- www.eaglegrp.com • www.eaglegrpnews.com • www.eaglemh.com