

Height Adjustable Tables

ASSEMBLY INSTRUCTIONS

CAUTION

INSPECT CONTENTS IMMEDIATELY AND FILE CLAIM WITH DELIVERING CARRIER FOR ANY DAMAGE.
SAVE YOUR BOX AND ALL PACKING MATERIALS.
YOU ARE RESPONSIBLE FOR DAMAGE TO YOUR UNIT IF RETURNED IMPROPERLY PACKED.

Assembly

Your Eagle Group Height Adjustable table has come completely preassembled. No tools are required. It will not need any maintenance or oil over its life time. The lift cylinders are self-contained and preassembled with the required volume of oil.

Warranty

- 1) Any modification will void your warranty.
- 2) Attempting to remove the top will void your warranty.
- 3) Exceeding the load capacity will void your warranty.
- 4) Use of soap, detergents or cleansers on lower extending leg will void your warranty.

Maintenance

- 1) All internal components are self contained requiring no maintenance.
- 2) The lower extending leg should be kept clean. Use only alcohol to wipe the leg. Use of soaps or detergents could cause harm to fittings and bushings.

Operation

To raise the height adjustable table:

- 1) Gently raise handle into locked position (see *figure 1*).
- 2) Rotate handle clockwise.
- 3) Gently pull handle from locked position and lower until relaxed. (see *figure 2*).

To lower the height adjustable table:

- 1) Gently raise handle into locked position (see *figure 1*).
- 2) Rotate handle counterclockwise.
- 3) Gently pull handle from locked position and lower until relaxed (see *figure 2*).

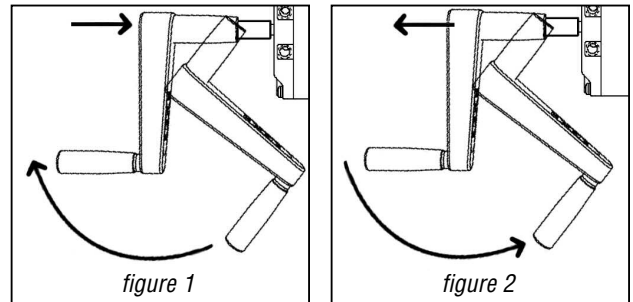

NOTE: If the table surface becomes un-level or stuck, rotate crank counterclockwise to lower table to its lowest possible setting. Apply pressure, if needed, to any stuck legs (do not exceed weight capacity) until the table is level in its lowest setting. Once complete, the table is operational again.

OPERATIONAL WARNINGS AND USE:

- 1) Do not exceed listed weight capacity (see chart below). Be aware of dynamic loading- sudden loading of the table can create moment loads exceeding the table's capacity. Avoid overloading the tables edges. Loads should be placed toward the center of the table and evenly distributed.
- 2) Only operate table on hard flat surfaces.
- 3) All casters (if included) must be in the locked position to operate table.

**Safe operation load capacity (evenly distributed load)
not to exceed the following specifications**

Tables up to 48" long: 575 lbs.

Tables 49" to 72" long: 525 lbs.

EG9933 Revised 05/17



• 100 Industrial Boulevard, Clayton, Delaware 19938-8903 U.S.A. • www.eaglegrp.com
• Phone: 302/653-3000 • (Foodservice) 800/441-8440 • (MHC/Retail) 800/637-5100
• Fax: 302/653-2065