

# Poly/Richlite® Drop Shelf

## ASSEMBLY INSTRUCTIONS

### CAUTION

INSPECT CONTENTS IMMEDIATELY AND FILE CLAIM WITH DELIVERING CARRIER FOR ANY DAMAGE. **SAVE YOUR BOX AND ALL PACKING MATERIALS.** YOU ARE RESPONSIBLE FOR DAMAGE TO YOUR UNIT IF RETURNED IMPROPERLY PACKED.

**Please note:** Locations of drop brackets to be determined by installer. Hardware for attaching drop brackets to wall not included.

### Step 1 - Mark drop bracket holes onto wall.

- Determine location of drop brackets\*.
- Draw centerlines\*\*.
- Using one of the drop brackets as a guide\*\*, mark hole locations onto wall.

\*\* Using a level is strongly suggested to make sure the centerlines are vertically and horizontally level and parallel.

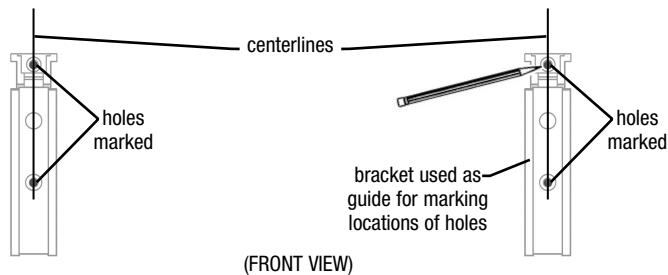

### Step 2 - Pre-drill holes into wall.

Pre-drill pilot holes into wall where holes are marked.



### Step 3 - Attach drop brackets to wall.

Attach to wall using countersink screws (not included).

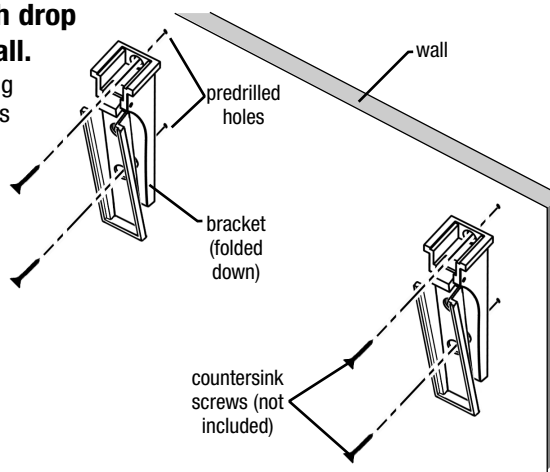

\* **IMPORTANT:** Wall mounted units must be attached to a properly constructed and sound wall. For walls constructed of wood or steel studs, the mounting points must be directly on the stud or suitable in-wall-grounds of plywood or sheet metal. Eagle Group cannot be held responsible for the failure of the device or any other devices due to improper installation.

(continued on page 2)

EG9865 Revised 12/23

# Poly/Richlite® Drop Shelf

## ASSEMBLY INSTRUCTIONS

### Step 4: Mark holes onto underside of shelf.

- Slide one top channel onto one drop bracket flange. Repeat with remaining top channel and bracket.

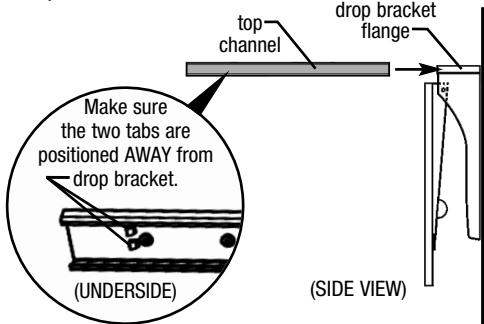

- Carefully center shelf onto top channels (squared edge toward wall), pushing shelf toward wall.
- Locate and mark the 2 accessible holes\* (total 3 holes\* per top channel) onto shelf, then set aside shelf and top channels.

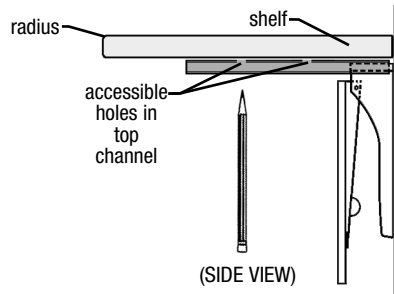

\* PLEASE NOTE: The remaining holes will be accessible in Step 5.

### Step 5 - Predrill holes into shelf.

Using 1/8" bit, predrill pilot holes 5/8" deep maximum into underside of shelf.

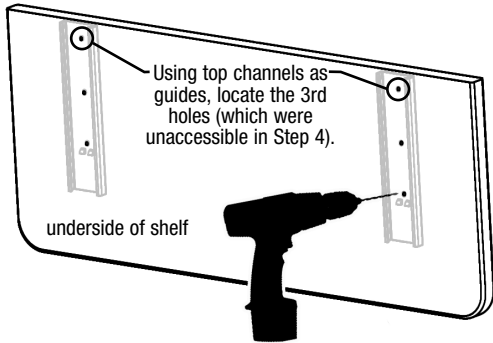

### Step 6 - Attach top channels to shelf.

With screws provided, attach top channels to underside of shelf.

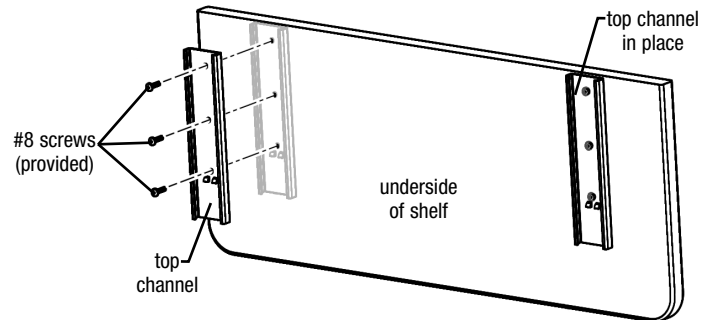

### Step 7 - Attach shelf to drop brackets.

- With drop brackets still folded down, slide top channels (mounted to underside of shelf) onto drop brackets.
- Guide shelf downward until shelf stops.

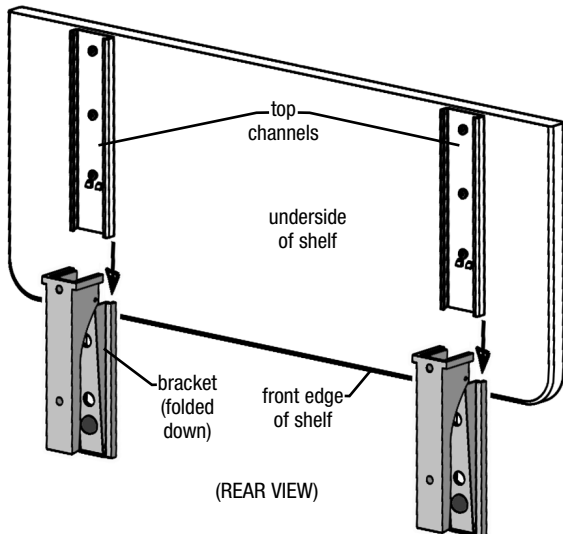

### Step 8 - Position shelf for use.

- Lift front of shelf until drop brackets are at a 90° angle.
- Push shelf back toward wall. Shelf will lock into place.

To drop down shelf: Pull shelf away from wall, and carefully lower front of shelf.

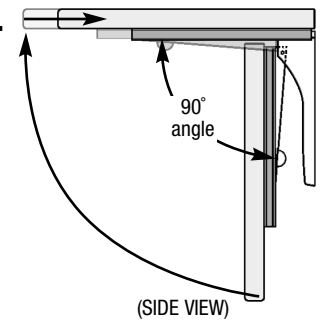

### Additional notes:

- Weight capacity: 80 lbs. evenly distributed.
- Poly shelves can withstand hot items up to 180°F without discoloration.
- Richlite® shelves can withstand hot items up to 350°F without discoloration.

(End)