

Pizza Holding Table

ASSEMBLY INSTRUCTIONS

CAUTION

INSPECT CONTENTS IMMEDIATELY AND FILE CLAIM WITH DELIVERING CARRIER FOR ANY DAMAGE.
SAVE YOUR BOX AND ALL PACKING MATERIALS.
YOU ARE RESPONSIBLE FOR DAMAGE TO YOUR UNIT IF RETURNED IMPROPERLY PACKED.

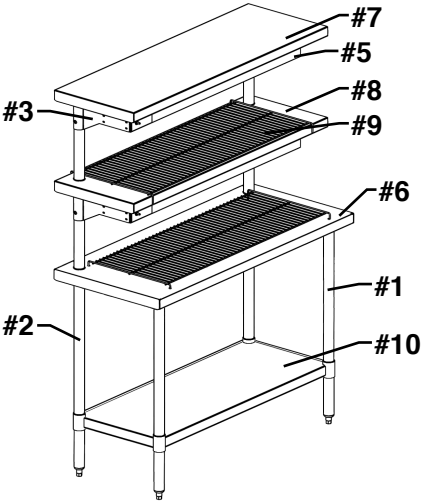

Parts List

#	qty	part #	description
#1	2	300317	33" front legs
#2	2	354161	63" rear legs
#3	2	310058	left brackets
#4	2	310053	right brackets
#5	2	*	food warmers
#6	1	310005	tabletop
#7	1	310007	top overshelf
#8	1	310008	bottom overshelf
#9	2	310046	pizza racks
#10	1	352181	adjustable undershelf
#11	8	310173	bolt, 3/8-16, 2-1/8"
#12	8	310176	nut, 3/8-16

* Varies per order.

Step 1 - While on its side, mount undershelf to legs at desired height. Seat one leg at a time.

- Secure legs to undershelf with set screw* (using 5/32" allen wrench provided).
- Each corner must be at the same height from bottom of legs, or shelf collars could fail.
- Make sure holes in rear legs are facing each other.

NOTE: Undershelf must be level. Use care not to overtighten undershelf set screws* or failure will occur. Recommended height from the floor to the top of undershelf is 10".

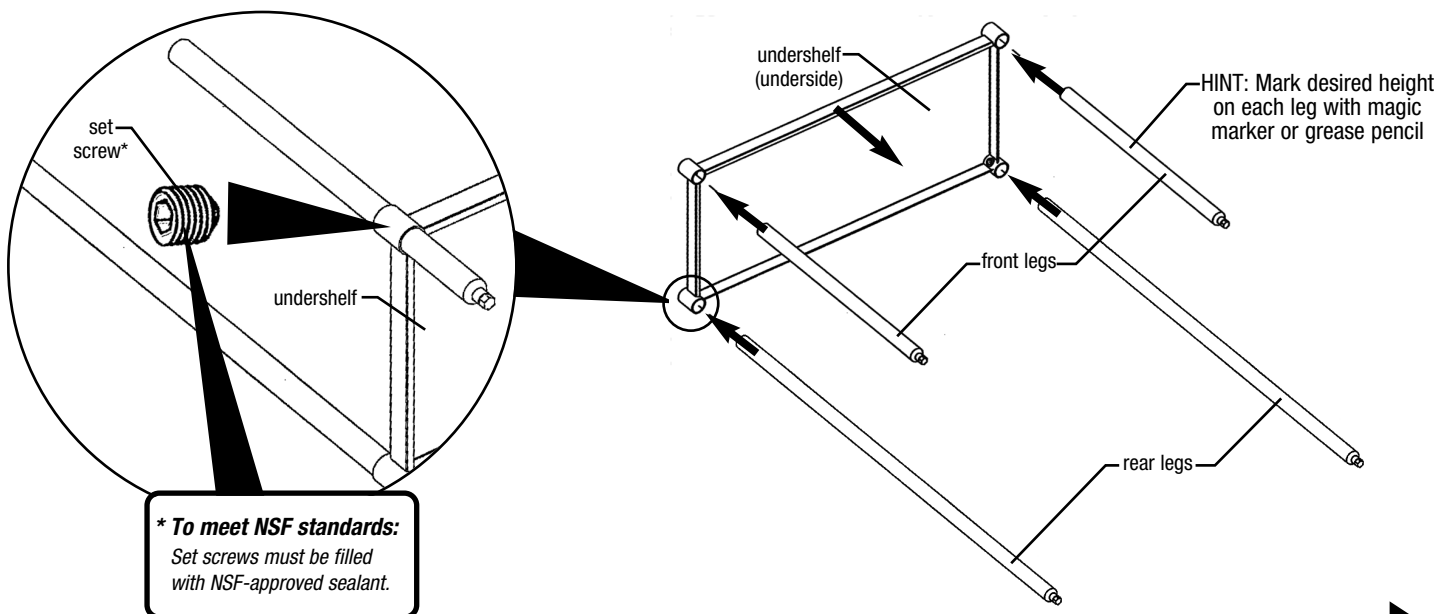

*** To meet NSF standards:**
Set screws must be filled with NSF-approved sealant.

(continued on back page)

EG9860 Revised 02/23

Pizza Holding Table

ASSEMBLY INSTRUCTIONS

Step 2 - Stand table upright and mount tabletop.

- Place tabletop onto top of legs.
- Insert each leg into each tabletop gusset.
- With 5/32" allen wrench, tighten set screw* on each gusset.

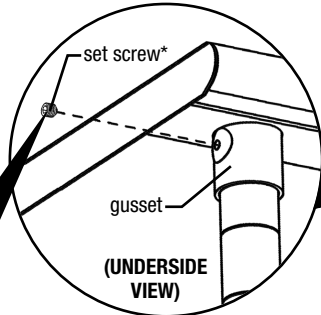

*** To meet NSF standards:**
Set screws must be filled
with NSF-approved sealant.

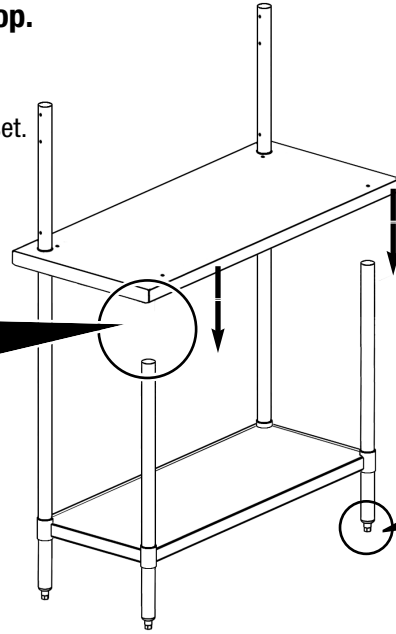

Step 3 - Level unit.

The leveling feet allow
approximately 1" adjustment.

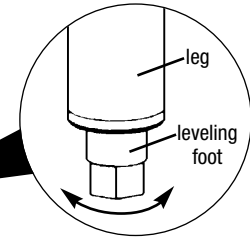

Step 4 - Attach bottom overshelf to rear legs.

- Place overshelf onto top of legs, and slide overshelf down until bracket holes are aligned with bottom set of holes on legs.
- Run bolts (two per bracket) through bracket and legs, and tighten with nuts. Hardware included.

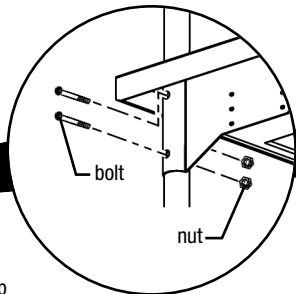
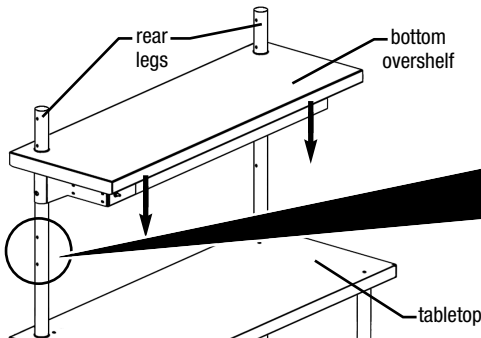

Step 5 - Attach top overshelf to rear legs.

- Place overshelf onto top of legs, aligning bracket holes with holes on legs.
- Run bolts (two per bracket) through bracket and legs, and tighten with nuts. Hardware included.

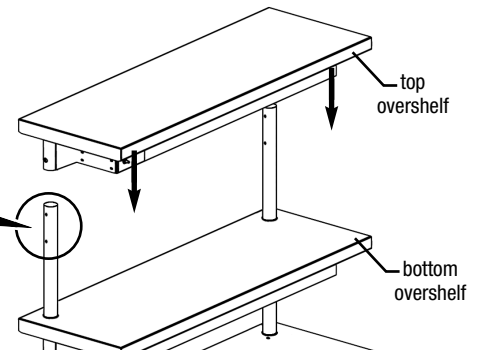

Step 6 - Place racks as shown.

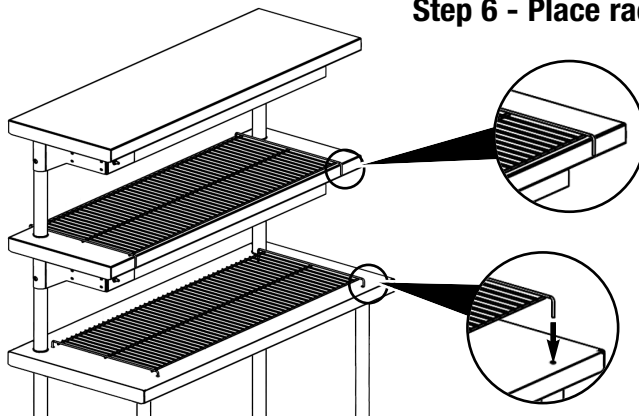

Assembly is complete.

