

Worktables with Drawers

ASSEMBLY INSTRUCTIONS

CAUTION

INSPECT CONTENTS IMMEDIATELY AND FILE CLAIM WITH DELIVERING CARRIER FOR ANY DAMAGE.
SAVE YOUR BOX AND ALL PACKING MATERIALS.
YOU ARE RESPONSIBLE FOR DAMAGE TO YOUR UNIT IF RETURNED IMPROPERLY PACKED.

Step 1

Remove drawer pan from enclosure.

Step 2

Attach drawer angles to drawer enclosure with nuts and bolts.

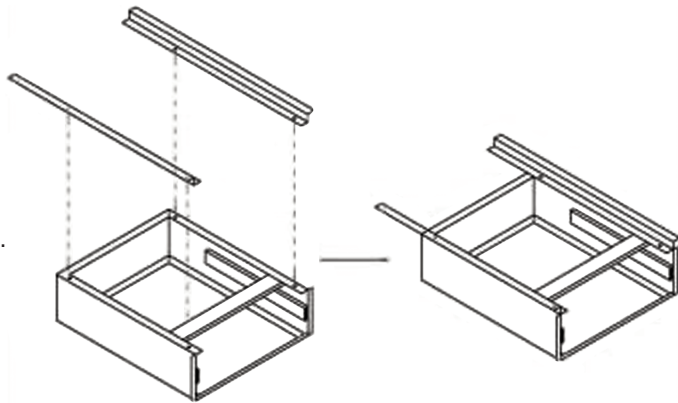

Step 3

Place table top, bottom side up, on cardboard for protection.

Step 4

Decide drawer location, left to right, and place drawer (upside down) on channels.

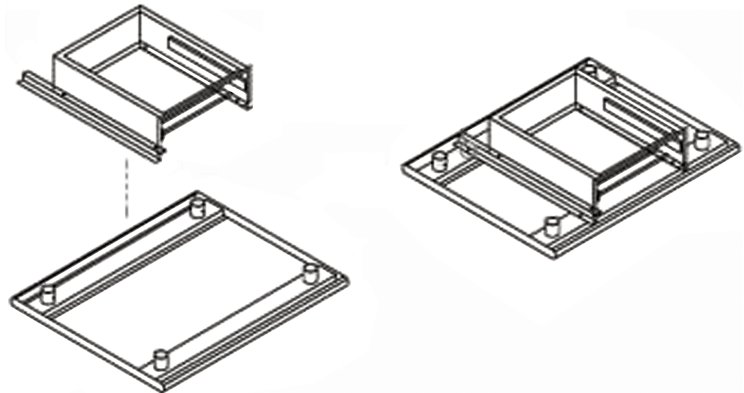

Step 5

Center the drawer angle's holes for mounting on the table channels and attach with (4) self drilling screws.

Caution: Attach carefully so the screws do not go through the top of table.

Step 6

Return table to the upright position (complete with legs and undershelf).

Step 7

Replace drawer pan in enclosure.

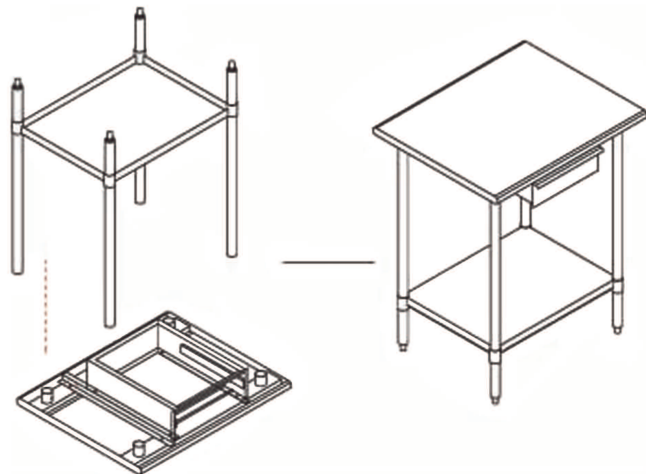

EG9857 Revised 03/11