

Lexan® Canopy

ASSEMBLY INSTRUCTIONS

CAUTION

INSPECT CONTENTS IMMEDIATELY AND FILE CLAIM WITH DELIVERING CARRIER FOR ANY DAMAGE. **SAVE YOUR BOX AND ALL PACKING MATERIALS.** YOU ARE RESPONSIBLE FOR DAMAGE TO YOUR UNIT IF RETURNED IMPROPERLY PACKED.

Thank you for your purchase. Before assembly, read this instruction manual carefully to ensure correct use. After reading, be sure to store this instruction in a safe place, should it be needed for future reference.

Parts List:

#	description	quantity
1	Tubing assembly	2
2	Lexan® canopy	1
3	Oak top board	1
4	Oak side panel	2
5	Oak front panel	2
6	Lexan® close-off	2
7	Bottom cover plate	2
Hardware included:		
8	#320647 10 x 1-1/2 screws	16
9	#313433 10 x 3/4 screws	8
10	#300794 Pan-head Phillips screws	4

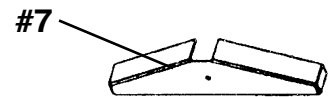
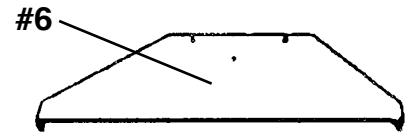
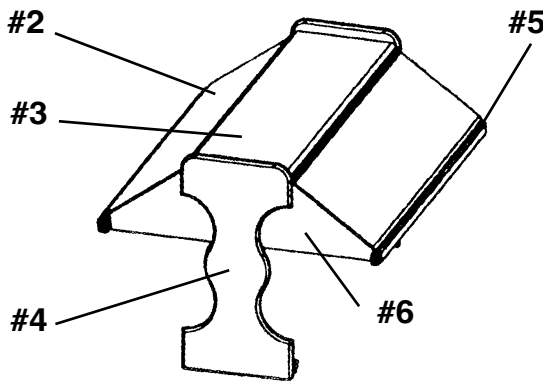
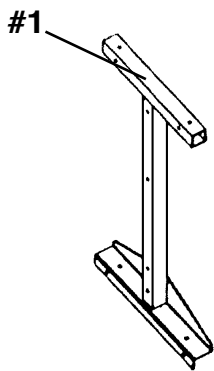

(continued on next page) →

EG9846 Revised 02/24



• 100 Industrial Boulevard, Clayton, Delaware 19938-8903 U.S.A.
• Phone: 302/653-3000 • 800/441-8440 • Fax: 302/653-2065
• www.eaglegrp.com • www.eaglehmc.com

Eagle Foodservice Equipment, Eagle MHC, and SpecFAB® are divisions of Eagle Group. ©2024 by the Eagle Group

Lexan® Canopy

ASSEMBLY INSTRUCTIONS

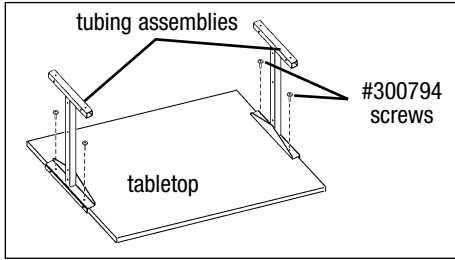

Figure 1

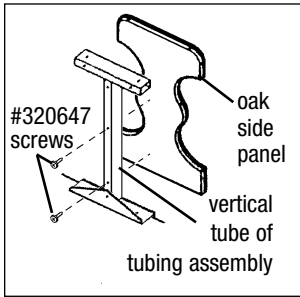

Figure 2

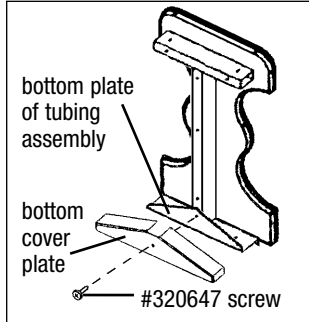

Figure 3

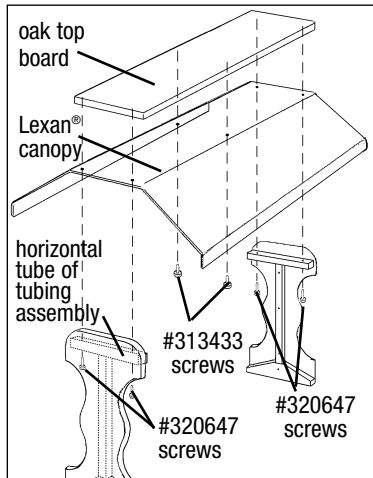

Figure 4

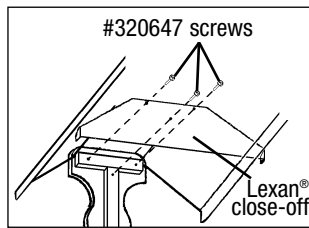

Figure 5

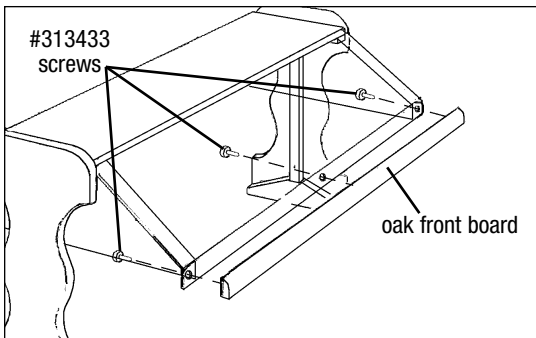

Figure 6

1) Tubing Assemblies

- Remove inner two screws from each end of tabletop.
- Align tabletop holes from which original screws were just removed with tubing assembly holes. Using #300794 screws supplied, secure tubing assemblies to the tabletop as shown in *Figure 1*.

2) Oak Side Panels

- On one end of table, place oak side panel against outer side of tubing assembly. Secure with two #320647 screws through vertical tube of tubing assembly and into oak side panel as shown in *Figure 2*, using the 2nd and 3rd holes from the bottom.
- Align designated hole in bottom cover plate with bottommost hole in tubing assembly. Using one #320647 screw, secure bottom cover plate to bottom plate of tubing assembly – see *Figure 3*. Screw through bottom cover plate and into oak side panel.
- Repeat Steps 2a & 2b to assemble remaining oak side panel to remaining tubing assembly.

3) Assemble Canopy and Oak Top Board

- Place Lexan® canopy onto top of the horizontal tube of both tubing assemblies, aligning all relevant holes.
- Place oak top board onto top of Lexan® canopy until desired location is achieved. Secure both the Lexan® canopy and the oak top board to the tubing assemblies, using two #320647 screws per end through the bottom of the horizontal tube and into the oak top board, and two #313433 screws through the center holes in the Lexan® canopy – see *Figure 4*.
- On one end of table, place Lexan® close-off underneath Lexan® canopy. Align the three holes. Secure Lexan® close-off to the inner side of the tubing assembly and into oak side panel, using three #320647 screws – see *Figure 5*.
- Repeat Step 3c to assemble remaining Lexan® close-off to remaining end of table.

4) Assemble Oak Front Boards

- On one side of table, place oak front board onto outer edge of Lexan® canopy.
- On each end of table, align holes of Lexan® close-off and canopy. Secure both Lexan® pieces to oak front board, using #313433 screws through both Lexan® pieces and into oak front board – see *Figure 6*.
- In center of table, secure Lexan® canopy to oak front board, using #313433 screw through Lexan® canopy and into oak front board – see *Figure 6*.
- Repeat Steps 4a thru 4c to assemble remaining oak front board to remaining side of table.

5) Sealing

Seal all cracks and joints with NSF-approved sealant/caulk.

