

# Ceiling-Mounted Pot Rack

## ASSEMBLY INSTRUCTIONS

### CAUTION

INSPECT CONTENTS IMMEDIATELY AND FILE CLAIM WITH DELIVERING CARRIER FOR ANY DAMAGE.  
**SAVE YOUR BOX AND ALL PACKING MATERIALS.**  
YOU ARE RESPONSIBLE FOR DAMAGE TO YOUR UNIT IF RETURNED IMPROPERLY PACKED.

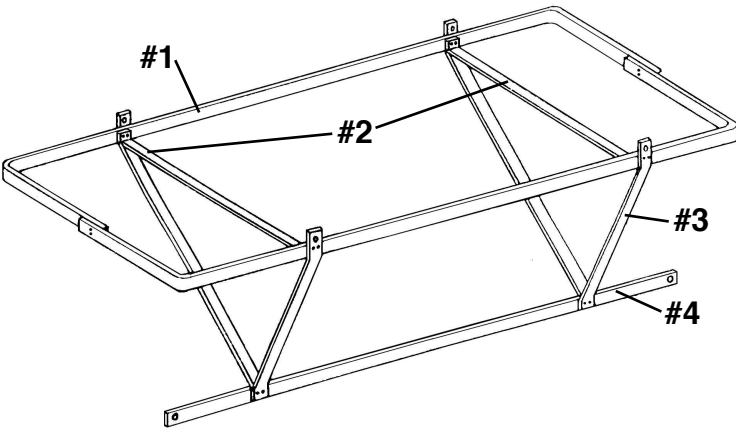

**Parts List**

#	qty	part #	description
#1	2	*	bar - top piece
#2	*	305669	cross top support
#3	*	305668	support
#4	1	*	bottom rack bar
#5	*	306136	hex head bolt 3/8-1"
#6	*	306122	lock washer, 3/8"
#7	*	306137	cap nut, 3/8"
#8	4	306138	hex cap bolt, 3/8"-3/4"

(not shown)

#9	*	300696	double pot hooks
#10	*	354886	S-hooks
#11	*	301260	chain

\* Quantities and/or part numbers vary, depending on size.

actual size of hardware:

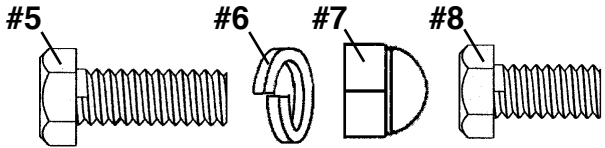

### Step 1 - Assemble top bar.

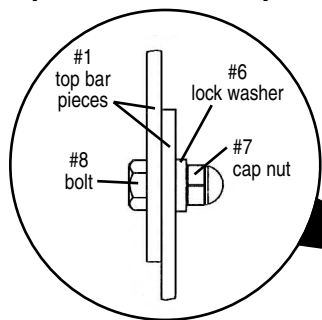

### Step 2 - Attach cross top supports and bottom supports to top bar assembly.

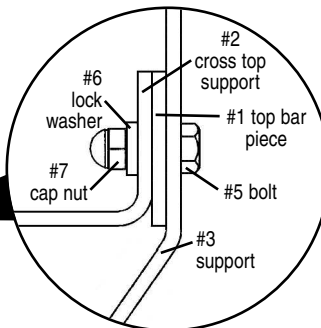

### Step 3 - Attach bottom rack bar.

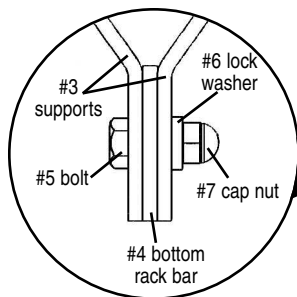

### Step 4 - Install S-hooks and chain, then hang from ceiling.

Please note: Maximum workload capacity is 600 lbs.

EG9843 Revised 08/16



• 100 Industrial Boulevard, Clayton, Delaware 19938-8903 U.S.A. • [www.eaglegrp.com](http://www.eaglegrp.com)  
• Phone: 302/653-3000 • (Foodservice) 800/441-8440 • (MHC/Retail) 800/637-5100  
• Fax: 302/653-2065