

Utility Cart

ASSEMBLY INSTRUCTIONS

CAUTION

INSPECT CONTENTS IMMEDIATELY AND FILE CLAIM WITH DELIVERING CARRIER FOR ANY DAMAGE. **SAVE YOUR BOX AND ALL PACKING MATERIALS.** YOU ARE RESPONSIBLE FOR DAMAGE TO YOUR UNIT IF RETURNED IMPROPERLY PACKED.

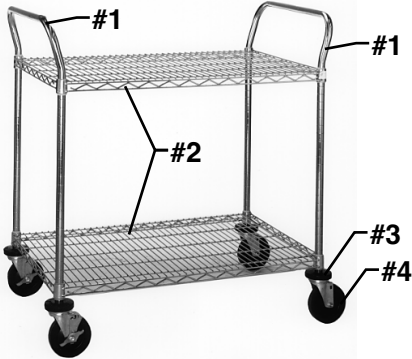

Parts List

#	qty	description
#1	2	"U" handle assembly
#2	*	wire shelves
#3	4	donut bumpers
#4	4	stem casters
#5	*	split sleeves (pack of four)
#6	4	double-threaded bolt **

* Quantity will vary per order.
** For carts with zinc or chrome finish only.

PLEASE READ BEFORE ASSEMBLY...

If your cart is plated in zinc or chrome, you must assemble the "U"-handles PRIOR TO cart assembly. Assemble as shown.

If your cart is stainless steel, skip this and proceed to **Step 1**.

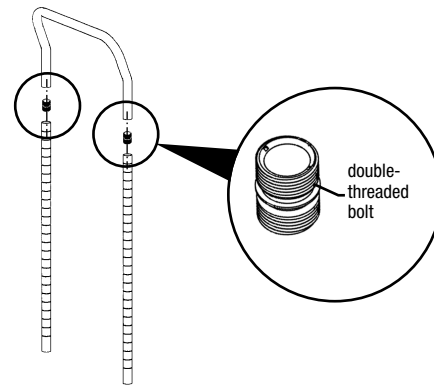

Step 1 - Mount top shelf.

- Slide shelf toward top of "U" handle legs.
- Attach split sleeves to top groove of "U" handle legs (see *figure 1a*). The wider part of the taper goes toward the bottom.
- Slide shelf down onto split sleeves (see *figure 1b*).

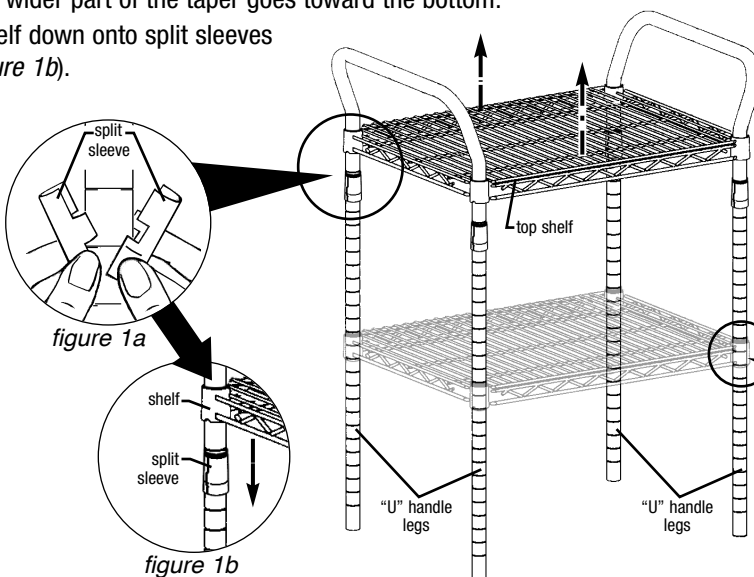

Before continuing, please note:

Step 2 pertains to carts with three shelves. If your cart has only two shelves, skip **Step 2** and proceed to **Step 3**.

Step 2 - Mount mid shelf.

- Slide shelf toward top of "U" handle legs.
- Attach split sleeves (see *figure 1a*) to "U" handle legs at desired height.
- Slide shelf down onto split sleeves (see *figure 2*).

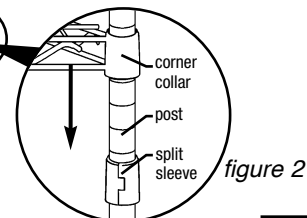

(continued on back page)

EG9830 Revised 04/24

Utility Cart

ASSEMBLY INSTRUCTIONS

Step 3 - Mount bottom shelf.

- Slide shelf toward top of “U” handle legs.
- Attach split sleeves to bottom groove of “U” handle legs (see *figure 3a*).
- Slide shelf down onto split sleeves (see *figure 3b*).

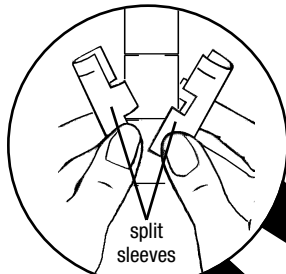

figure 3a

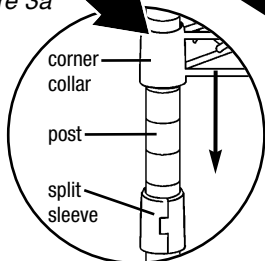
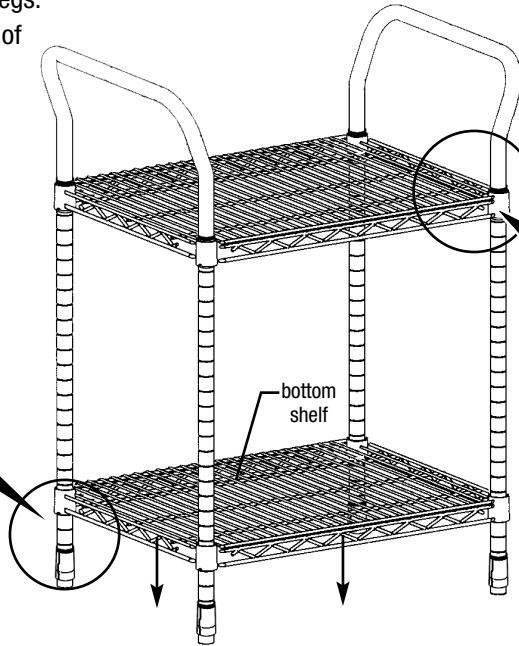

figure 3b



Step 4: Securely seat all shelves.

- On each shelf, lay a board diagonally across the front and side wire shelf trusses, and firmly seat shelf onto split sleeves with a rubber mallet (see *figure 4*).
- Do NOT hammer directly on shelf.
- Repeat on remaining corners.

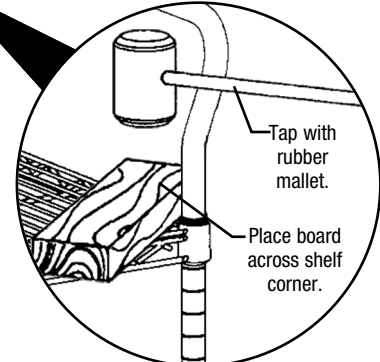
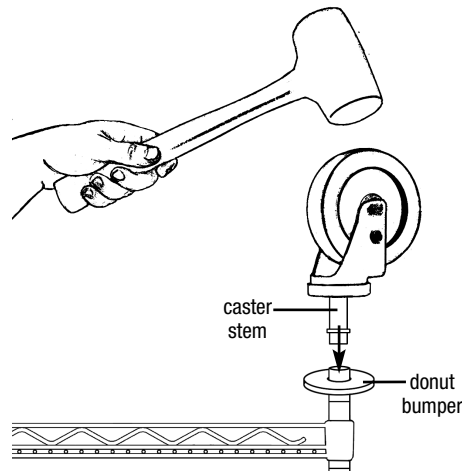

figure 4

Step 5 - Secure casters to unit.

- Place donut bumpers onto ends of “U” handle legs.
- Place caster stems into bottom of “U” handle legs and drive caster, using a hammer or mallet (several solid blows are usually required).



Assembly is complete.

(End)