

Bulk Wine Shelving

ASSEMBLY INSTRUCTIONS

CAUTION

INSPECT CONTENTS IMMEDIATELY AND FILE CLAIM WITH DELIVERING CARRIER FOR ANY DAMAGE. **SAVE YOUR BOX AND ALL PACKING MATERIALS.** YOU ARE RESPONSIBLE FOR DAMAGE TO YOUR UNIT IF RETURNED IMPROPERLY PACKED.

Parts List

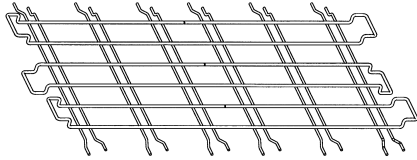

rear enclosure panel
quantity: 3

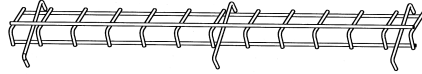

bottle support
quantity: 3

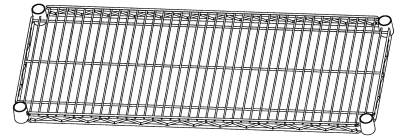

wire shelf
quantity: 4*
* quantity of 2 for SC-style units

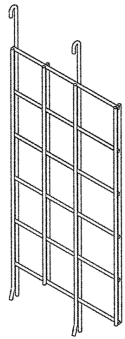

8"-wide bin divider
quantity: varies per order

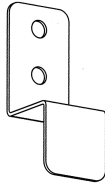

wall clamp
quantity: 6

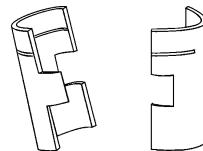

split sleeve - 4 sets

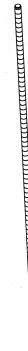

74"-high post
quantity: 4

for SC style units only:

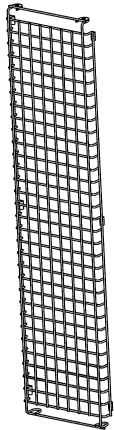

end panel
quantity: 2

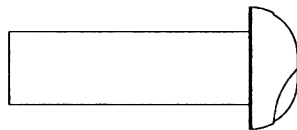

#311981 one-way bolt
(actual size)



left-hand door
quantity: 1

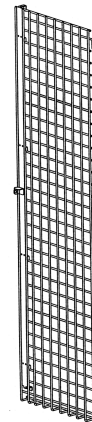

right-hand door
quantity: 1

(continued on Page 2)

EG9824 Revised 02/24

Bulk Wine Shelving

ASSEMBLY INSTRUCTIONS

Step 1 - Attach split sleeves (for bottom shelf) to #10 groove on posts.

- The wider part of the taper goes toward the bottom.
- Make sure rib on split sleeve is seated into a groove on the post.

Note: The number covered by the split sleeve indicates approximate height of shelf.

IMPORTANT: "SC"-style units include two wire shelves with a notch along the mid front. Make sure to install notched shelf as bottom and top shelf of unit.

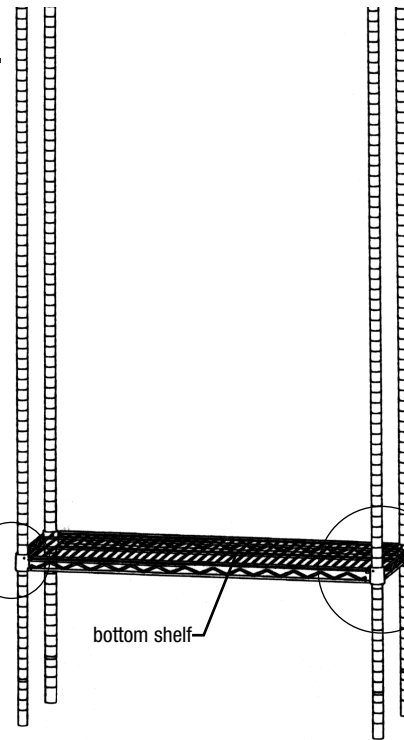
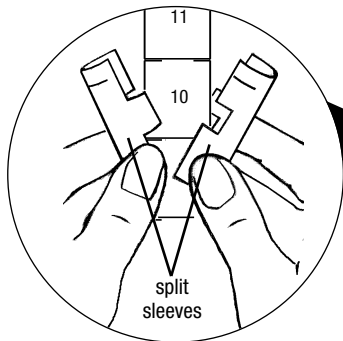

Step 2 - Mount bottom shelf.

Slide bottom shelf collars over posts and down onto split sleeves.

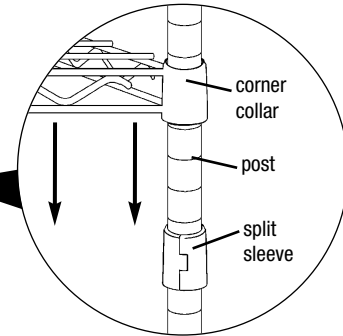

Step 3 - Slip rear enclosure panel over rear posts and seat onto wire shelf.

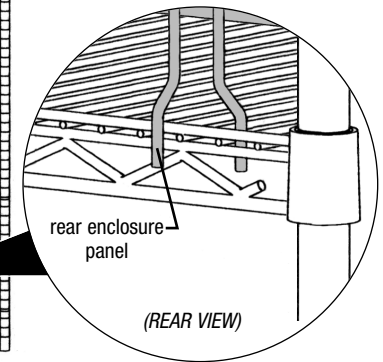
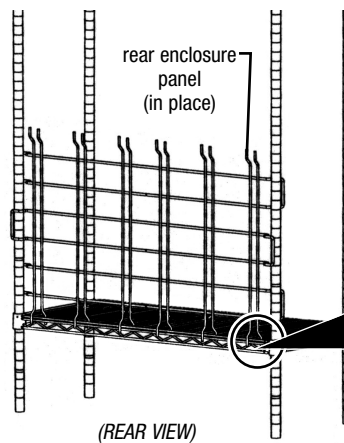
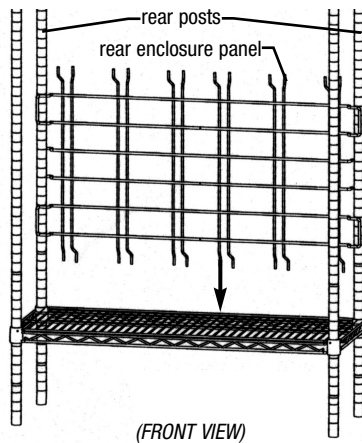

Step 4 - Install next shelf to unit.

- Repeat Step 1, snapping split sleeves onto #31 groove on posts.
- Lower shelf onto split sleeves.

Run wires of rear enclosure panel through rear wire shelf truss.

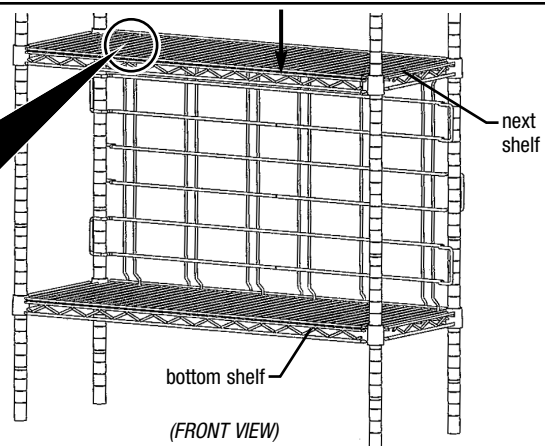
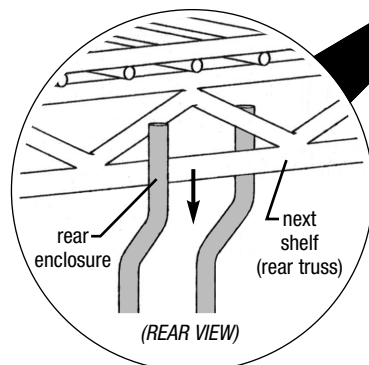

(continued on Page 3)

Bulk Wine Shelving

ASSEMBLY INSTRUCTIONS

Step 5 - Seat bottle support onto wire shelf towards front.

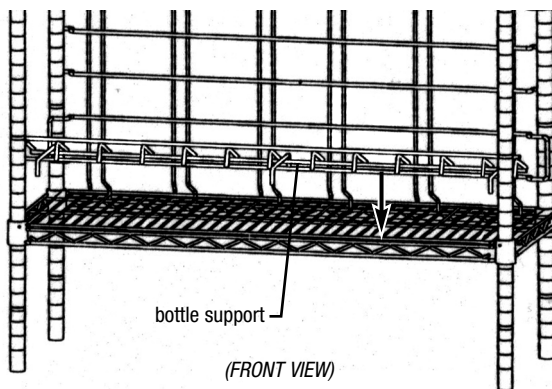

Step 6 - Attach bin dividers.

Hook bin dividers onto desired locations of next shelf.

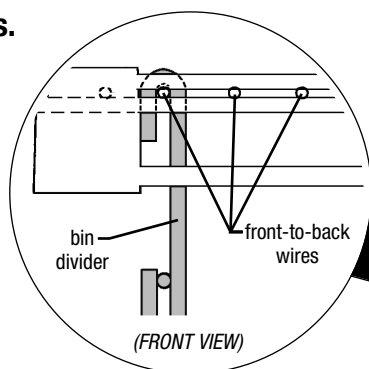

Run bottom wires of bin dividers through front-to-back wires of bottom shelf.

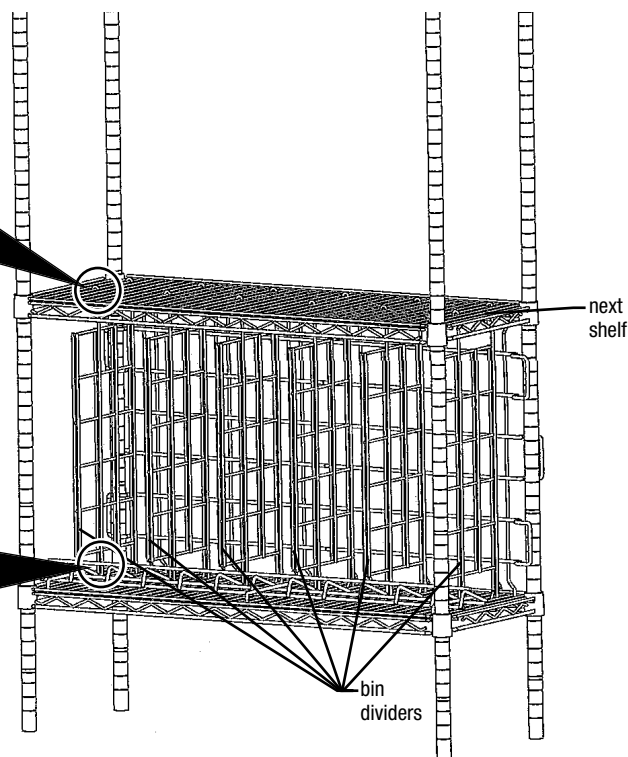
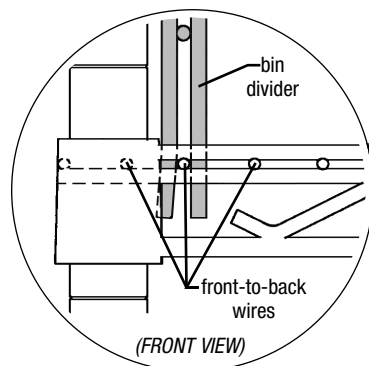

PLEASE READ BEFORE CONTINUING:

Repeat Steps 3 through 6 to install remaining tiers, snapping split sleeves onto #52 groove on posts (for third shelf) and onto #73 groove on posts (for top shelf).

(continued on back page) 

Bulk Wine Shelving

ASSEMBLY INSTRUCTIONS

Step 7 - Fasten rear truss of top shelf to wall, using wall clips.

Note: Screws not included.

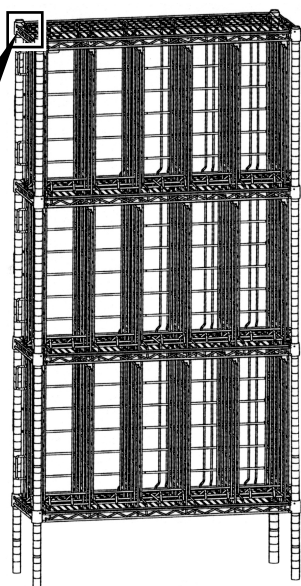
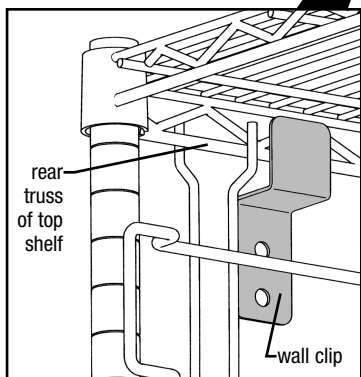

Step 8 - Install end panels (for SC-style units only).

- Tilt unit onto one side to install end panel.
- Install one-way security bolts.

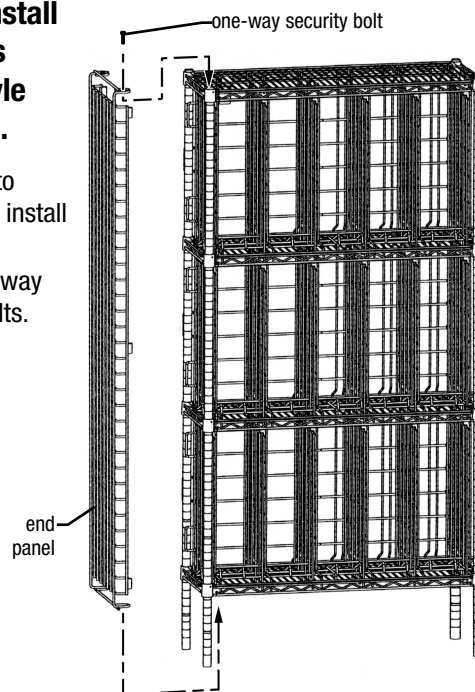

Step 9 - Install doors (for SC-style units only).

Drop doors into hinge tubes of end panels.

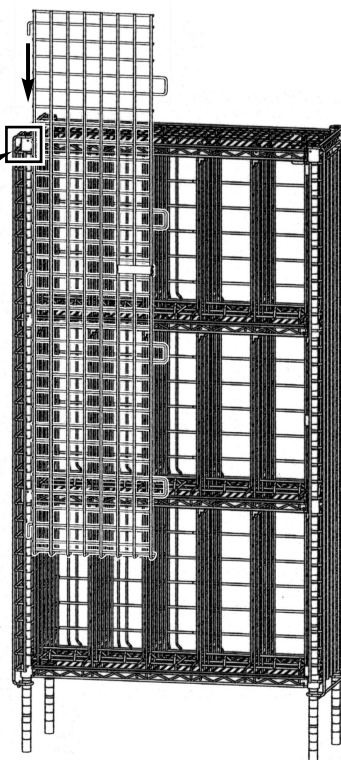
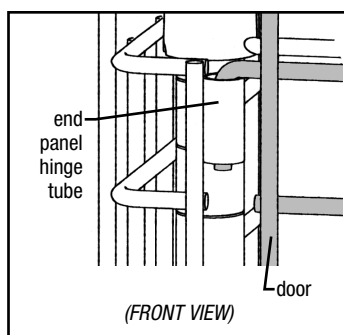

(End)