

Mobile Computer Workstation

ASSEMBLY INSTRUCTIONS

CAUTION

INSPECT CONTENTS IMMEDIATELY AND FILE CLAIM WITH DELIVERING CARRIER FOR ANY DAMAGE.
SAVE YOUR BOX AND ALL PACKING MATERIALS.
YOU ARE RESPONSIBLE FOR DAMAGE TO YOUR UNIT IF RETURNED IMPROPERLY PACKED.



Parts List:

#	Description	Quantity
1	12" x 24" Cantilever Shelf	1
2	48" Posts	2
3	24" x 24" Wire Shelf Tabletop	1
4	Keyboard Drawer	1
5	Mouse Shelf (sold separately)	1
6	33" Posts	2
7	14" x 24" Wire Undershell	1
8	7" Posts	2
9	3-Sided Channel Frame	1
10	Casters with Brake	2
11	Casters without Brake	2

NOT SHOWN:
Sets of Four Split Sleeves 4

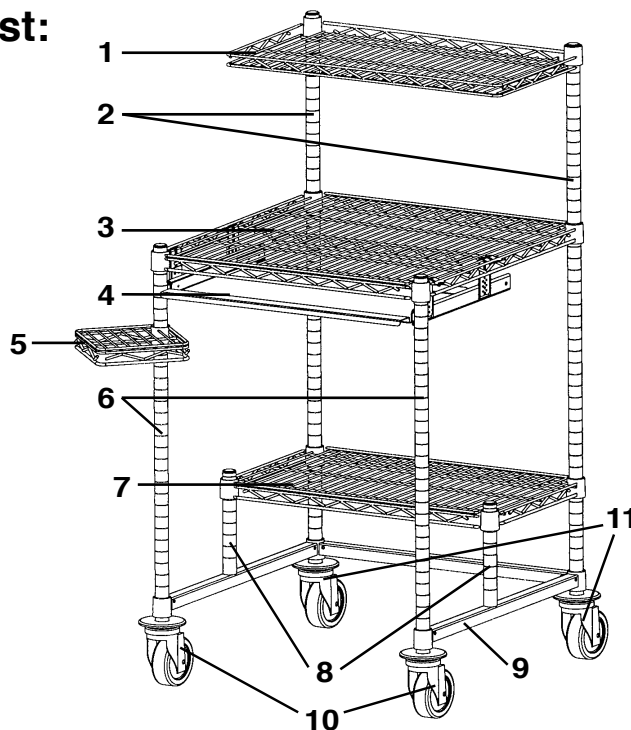

(continued on back page) →

EG9803 Revised 06/21



• 100 Industrial Boulevard, Clayton, Delaware 19938-8903 U.S.A.
• Phone: 302/653-3000 • 800/441-8440
• Fax: 302/653-2065 • www.eaglegrp.com

Eagle Foodservice Equipment, Eagle MHC, and SpecFAB® are divisions of Eagle Group. ©2021 by the Eagle Group

Notes for assembly:

- When assembling plastic split sleeves onto posts, be sure the thicker part of the taper goes toward the bottom. Make sure the rib inside split sleeve is seated into groove on the post.
- When installing 3-sided frame, shelves, and mouse shelf (sold separately), be sure the thicker part of the collars goes toward the bottom.

1 Install 3-sided frame

- Assemble plastic split sleeves onto 2" mark on all posts (see Figure 1a).
- Insert posts through collars of 3-sided frame as shown in Figure 1b. Slide 3-sided frame down onto split sleeves. 33" posts should indicate front of unit.

Note: Bottom of each post is the end with groove $1\frac{7}{16}$ " from the end.

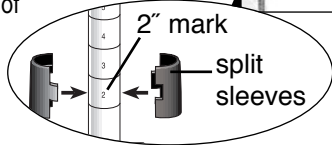

Figure 1b

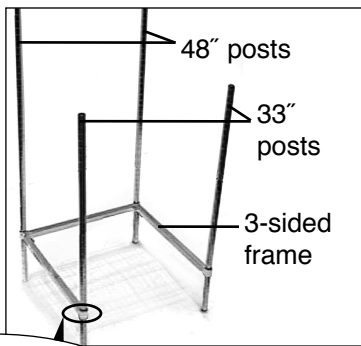

Figure 1a

3 Install mouse shelf (sold separately)

- Assemble split sleeve onto 29" mark on either left or right 33" post (see Figure 3), depending on preference.
- Slide the mouse shelf collar down the post and onto split sleeve. Mouse shelf should be able to swivel on split sleeve and post.

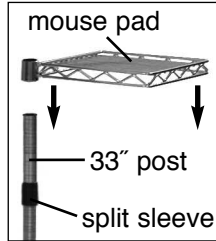

Figure 3

5 Install 12" x 24" cantilever shelf

- Assemble split sleeves onto 48" mark on 48" posts.
- Insert 48" posts through cantilever shelf collars and slide shelf down onto split sleeves (see Figure 5).

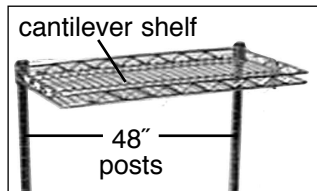

Figure 5

7 Assemble casters to posts

Note: Install casters with brakes onto the 33" posts.

- Gently lay unit on its side or back, giving access to bottom of posts.
- Install donut bumper onto bottom of each post.
- Insert caster stem into bottom of each post. Drive caster in, using a hammer or mallet. Several solid hits are usually required.

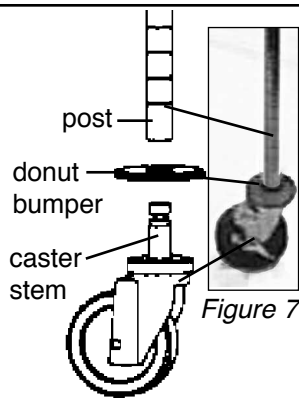

Figure 7

2 Install 14" x 24" wire undershelf

- Assemble plastic split sleeves onto topmost mark on both 7" posts.
- Assemble wire shelf to 7" posts (see Figure 2a).
- Assemble plastic split sleeves onto 9" mark on 48" posts.
- Insert the 48" posts through remaining undershelf collars and slide assembly down onto split sleeves. 7" posts should rest on 3-sided frame (see Figure 2b).

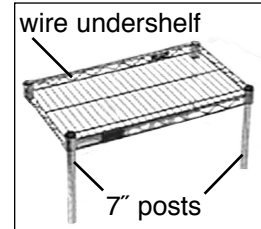

Figure 2a

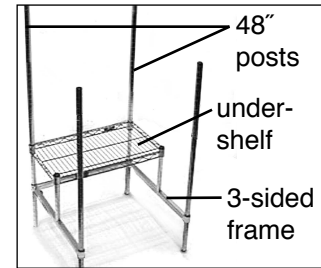

Figure 2b

4 Install 24" x 24" wire shelf tabletop

- Assemble split sleeves onto 32" mark on all posts.
 - Position shelf over 4 vertical posts and slide down until shelf collars seat on plastic split sleeves.
- Note: Shelf trusses should run left-to-right as shown.

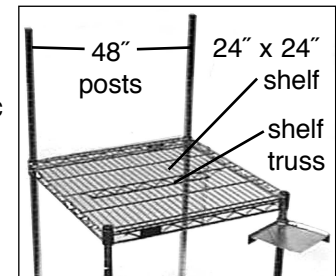

Figure 4

6 Install keyboard drawer

- Position keyboard drawer under tabletop.
- Hook drawer slides over outermost front-to-back trusses of tabletop on each side.

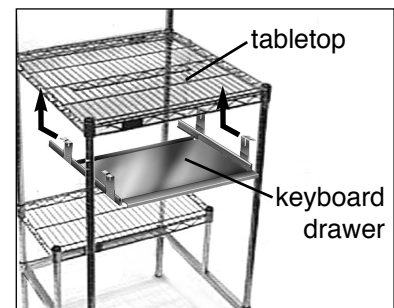

Figure 6

Assembly is complete.

