



Profit from the Eagle Advantage®

# Specification Sheet

## Short Form Specifications

Eagle Panco® “Z” Type Nesting Rack, model \_\_\_\_\_.  
All-welded aluminum construction. “Z” shaped horizontal supports and base allow racks to take up less floor space, and “nest” inside each other. Slide spacing is 2” or 3” to accommodate (20 or 30) 18” x 26” sheet pans. Furnished with 5”-diameter casters. Shipped assembled.

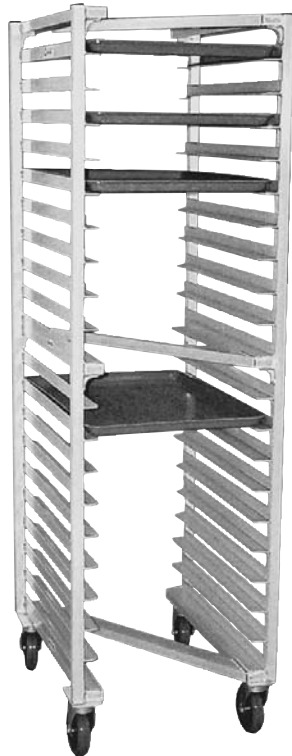

#OUR-1820-3-N  
“Z” type nesting rack

## Options / Accessories

- Casters with locking brakes
- Vertical bumpers

## EAGLE GROUP

100 Industrial Boulevard, Clayton, DE 19938-8903 USA  
Phone: 302-653-3000 • Fax: 302-653-2065  
www.eaglegrp.com

Foodservice Division: Phone 800-441-8440

MHC/Retail Display Divisions: Phone 800-637-5100

For custom configuration or fabrication needs, contact our **SpecFAB®** Division.  
Phone: 302-653-3000 • Fax: 302-653-3091 • e-mail: specfab@eaglegrp.com

Item No.:	_____
Project No.:	_____
S.I.S. No.:	_____

# Panco® “Z” Type Nesting Racks

## MODELS:

- OUR-1820-3-N
- OUR-1830-2-N

## Design and Construction Features

- “Z”-shaped horizontal supports and base allow these racks to take up less square footage than standard racks when not in use; Racks “nest” inside each other.
- These racks accommodate 18” x 26” (457 x 660mm) sheet pans.
- Heavy duty all-welded aluminum construction.
- Units available with pan capacity of 20 or 30.
- 5” (127mm)-diameter heavy duty plate casters.
- All models shipped assembled.



EG60.29 Rev. 08/08

**Spec sheets available for viewing, printing or downloading from our online literature library at [www.eaglegrp.com](http://www.eaglegrp.com)**

Eagle Foodservice Equipment, Eagle MHC, SpecFAB®, and Retail Display are divisions of Eagle Group. ©2008 by the Eagle Group



Item No.: \_\_\_\_\_  
 Project No.: \_\_\_\_\_  
 S.I.S. No.: \_\_\_\_\_

# Panco® "Z" Type Nesting Racks

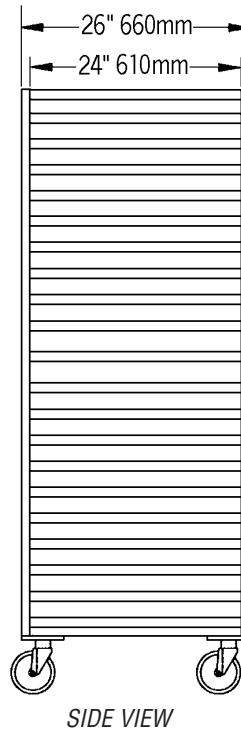
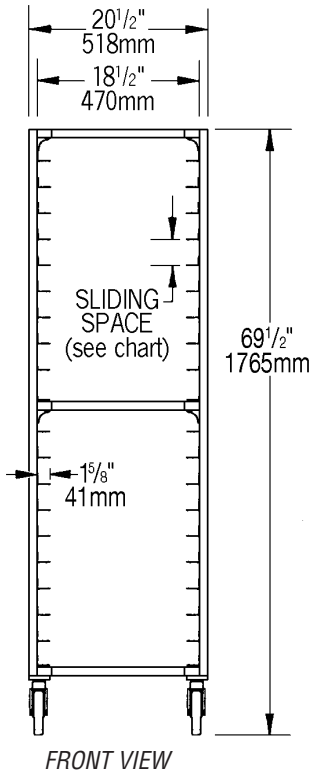
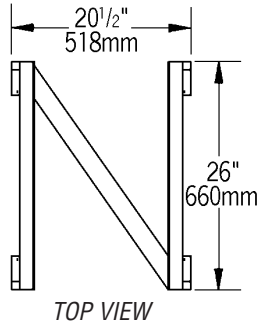

model #	overall dimensions				weight		slide spacing		pan capacity		
	width in.	width mm	depth in.	depth mm	height in.	height mm	lbs.	kg			
OUR-1820-3-N	20 1/2"	521	26"	660	69 1/2"	1765	72	32.7	3"	76	20
OUR-1830-2-N	20 1/2"	521	26"	660	69 1/2"	1765	86	39.0	2"	51	30

**EAGLE GROUP**  
 100 Industrial Boulevard, Clayton, DE 19938-8903 USA  
 Phone: 302-653-3000 • Fax: 302-653-2065  
 www.eaglegrp.com

Foodservice Division: Phone 800-441-8440  
 MHC/Retail Display Divisions: Phone 800-637-5100

Printed in U.S.A.  
 ©2008 by Eagle Group  
 Rev. 08/08

Spec sheets available for viewing, printing or downloading from our online literature library at [www.eaglegrp.com](http://www.eaglegrp.com)

Although every attempt has been made to ensure the accuracy of the information provided, we cannot be held responsible for typographical or printing errors. Information and specifications are subject to change without notice. Please confirm at time of order.