



Profit from the Eagle Advantage®

# Specification Sheet

## Short Form Specifications

Eagle LIFETIME Series Stepped Angle Rack, model \_\_\_\_\_ . Constructed of heavy duty 6063-T5 aluminum alloy. Fully welded frame, 1" square tubular crossbracing, base consists of 1½" x 1½" square aluminum tubing with caster plates welded to bottom, 6⅝" wide "stepped-type" extruded aluminum angle slides welded to uprights. Lifetime guarantee against rust, corrosion, workmanship and material defects.



LIFETIME Series stepped-angle pan rack

## Options / Accessories

- Caster locks
- Perimeter bumpers
- Corner bumpers
- Pan stop
- Solid base

## EAGLE GROUP

100 Industrial Boulevard, Clayton, DE 19938-8903 USA  
 Phone: 302-653-3000 • 800-441-8440 • Fax: 302-653-2065  
[www.eaglegrp.com](http://www.eaglegrp.com)  
[www.eaglegrpnews.com](http://www.eaglegrpnews.com)  
[www.eaglegrp.com](http://www.eaglegrp.com)

For custom configuration or fabrication needs, contact our SpecFAB® Division.  
 Phone: 302-653-3000 • Fax: 302-653-2065 • e-mail: [quotes@eaglegrp.com](mailto:quotes@eaglegrp.com)

Item No.:	_____
Project No.:	_____
S.I.S. No.:	_____

# LIFETIME Series Stepped-Angle Racks

## MODELS:

- 4640
- 4642
- 4635
- 4637

## Design and Construction Features

- LIFETIME GUARANTEE against:
  - rust and corrosion
  - material defects and workmanship
- Racks accommodate a variety of sheet pans and trays.
- Fully-welded frame features 1½" x 1¼" (38 x 45mm) heavy-duty "D"-shaped tube construction.
- All heavy duty type 6463-T5 alloy aluminum welded construction.
- Crossbracing consists of 1" (25mm) square tubing.
- Unit base consists of 1½" (38mm) square aluminum tubing with caster plates welded to the bottom.
- Heavy duty 6" x 2" (152 x 51mm) non-marking swivel plate casters.
- 6⅝" (157mm)-wide "stepped-type" extruded angle slides are welded to uprights.
- Three welds per angle connection.





Profit from the Eagle Advantage®

Item No.: \_\_\_\_\_  
 Project No.: \_\_\_\_\_  
 S.I.S. No.: \_\_\_\_\_

## LIFETIME Series Stepped-Angle Racks

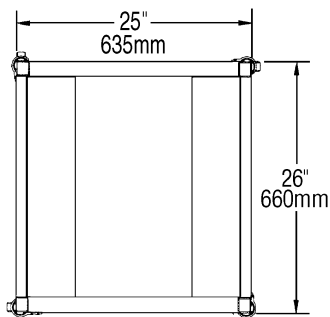

TOP VIEW

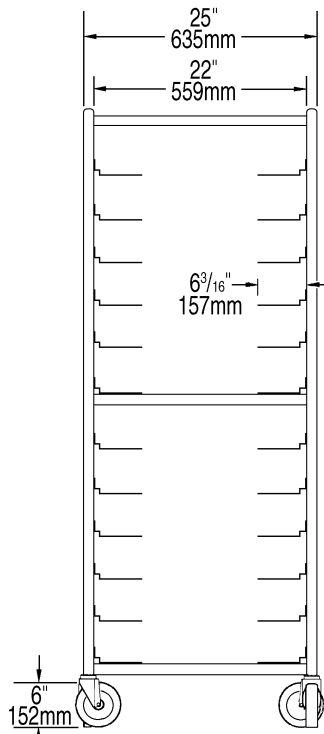

FRONT VIEW

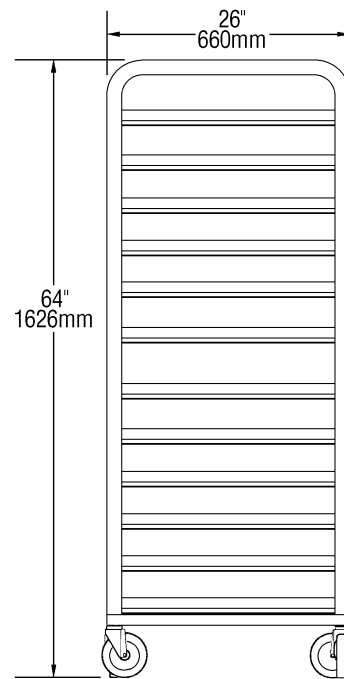

SIDE VIEW

### Sizes of Applicable Pans & Trays:

- Roast/bake pans: 20" x 22", 18" x 26", 10" x 20"
- Steamtable pans: 12" x 18", 12" x 20"
- Bun pans: 18" x 13", 18" x 26"
- Service trays: 15" x 20", 14" x 18"
- Maxi pan: 20¾" x 25½"
- Standard gastro-norm pans: 20¾" x 25½"

(note: stepped-angle roll-in rack shown)

### Roll-In Racks

model #	overall dimensions						weight		slide spacing		number of slides
	width		depth		height		lbs.	kg	in.	mm	
4635	25"	635	26"	660	64"	1626	91	41.3	4½"	114	12
4637	25"	635	26"	660	64"	1626	114	51.7	3"	76	18

### Pan Racks

model #	overall dimensions						weight		slide spacing		number of slides
	width		depth		height		lbs.	kg	in.	mm	
4640	25"	635	26"	660	73"	1854	92	41.7	4½"	114	12
4642	25"	635	26"	660	73"	1854	74	33.6	3"	76	18

### EAGLE GROUP

100 Industrial Boulevard, Clayton, DE 19938-8903 USA

Phone: 302-653-3000 or 800-441-8440 • Fax: 302-653-2065

www.eaglegrp.com • www.eaglegrpnews.com • www.eaglehmc.com

Printed in U.S.A.  
 ©2023 by Eagle Group

Rev. 08/23

Spec sheets available for viewing, printing or downloading from our online literature library at our websites

Although every attempt has been made to ensure the accuracy of the information provided, we cannot be held responsible for typographical or printing errors. Information and specifications are subject to change without notice. Please confirm at time of order.