



Profit from the Eagle Advantage®

# Specification Sheet

## Short Form Specifications

Eagle Panco® Open Lug Rack, model \_\_\_\_\_.  
All-welded aluminum construction with 1" square tubular frame and supports. Crossbracing runs side-to-side and front-to-back on top and bottom. 1 1/16" x 1 3/8" extruded aluminum angle tray slides. Slide spacing is 10 1/16" to accommodate (6, 4, 2, or 1) lugs. Furnished with 5"-diameter casters. Shipped assembled.



model #OLR-6A

## Options / Accessories

- Casters with locking brakes
- Rotary bumpers
- Perimeter bumper
- Vertical corner bumpers
- Pan stop
- Nesting lug bin (#NL1626)

## EAGLE GROUP

100 Industrial Boulevard, Clayton, DE 19938-8903 USA  
Phone: 302-653-3000 • Fax: 302-653-2065  
www.eaglegrp.com

Foodservice Division: Phone 800-441-8440

MHC/Retail Display Divisions: Phone 800-637-5100

For custom configuration or fabrication needs, contact our **SpecFAB®** Division.  
Phone: 302-653-3000 • Fax: 302-653-2065 • e-mail: quotes@eaglegrp.com

Item No.:	_____
Project No.:	_____
S.I.S. No.:	_____

## Panco® Open Lug Racks

### MODELS:

- OLR-6A
- OLR-4A
- OLR-2A
- OLR-1A
- NL1626

### Design and Construction Features

- Heavy duty all-aluminum welded construction.
- Frame and supports: 1" (25mm) square aluminum tubing. Crossbracing runs side-to-side and front-to-back on top and bottom of unit.
- Tray slides: extruded aluminum angle 1 1/16" high x 1 3/8" wide x 1/16"-thick (37 x 48 x 2mm) bearing surface. Slides are riveted to frame 10 1/16" (272mm) apart.
- Casters: 5" (127mm)-diameter non-marking swivel stem plated casters with polymer tread.
- Shipped assembled.



## AUTOQUOTES



EG60.19 Rev. 06/14

**Spec sheets available for viewing, printing or downloading from our online literature library at [www.eaglegrp.com](http://www.eaglegrp.com)**

Eagle Foodservice Equipment, Eagle MHC, SpecFAB®, and Retail Display are divisions of Eagle Group. ©2014 by the Eagle Group



Item No.: \_\_\_\_\_  
 Project No.: \_\_\_\_\_  
 S.I.S. No.: \_\_\_\_\_

# Panco® Open Lug Racks

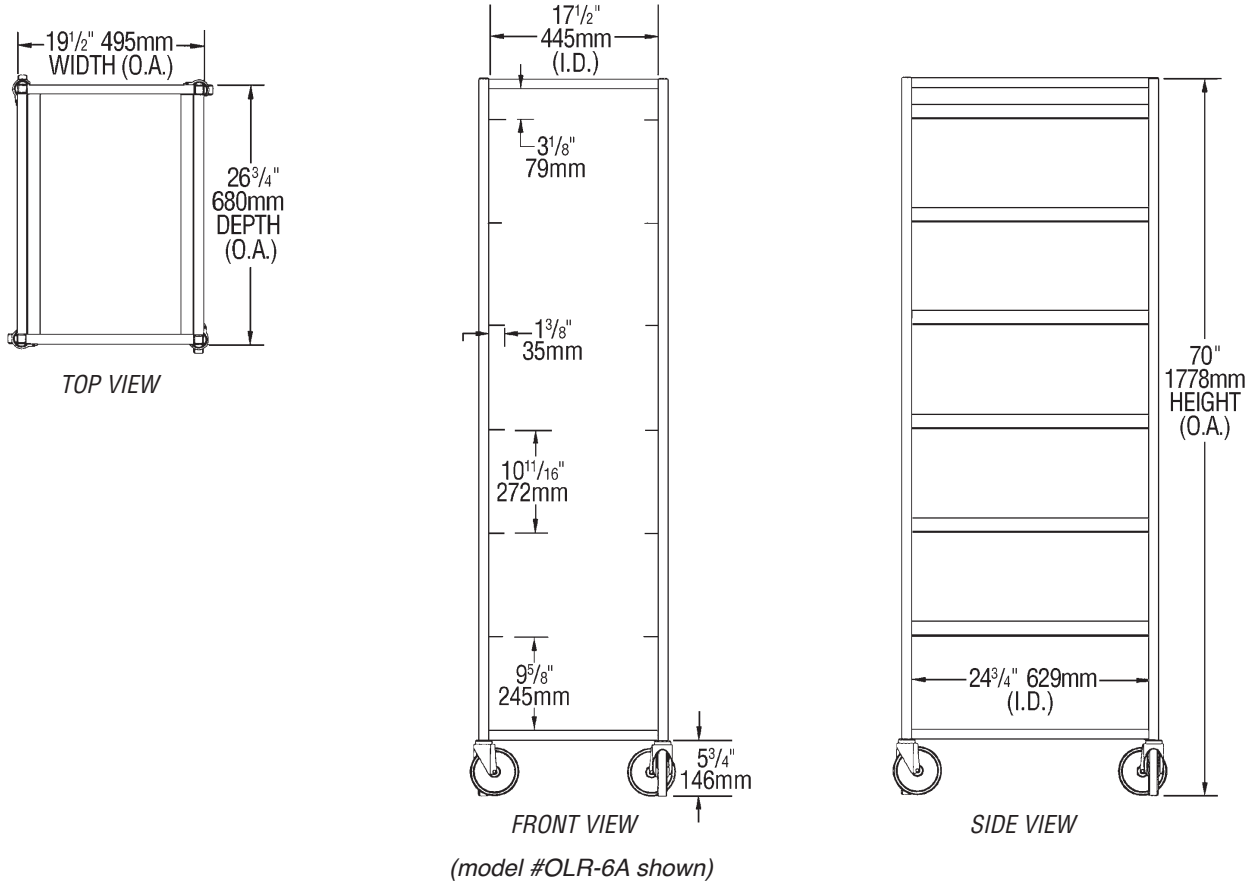

model #	overall dimensions						sliding space		lug capacity	weight	
	width in.	width mm	depth in.	depth mm	height in.	height mm	in.	mm		lbs.	kg
<b>OLR-6A</b>	19 1/2"	495	26 3/4"	680	70"	1778	10 1/16"	272	6	25	11.3
<b>OLR-4A</b>	19 1/2"	495	26 3/4"	680	51"	1295	10 1/16"	272	4	20	9.0
<b>OLR-2A</b>	19"	482	26"	660	31 3/8"	797	10 1/16"	272	2	13	6.4
<b>OLR-1A</b>	15 3/4"	400	26"	660	20 3/8"	524	n/a		1	9	5.4

## Nesting Lug Bin

model #	overall dimensions					
	width in.	width mm	depth in.	depth mm	height in.	height mm
<b>NL1626</b>	15 1/2"	394	26 1/2"	673	8"	203

**EAGLE GROUP**  
 100 Industrial Boulevard, Clayton, DE 19938-8903 USA  
 Phone: 302-653-3000 • Fax: 302-653-2065  
 www.eaglegrp.com

Foodservice Division: Phone 800-441-8440  
 MHC/Retail Display Divisions: Phone 800-637-5100

Printed in U.S.A.  
 ©2014 by Eagle Group

Rev. 06/14

Spec sheets available for viewing, printing or downloading from our online literature library at [www.eaglegrp.com](http://www.eaglegrp.com)

Although every attempt has been made to ensure the accuracy of the information provided, we cannot be held responsible for typographical or printing errors. Information and specifications are subject to change without notice. Please confirm at time of order.