



Profit from the Eagle Advantage®

Specification Sheet

Short Form Specifications

Eagle Panco® Full Size Stationary Can Rack, model FCR-10-9A. All-welded aluminum construction, crossbraced front-to-back and side-to-side. Aluminum angle rack slides secured to frame at a slight angle to allow for gravity feed. Capacity: 162 #10 cans or 216 #5 cans.

Eagle Panco® Full Size Mobile Can Rack, model OCR-10-9A. All-welded aluminum construction, crossbraced front-to-back and side-to-side. Aluminum angle rack slides secured to frame at a slight angle to allow for gravity feed. Furnished with 6"-diameter casters. Capacity: 162 #10 cans or 216 #5 cans.



model #OCR-10-9A
mobile can rack

Options / Accessories

- Casters with locking brakes (for mobile unit only)*
- Perimeter bumpers
- Vertical corner bumpers

* Stationary unit cannot accept caster option.

EAGLE GROUP

100 Industrial Boulevard, Clayton, DE 19938-8903 USA
 Phone: 302-653-3000 • 800-441-8440 • Fax: 302-653-2065
www.eaglegrp.com
www.eaglegrpnews.com
www.eaglegrp.com

For custom configuration or fabrication needs, contact our **SpecFAB® Division**.
Phone: 302-653-3000 • Fax: 302-653-2065 • e-mail: quotes@eaglegrp.com

Item No.:	_____
Project No.:	_____
S.I.S. No.:	_____

Panco® Can Racks — Full Size

MODELS:

- FCR-10-9A
- OCR-10-9A

Design and Construction Features

- All-welded construction. Both racks are constructed of high-strength aluminum sections.
- Frame and supports: square aluminum tubing. Crossbraced front-to-back and side-to-side on top and bottom of unit.
- Rack slides made from aluminum angles, secured to frame at a slight angle for gravity feed.
- Casters on mobile unit: 6" (152mm)-diameter plate casters: two swivel with brake and two rigid casters.
- Stationary unit comes with adjustable feet.
- Provides automatic stock rotation when loaded from rear.
- Shipped assembled.



EG60.15A Rev. 10/23

Spec sheets available for viewing, printing or downloading from our online literature library at our websites

Eagle Foodservice Equipment, Eagle MHC, and SpecFAB® are divisions of Eagle Group. ©2023 by the Eagle Group



Profit from the Eagle Advantage®

Item No.: _____
 Project No.: _____
 S.I.S. No.: _____

Panco® Can Racks—Full Size

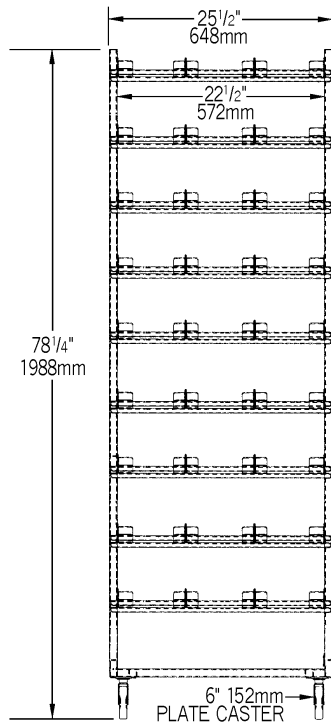

FRONT VIEW

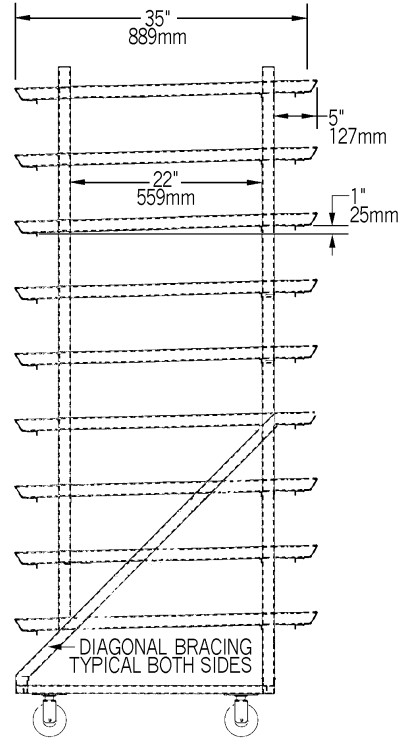

SIDE VIEW

(#OCR-10-9A SHOWN)

model #	description	overall dimensions			sliding space	can capacity		# of tiers high	weight					
		width in.	width mm	depth in.		depth mm	height in.		height mm	#10	#5	lbs.	kg	
FCR-10-9A	full size, stationary	25"	635	35"	889	71"	1803	7 1/2"	191	162	216	9	86	39.0
OCR-10-9A	full size, mobile	25 1/2"	648	35"	889	78 1/4"	1988	7 1/2"	191	162	216	9	125	56.7

EAGLE GROUP
 100 Industrial Boulevard, Clayton, DE 19938-8903 USA
 Phone: 302-653-3000 or 800-441-8440 • Fax: 302-653-2065
 www.eaglegrp.com • www.eaglegrpnews.com • www.eaglehmc.com

Printed in U.S.A.
 ©2023 by Eagle Group

Rev. 10/23

Spec sheets available for viewing, printing or downloading from our online literature library at our websites

Although every attempt has been made to ensure the accuracy of the information provided, we cannot be held responsible for typographical or printing errors. Information and specifications are subject to change without notice. Please confirm at time of order.