



Profit from the Eagle Advantage®

Specification Sheet

Short Form Specifications

Eagle (1800 / 2200 Series) Modular Add-On Bottle Storage Unit, model _____. Top, front and backsplash are heavy gauge type 304 stainless steel. Removable bottle racks hold up to eight 4" diameter bottles. Predrilled mounting holes on both sides. 1½" O.D. galvanized tubular legs with adjustable bullet feet.

Eagle (1800 / 2200 Series) Modular Add-On Insulated Bottle Storage Unit, model _____. Top, front and backsplash are heavy gauge type 304 stainless steel. Foamed-in-place insulation on all sides. Removable bottle racks hold up to eight 4" diameter bottles. Predrilled mounting holes on both sides. 1½" O.D. galvanized tubular legs with adjustable bullet feet.

Eagle (1800 / 2200 Series) Modular Add-On Storage Base Units, model _____. Stainless steel bottom shelf and interior sides. Unit slides underneath the under bar equipment. 1½" O.D. galvanized tubular legs with adjustable bullet feet.



#MA5-18
bottle storage unit



#MAB12
storage base unit

Options / Accessories

Stainless steel leg assemblies

EAGLE GROUP

100 Industrial Boulevard, Clayton, DE 19938-8903 USA
Phone: 302-653-3000 • 800-441-8440 • Fax: 302-653-2065
www.eaglegrp.com
www.eaglegrpnews.com
www.eaglegrp.com

For custom configuration or fabrication needs, contact our **SpecFAB®** Division.
Phone: 302-653-3000 • Fax: 302-653-2065 • e-mail: quotes@eaglegrp.com

Item No.: _____
Project No.: _____
S.I.S. No.: _____

Modular Add-On Bottle Storage Units and Storage Base Units— for 1800 and 2200 Series Units

MODELS:

- MA5-18 MAB12-18
- MA5-22 MAB18-18
- MA5I-18 MAB12-22
- MA5I-22 MAB18-22

Design and Construction Features—All Models

- Bullnose front edge.
- 18 gauge type 304 stainless steel construction.
- 1½" (41mm)-diameter tubular legs.
- Add-on units attach to either end of underbar unit via predrilled mounting holes and pan-head screws.
- Models available for use with both 1800 Series and 2200 Series underbar units.
- Knocked-down gusset/channel and galvanized leg assemblies.

Bottle Storage Units

- Available with or without insulation.
- Uninsulated units feature open bottom.
- Insulated units feature foamed-in-place insulation on all four sides and bottom.
- Removable bottle racks hold up to eight 4" (102mm)-diameter bottles.

Storage Base Units*

- Provides storage underneath underbar units.
- Available in widths of 12" and 18" (305 and 457mm).

*Please note: A Storage Base Unit takes the place of leg assemblies of adjoining MA unit. Leg assemblies of adjoining MA unit must be detached first.



EG40.61B Rev. 08/23

Spec sheets available for viewing, printing or downloading from our online literature library at our websites



Item No.: _____
 Project No.: _____
 S.I.S. No.: _____

Modular Add-On Fillers, Storage Units, and Workboards— for 1800 and 2200 Series Units

Bottle Storage Units

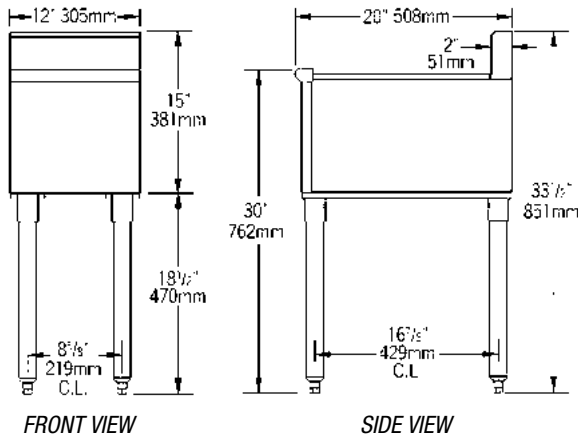

(#MA5-18 shown)

Storage Base Units

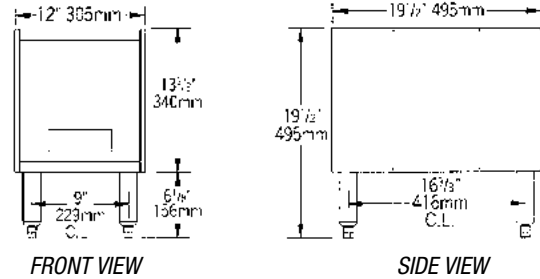

(#MAB12-18 shown)

model #	to fit	front-to-back		side-to-side		weight	
		in.	mm	in.	mm	lbs.	kg
MA5-18	1800 Series units	20"	508	12"	305	17	7.7
MA5-22	2200 Series units	24"	610	12"	305	21	9.5

Insulated Bottle Storage Units:

MA5I-18	1800 Series units	20"	508	12"	305	32	14.5
MA5I-22	2200 Series units	24"	610	12"	305	37	16.8

model #	slides underneath	front-to-back		side-to-side		weight	
		in.	mm	in.	mm	lbs.	kg
MAB12-18	1800 Series units	19 1/2"	495	12"	305	26	11.8
MAB18-18	1800 Series units	19 1/2"	495	18"	457	37	16.8
MAB12-22	2200 Series units	23 1/2"	597	12"	305	30	13.6
MAB18-22	2200 Series units	23 1/2"	597	18"	457	41	18.6

Optional Stainless Steel Leg Kits

add suffix #	description
-SL	stainless steel leg assemblies
-SLF	stainless steel leg assemblies & stainless steel feet
-SLG	stainless steel leg assemblies & stainless steel gussets
-SLGF	stainless steel leg assemblies, stainless steel feet & gussets

EAGLE GROUP
 100 Industrial Boulevard, Clayton, DE 19938-8903 USA
 Phone: 302-653-3000 or 800-441-8440 • Fax: 302-653-2065
 www.eaglegrp.com • www.eaglegrpnews.com • www.eaglehmc.com

Printed in U.S.A.
 ©2023 by Eagle Group
 Rev. 08/23

Spec sheets available for viewing, printing or downloading from our online literature library at our websites

Although every attempt has been made to ensure the accuracy of the information provided, we cannot be held responsible for typographical or printing errors. Information and specifications are subject to change without notice. Please confirm at time of order.