



Profit from the Eagle Advantage®

Specification Sheet

Short Form Specifications

Eagle Spec-Bar® Two Compartment Bar Sink, model _____. Heavy gauge type 304 stainless steel sink bowls, body, legs, leg channels and cross rails. Two 10" x 14" x 9½" deep stainless steel drawn sink bowls with drains and standpipe overflows. T&S splash-mounted faucet. Stainless steel adjustable bullet feet.



#B2-2-19 sink

Options / Accessories

Speed rail

EAGLE GROUP

100 Industrial Boulevard, Clayton, DE 19938-8903 USA
Phone: 302-653-3000 • 800-441-8440 • Fax: 302-653-2065
www.eaglegrp.com
www.eaglemhc.com

For custom configuration or fabrication needs, contact our SpecFAB® Division.
Phone: 302-653-3000 • Fax: 302-653-2065 • e-mail: quotes@eaglegrp.com

Item No.: _____
Project No.: _____
S.I.S. No.: _____

Spec-Bar® Two-Compartment Sinks

MODELS:

- B2-2-19
- B2-2-24

Design and Construction Features

- Body, legs and crossbracing constructed of type 304 stainless steel for strength and corrosion resistance.
- Back, backsplash, sides, bottom, front panel and bowls are constructed of 20 gauge stainless steel.
- Leg channels, legs and crossbracing are 16 gauge stainless steel.
- Legs are 1½" (41mm)-diameter, with stainless steel adjustable bullet feet.
- Sink bowl is 10" x 14" x 9½" (254 x 356 x 241mm) deep.
- Both models have splash-mounted T&S faucet on 4" (102mm) centers, with ½" (13mm) NPT inlet.
- Hot and cold water connections required.
- Drains are 1½" (38mm) I.P.S. threaded with nut and washer.

Certifications / Approvals



AutoQuotes





Item No.: _____
 Project No.: _____
 S.I.S. No.: _____

Spec-Bar® Two-Compartment Sinks

19" (483mm)-wide Sink

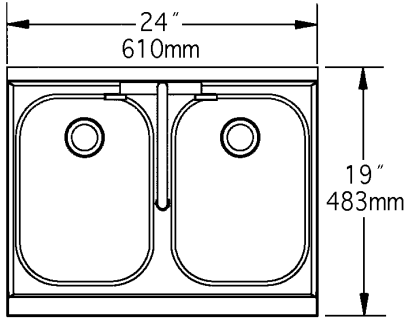

TOP VIEW

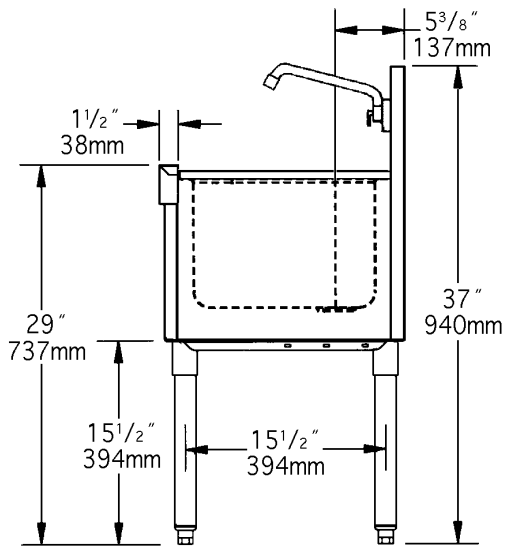

SIDE VIEW

model #	width		length		weight	
	in.	mm	in.	mm	lbs.	kg
B2-2-19	19"	483	24"	610	50	22.7

24" (610mm)-wide Sink

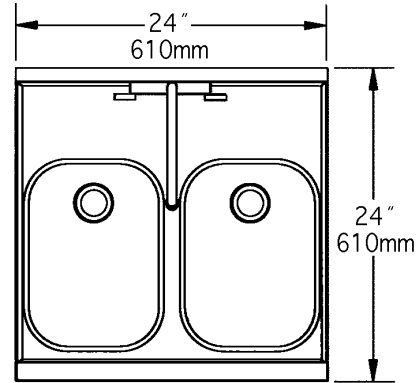

TOP VIEW

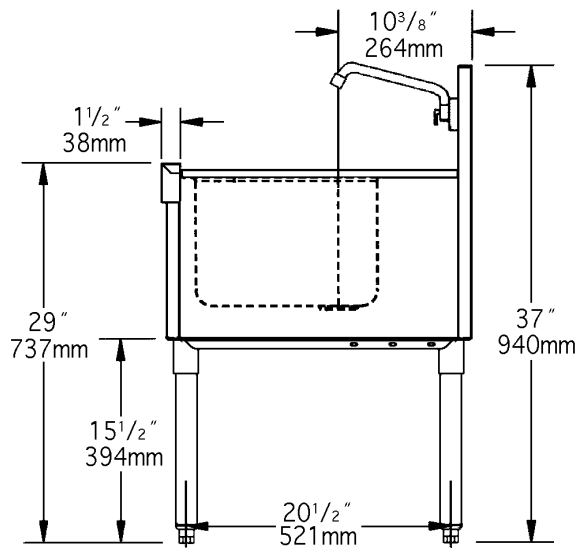

SIDE VIEW

model #	width		length		weight	
	in.	mm	in.	mm	lbs.	kg
B2-2-24	24"	610	24"	610	55	24.9

EAGLE GROUP
 100 Industrial Boulevard, Clayton, DE 19938-8903 USA
 Phone: 302-653-3000 or 800-441-8440 • Fax: 302-653-2065
 www.eaglegrp.com • www.eaglehmc.com

Printed in U.S.A.
 ©2024 by Eagle Group
 Rev. 05/24

Spec sheets available for viewing, printing or downloading from our online literature library at our websites

Although every attempt has been made to ensure the accuracy of the information provided, we cannot be held responsible for typographical or printing errors. Information and specifications are subject to change without notice. Please confirm at time of order.