



Profit from the Eagle Advantage®

Specification Sheet

Short Form Specifications

Eagle 2200 Series Glass Rack Storage Unit, model _____. Offered with Flatboard Top, Recessed Worktop, or Open Top. Front and backsplash to be heavy gauge type 304 stainless steel. Storage units available to accommodate a variety of glass rack sizes, from half-size racks to nominal 20" x 20" racks. 1 1/2" O.D. galvanized tubular legs with adjustable bullet feet.



#FBGR24-22 unit with flatboard top

Options / Accessories

- Stainless steel leg kits (see back page)
- Center shelf

EAGLE GROUP

100 Industrial Boulevard, Clayton, DE 19938-8903 USA
 Phone: 302-653-3000 • 800-441-8440 • Fax: 302-653-2065
www.eaglegrp.com
www.eaglegrpnews.com
www.eaglemhc.com

For custom configuration or fabrication needs, contact our **SpecFAB® Division**.
 Phone: 302-653-3000 • Fax: 302-653-2065 • e-mail: quotes@eaglegrp.com

Item No.:	_____
Project No.:	_____
S.I.S. No.:	_____

2200 Series Glass Rack Storage Units

MODELS:

- | | | |
|---|---|---|
| <input type="checkbox"/> FBGR12-22 | <input type="checkbox"/> FBGR18-22 | <input type="checkbox"/> FBGR24-22 |
| <input type="checkbox"/> WBGR12-22 | <input type="checkbox"/> WBGR18-22 | <input type="checkbox"/> WBGR24-22 |
| <input type="checkbox"/> GR12-22 | <input type="checkbox"/> GR18-22 | <input type="checkbox"/> GR24-22 |

Design and Construction Features

- These units are modular, allowing for custom configurations of underbar equipment using standard components.
- Stainless steel all-welded construction.
- 12", 18, or 24" (305, 457, or 610mm) side-to-side.
- Available with flatboard top, recessed workboard top featuring removable stainless steel perforated insert with 1 1/2" (38mm) stainless steel drain, or open top.
- 24" (610mm)-long units designed to accommodate nominal 20" x 20" (508 x 508mm) full-size glass racks.
- All units feature 1 1/2" (38mm) I.P.S. stainless steel drain on bottom.
- Heavy duty galvanized legs.
- Adjustable plastic bullet feet.
- Optional center shelf available. To order, add suffix "-CS" to model number. Example: FBGR24-22-**CS**



Spec sheets available for viewing, printing or downloading from our online literature library at our websites



Item No.: _____
 Project No.: _____
 S.I.S. No.: _____

2200 Series Glass Rack Storage Units

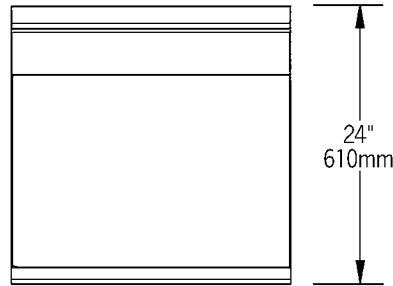

TOP VIEW

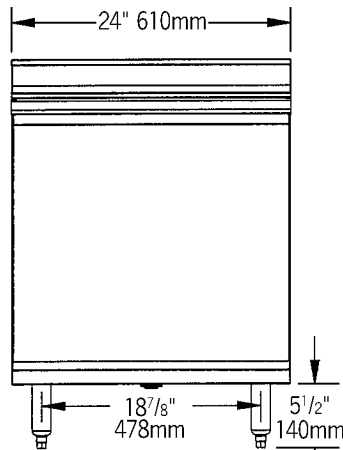

FRONT VIEW

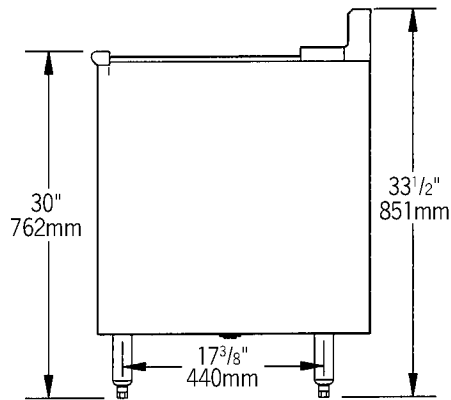

SIDE VIEW

Note: #FBGR24-22 shown

description	width		12" (305mm) side-to-side			18" (457mm) side-to-side			24" (610mm) side-to-side		
	in.	mm	lbs.	kg	model #	lbs.	kg	model #	lbs.	kg	model #
with flatboard top	24"	610	39	17.6	FBGR12-22	53	24.0	FBGR18-22	67	30.4	FBGR24-22
with recessed worktop	24"	610	40	18.1	WBGR12-22	54	24.5	WBGR18-22	68	30.9	WBGR24-22
with open top	23 1/2"	597	36	16.5	GR12-22	47	21.3	GR18-22	49	22.2	GR24-22

Optional Stainless Steel Leg Kits

add suffix #	description
-SL	stainless steel leg assemblies
-SLF	stainless steel leg assemblies & stainless steel feet

EAGLE GROUP
 100 Industrial Boulevard, Clayton, DE 19938-8903 USA
 Phone: 302-653-3000 or 800-441-8440 • Fax: 302-653-2065
 www.eaglegrp.com • www.eaglegrpnews.com • www.eaglehmc.com

Printed in U.S.A.
 ©2022 by Eagle Group

Rev. 12/22

Spec sheets available for viewing, printing or downloading from our online literature library at our websites

Although every attempt has been made to ensure the accuracy of the information provided, we cannot be held responsible for typographical or printing errors. Information and specifications are subject to change without notice. Please confirm at time of order.