



Profit from the Eagle Advantage®

Specification Sheet

Short Form Specifications

Eagle 1800 Series Ice Chests with Sealed-In Cold Plate, model _____ . Top, front, backsplash and ice bin to be heavy gauge type 304 stainless steel. Fabricated ice bin is fully insulated with 1½" drain, and sealed-in 7-circuit cold plate. 1½" O.D. galvanized tubular legs with adjustable bullet feet.



#B30IC-16D-18-7 ice chest with 16" (406mm)-deep ice bin

Options / Accessories

- Stainless steel leg kits (see below)
- Speed rails

Item No.: _____
 Project No.: _____
 S.I.S. No.: _____

1800 Series Ice Chests with Sealed-In Cold Plate

MODELS:

- B2IC-18-7
- B30IC-16D-18-7
- B42IC-12D-18-7
- B2IC-12D-18-7
- B36IC-18-7
- B42IC-16D-18-7
- B2IC-16D-18-7
- B36IC-12D-18-7
- B48IC-18-7
- B30IC-18-7
- B36IC-16D-18-7
- B48IC-12D-18-7
- B30IC-12D-18-7
- B42IC-18-7
- B48IC-16D-18-7

Design and Construction Features

- Bullnose front edge.
- Stainless steel type 304 ice bin, backsplash, front, and sliding ice cover.
- Galvanized ends and back panel.
- Models come with 8", 12" or 16" (203, 305 or 406mm)-deep ice bin.
- 1½" (38mm) drain centered.
- Ice bins are fabricated.
- High-impact, corrosion-resistant, fully-adjustable bullet feet.
- Post-mix cold plates: aluminum casting with seven stainless steel beverage grade tubing circuits. Cold plates are post-mix, mounted flush with interior bottom of ice bin for easy cleaning and maximum efficiency. Drain is ½" (13mm) NPT and centered in ice bin front and back. ¼" (6mm) tube connections provided.
- Packaging: Ice chests with cold plates shipped wood-crated.

Optional Stainless Steel Leg Kits for Ice Chests	
add suffix #	description
-SL	stainless steel leg assemblies
-SLF	stainless steel leg assemblies & stainless steel feet
-SLG	stainless steel leg assemblies & stainless steel gussets
-SLGF	stainless steel leg assemblies, stainless steel feet & gussets

EAGLE GROUP

100 Industrial Boulevard, Clayton, DE 19938-8903 USA
 Phone: 302-653-3000 • 800-441-8440 • Fax: 302-653-2065
www.eaglegrp.com
www.eaglemhc.com

For custom configuration or fabrication needs, contact our SpecFAB® Division.
 Phone: 302-653-3000 • Fax: 302-653-2065 • e-mail: quotes@eaglegrp.com



EG40.04B Rev. 04/24

Spec sheets available for viewing, printing or downloading from our online literature library at our websites



Item No.: _____
 Project No.: _____
 S.I.S. No.: _____

1800 Series Ice Chests with Sealed-In Cold Plate

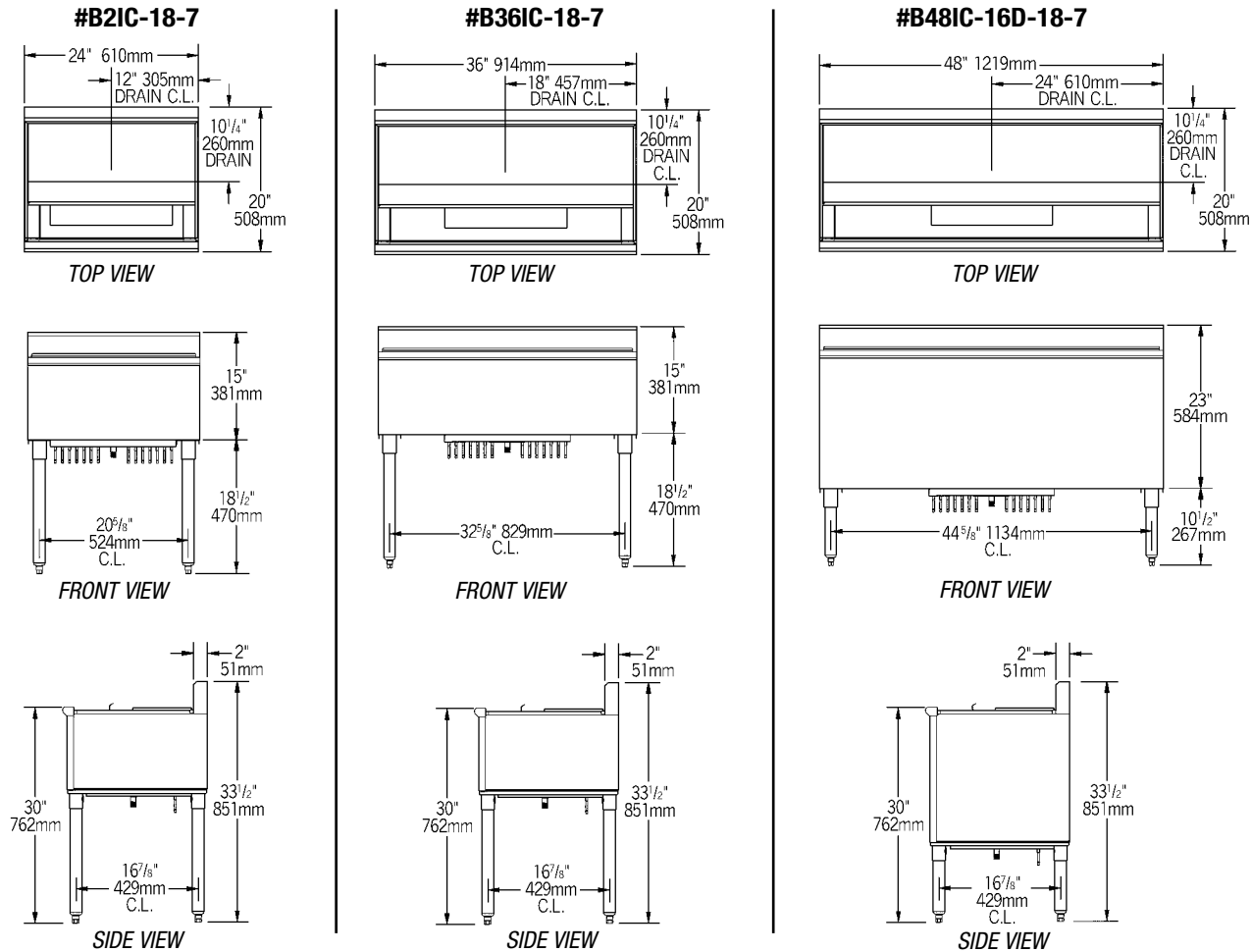

model #	width x length		weight		ice bin depth		ice capacity	
	in.	mm	lbs.	kg	in.	mm	lbs.	kg
B2IC-18-7	20" x 24"	495 x 610	160	72.6	8"	203	37	16.8
B2IC-12D-18-7	20" x 24"	495 x 610	180	81.7	12"	305	55	24.9
B2IC-16D-18-7	20" x 24"	495 x 610	190	86.2	16"	406	73	33.1
B30IC-18-7	20" x 30"	495 x 762	174	78.9	8"	203	48	21.8
B30IC-12D-18-7	20" x 30"	495 x 762	184	83.5	12"	305	71	32.2
B30IC-16D-18-7	20" x 30"	495 x 762	194	88.0	16"	406	95	43.1
B36IC-18-7	20" x 36"	495 x 914	176	79.8	8"	203	59	26.8
B36IC-12D-18-7	20" x 36"	495 x 914	187	84.8	12"	305	88	39.9
B36IC-16D-18-7	20" x 36"	495 x 914	198	89.8	16"	406	117	53.1
B42IC-18-7	20" x 42"	495 x 1067	227	103.0	8"	203	70	31.8
B42IC-12D-18-7	20" x 42"	495 x 1067	232	105.2	12"	305	105	47.6
B42IC-16D-18-7	20" x 42"	495 x 1067	245	111.1	16"	406	140	63.5
B48IC-18-7	20" x 48"	495 x 1219	233	105.7	8"	203	81	36.7
B48IC-12D-18-7	20" x 48"	495 x 1219	243	110.2	12"	305	121	54.9
B48IC-16D-18-7	20" x 48"	495 x 1219	251	113.9	16"	406	162	73.5

EAGLE GROUP
 100 Industrial Boulevard, Clayton, DE 19938-8903 USA
 Phone: 302-653-3000 or 800-441-8440 • Fax: 302-653-2065
 www.eaglegrp.com • www.eaglehmc.com

Printed in U.S.A.
 ©2024 by Eagle Group
 Rev. 04/24

Spec sheets available for viewing, printing or downloading from our online literature library at our websites

Although every attempt has been made to ensure the accuracy of the information provided, we cannot be held responsible for typographical or printing errors. Information and specifications are subject to change without notice. Please confirm at time of order.