



Profit from the Eagle Advantage®

Specification Sheet

Short Form Specifications

Eagle Director's Choice® Tray Platform Unit, model DCS2-TPU. Top to be 16/304 stainless steel turned down on all sides. 1½" square type 304 stainless steel all-welded tubular base. Removable solid bottom panel will store up to 200 trays, and furnished with ten nylon silverware cylinders. Fully mobile with 5" poly casters, two with brake.



#DCS2-TPU tray platform unit

Item No.:	_____
Project No.:	_____
S.I.S. No.:	_____

Director's Choice® Tray Platform Unit

MODEL:

DCS2-TPU

Design and Construction Features

- Welded 1½" (38mm) type 304 stainless steel square tubular base construction.
- Open frame features 1½" (38mm) square stainless steel tubing.
- Fully mobile - standard 5" (127mm) swivel casters, two with brake.
- Removable two-section undershelf.
- Includes ten white dishwasher-safe nylon silverware cylinders.
- Holds up to 200 trays.
- 24" (610mm) front-to-back, 36" (914mm) side-to-side.
- 39" (991mm) overall height.

Options / Accessories *

* This is a freestanding unit not designed to lock together with other units. Optional laminates, front/end panels, tray slides, workboards, and serving shelves do not apply.

EAGLE GROUP

100 Industrial Boulevard, Clayton, DE 19938-8903 USA
Phone: 302-653-3000 • 800-441-8440 • Fax: 302-653-2065
www.eaglegrp.com
www.eaglegrpnews.com
www.eaglemhc.com

For custom configuration or fabrication needs, contact our SpecFAB® Division.
Phone: 302-653-3000 • Fax: 302-653-2065 • e-mail: quotes@eaglegrp.com



EG33.21 Rev. 07/23

Spec sheets available for viewing, printing or downloading from our online literature library at our websites

Eagle Foodservice Equipment, Eagle MHC, and SpecFAB® are divisions of Eagle Group. ©2023 by the Eagle Group



Item No.: _____
 Project No.: _____
 S.I.S. No.: _____

Director's Choice® Tray Platform Unit

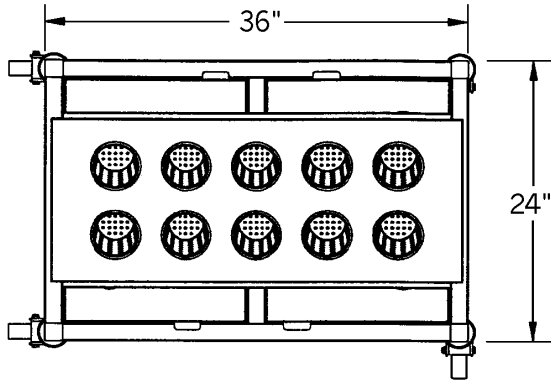

TOP VIEW

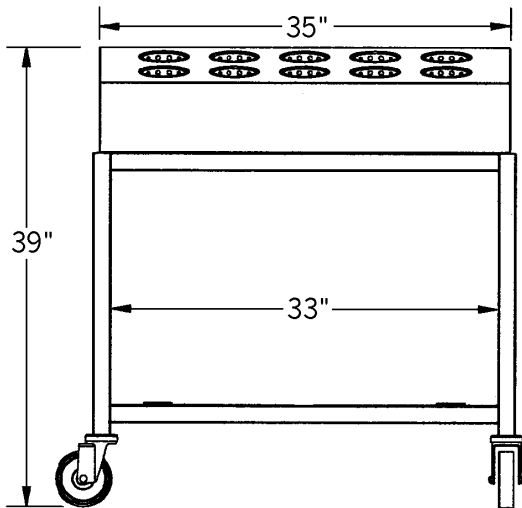

FRONT VIEW

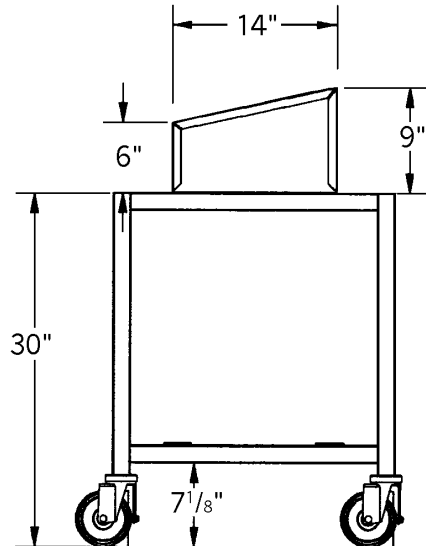

SIDE VIEW

model #	width		length		weight	
	in.	mm	in.	mm	lbs.	kg
DCS2-TPU	24"	610	36"	914	250	113.4

EAGLE GROUP
 100 Industrial Boulevard, Clayton, DE 19938-8903 USA
 Phone: 302-653-3000 or 800-441-8440 • Fax: 302-653-2065
 www.eaglegrp.com • www.eaglegrpnews.com • www.eaglegrp.com

Printed in U.S.A.
 ©2023 by Eagle Group
 Rev. 07/23

Spec sheets available for viewing, printing or downloading from our online literature library at our websites

Although every attempt has been made to ensure the accuracy of the information provided, we cannot be held responsible for typographical or printing errors. Information and specifications are subject to change without notice. Please confirm at time of order.