



Profit from the Eagle Advantage®

Specification Sheet

Short Form Specifications

Eagle Director's Choice® Hot Food Service Counter, model _____ . Top to be 16/304 stainless steel turned down on all sides. Fully welded 1½" square stainless steel tubular frame with type 304 aprons on all sides. Sealed wells accept 12" x 20" food pans, and feature individual thermostatic controls. Single or three phase, wired to a 10' cord and plug. Fully mobile with 5" poly tread casters, half with brake.



"U" shaped unit



"L" shaped unit

Options / Accessories

- End panels (in lieu of aprons)
- Front panels (in lieu of aprons)
- Stainless steel tray slide*
- Work shelf**
- Plate shelves
- Convenience outlets
- Bullet feet (in lieu of casters)
- Removable undershelves

* Available in solid ribbed, square tubular or round tubular. For front, rear, or ends. See spec sheet #EG33.07A

** Available in hardwood, stainless steel, poly, or Richlite®. For front, rear, or ends. See spec sheet #EG33.07A

EAGLE GROUP

100 Industrial Boulevard, Clayton, DE 19938-8903 USA
Phone: 302-653-3000 • 800-441-8440 • Fax: 302-653-2065
www.eaglegrp.com
www.eaglehmc.com

For custom configuration or fabrication needs, contact our SpecFAB® Division.
Phone: 302-653-3000 • Fax: 302-653-2065 • e-mail: quotes@eaglegrp.com

Item No.: _____
 Project No.: _____
 S.I.S. No.: _____

Director's Choice® Hot Food Service Counters

MODELS:

- DCS3-TMU-A
- DCS3-TMU-B
- DCS3-TMU-B-3
- DCS3-TMU-C
- DCS3-TMU-C-3
- DCS4-TMU-B
- DCS4-TMU-B-3
- DCS4-TMU-C
- DCS4-TMU-C-3
- DCS5-TMU-B
- DCS5-TMU-B-3
- DCS5-TMU-C
- DCS5-TMU-C-3
- DCS6-TMU-B
- DCS6-TMU-B-3
- DCS6-TMU-C
- DCS6-TMU-C-3
- DCS4-TMLL-B
- DCS4-TMLL-B-3
- DCS4-TMLL-C
- DCS4-TMLL-C-3
- DCS4-TMLR-B
- DCS4-TMLR-B-3
- DCS4-TMLR-C
- DCS4-TMLR-C-3

Design and Construction Features—All Models

- Top is constructed of 16 gauge type 304 stainless steel, welded and polished.
- Welded 1½" (38mm) type 304 stainless steel square tubular base construction.
- Fully-insulated heat wells are sealed, accept 12" x 20" (305 x 508mm) food pans, and feature individual thermostat controls.
- Single or three phase, wired to a 10' (3048mm) cord and plug.
- Fully mobile - standard 5" (127mm) poly tread casters.
- ¾" (19mm) drain.

"U"-Shaped Models

- Includes eight 5" (127mm)-diameter casters, four with brake.

"L"-Shaped Models

- Includes five 5" (127mm)-diameter casters, three with brake.

Certifications / Approvals



EG33.20 Rev. 11/23

Spec sheets available for viewing, printing or downloading from our online literature library at our websites

Eagle Foodservice Equipment, Eagle MHC, and SpecFAB® are divisions of Eagle Group. ©2023 by the Eagle Group



Profit from the Eagle Advantage®

Item No.: _____
 Project No.: _____
 S.I.S. No.: _____

Director's Choice® Hot Food Service Counters

Model number with suffix **-A** = 120V unit with 1200W per well.
 Model number with suffix **-B** = 208V/240V unit with 900W/1200W per well.
 Model number with suffix **-C** = 208V/240V unit with 1200W/1600W per well.

"U" Shaped Units

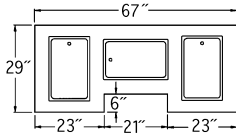

#DCS3-TMU

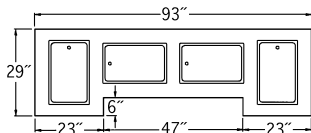

#DCS4-TMU

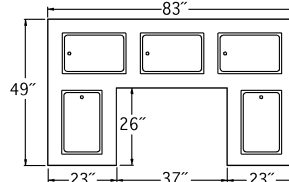

#DCS5-TMU

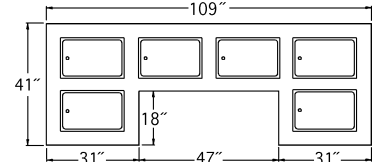

#DCS6-TMU

# of wells	length		volts	watts	amps	SINGLE-PHASE		THREE-PHASE		
	in.	mm				NEMA plug	model #	amps	NEMA plug	model #
3	50"	1270	120V	3600W	30.0A	5-50P	DCS3-TMU-A	-	-	n/a
3	50"	1270	208/240V	2700/3600W	13.0/15.0A	5-20P	DCS3-TMU-B	7.5/8.7A	15-20P	DCS3-TMU-B-3
3	50"	1270	208/240V	3600/4800W	17.3/20.0A	5-30P	DCS3-TMU-C	10.0/11.6A	15-20P	DCS3-TMU-C-3
4	64"	1626	208/240V	3600/4800W	17.3/20.0A	5-30P	DCS4-TMU-B	11.5/13.2A	15-20P	DCS4-TMU-B-3
4	64"	1626	208/240V	4800/6400W	23.1/26.7A	5-30P/5-50P	DCS4-TMU-C	15.3/17.7A	15-20P/15-30P	DCS4-TMU-C-3
5	78"	1981	208/240V	4500/6000W	21.6/25.0A	5-30P/5-50P	DCS5-TMU-B	15.0/17.3A	15-20P/15-30P	DCS5-TMU-B-3
5	78"	1981	208/240V	6000/8000W	28.8/33.3A	5-50P	DCS5-TMU-C	20.0/23.1A	15-30P/15-30P	DCS5-TMU-C-3
6	96"	2438	208/240V	5400/7200W	26.0/30.0A	5-50P	DCS6-TMU-B	15.0/17.3A	15-20P/15-30P	DCS6-TMU-B-3
6	96"	2438	208/240V	7200/9600W	34.6/40.0A	5-50P	DCS6-TMU-C	20.0/23.1A	15-30P/15-30P	DCS6-TMU-C-3

"L" Shaped Units

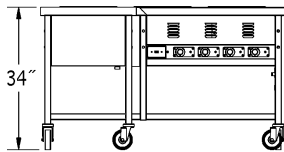

FRONT VIEW OF #DCS4-TMLL
(OPERATOR'S SIDE)

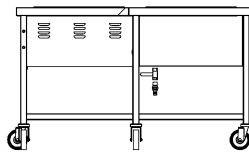

SIDE VIEW OF #DCS4-TMLL

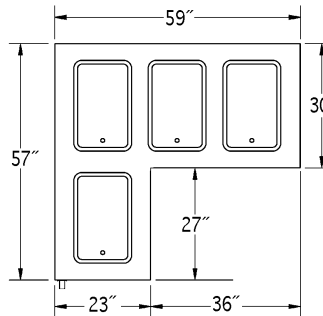

TOP VIEW OF #DCS4-TMLL

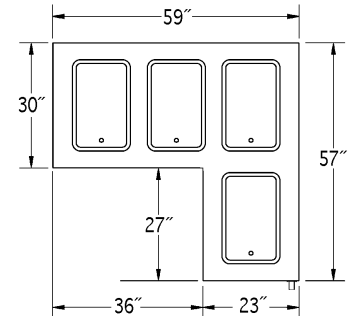

TOP VIEW OF #DCS4-TMLR

# of wells	length		volts	watts	amps	SINGLE-PHASE		THREE-PHASE		
	in.	mm				NEMA plug	model #	amps	NEMA plug	model #
4	64"	1626	208/240V	3600/4800W	17.3/20.0A	5-30P	DCS4-TMLL-B	11.5/13.2A	15-20P	DCS4-TMLL-B-3
4	64"	1626	208/240V	4800/6400W	23.1/26.7A	5-30P/5-50P	DCS4-TMLL-C	15.3/17.7A	15-20P/15-30P	DCS4-TMLL-C-3
4	64"	1626	208/240V	3600/4800W	17.3/20.0A	5-30P	DCS4-TMLR-B	11.5/13.2A	15-20P	DCS4-TMLR-B-3
4	64"	1626	208/240V	4800/6400W	23.1/26.7A	5-30P/5-50P	DCS4-TMLR-C	15.3/17.7A	15-20P/15-30P	DCS4-TMLR-C-3

"TMLL" indicates fourth well at left, standing at operator's side of unit.
 "TMLR" indicates fourth well at right, standing at operator's side of unit.

EAGLE GROUP
 100 Industrial Boulevard, Clayton, DE 19938-8903 USA
 Phone: 302-653-3000 or 800-441-8440 • Fax: 302-653-2065
 www.eaglegrp.com • www.eaglehmc.com

Printed in U.S.A.
 ©2023 by Eagle Group

Rev. 11/23

Spec sheets available for viewing, printing or downloading from our online literature library at our websites

Although every attempt has been made to ensure the accuracy of the information provided, we cannot be held responsible for typographical or printing errors. Information and specifications are subject to change without notice. Please confirm at time of order.