



Profit from the Eagle Advantage®

# Specification Sheet

## Short Form Specifications

Eagle Director's Choice® Beverage Unit, model \_\_\_\_\_. Top to be 16/304 stainless steel turned down on all sides, with hat channel reinforcement. 1½" square type 304 stainless steel all-welded tubular base. Quick release spring loaded docking device keeps adjoining units together. Urn trough to be 2" deep x 4½" wide, and sloped to a 1" drain. Stainless steel trough cover features louvered "anti-splash" design. Fully mobile with 5" poly tread casters, two with brake. Standard laminate front panel is holly berry red (Wilsonart® #D307-60).



single-urn trough beverage unit shown with optional tray slide and laminate end panels

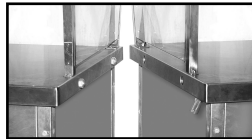

exclusive docking device joins units together without the use of tools

## Options / Accessories

- Laminated end panels
- Stainless steel end panels
- Stainless steel front panel
- Stainless steel tray slide\*
- Work shelf\*\*
- Specify laminate \_\_\_\_\_
- Removable undershelf
- Custom options

\* Available in solid ribbed, square tubular or round tubular. For front, rear, or ends.

\*\* Available in hardwood, stainless steel, poly, or Richlite®. For front, rear, or ends.

## EAGLE GROUP

100 Industrial Boulevard, Clayton, DE 19938-8903 USA  
Phone: 302-653-3000 • 800-441-8440 • Fax: 302-653-2065  
www.eaglegrp.com  
www.eaglegrpnews.com  
www.eaglemh.com

For custom configuration or fabrication needs, contact our SpecFAB® Division.  
Phone: 302-653-3000 • Fax: 302-653-2065 • e-mail: quotes@eaglegrp.com

Item No.: \_\_\_\_\_  
 Project No.: \_\_\_\_\_  
 S.I.S. No.: \_\_\_\_\_

# Director's Choice® Beverage Units

## MODELS:

- DCS2-BSU
- DCS3-BSU
- DCS4-BSU
- DCS5-BSU
- DCS2-BDU
- DCS3-BDU
- DCS4-BDU
- DCS5-BDU

## Design and Construction Features

- 30" (762mm)-wide heavy gauge type 304 stainless steel solid top is reinforced via hat channels, welded, die-formed, polished, and features 4½" (114mm)-wide, 2" (51mm)-deep urn troughs with anti-splash grate.
- Trough cover is sectional to fit in dishwasher for sanitation.
- Trough is sloped to a 1" (25mm)-diameter drain to operator's left.
- Welded 1½" (38mm) type 304 stainless steel square tubular base construction.
- Open-base frame features type 304 stainless steel apron on operator's side.
- Three working heights available—see Catalog Sheet EG33.07A:
  - 34" (864mm) standard working height complies with ADA guidelines for accessibility standards.
  - 30" (762mm) for middle schools.
  - 28" (711mm) low profile for elementary schools and nursing/healthcare facilities.
- Tray slide heights available—see Catalog Sheet EG33.07A:
  - 31" (787mm) standard height for high schools.
  - 27" (686mm) standard height for middle schools.
  - 25" (635mm) height for elementary schools and nursing/healthcare facilities.
- Fully mobile – standard 5" (127mm)-diameter poly tread casters, two with brake (brake casters on server side).
- Standard front holly berry red (Wilsonart® D307-60) laminate mounted on 18 gauge galvanized subpanel.
- 1" (25mm)-diameter stainless steel drain provided with PVC drain material.
- Drain fitting on operator's left.
- All units are predrilled to accommodate optional accessories, including tray shelves, work shelves, and removable undershelves. See Catalog Sheet EG33.07A.

## Certifications / Approvals



AutoQuotes



EG33.06 Rev. 07/23

Spec sheets available for viewing, printing or downloading from our online literature library at our websites



Item No.: \_\_\_\_\_  
 Project No.: \_\_\_\_\_  
 S.I.S. No.: \_\_\_\_\_

# Director's Choice® Beverage Units

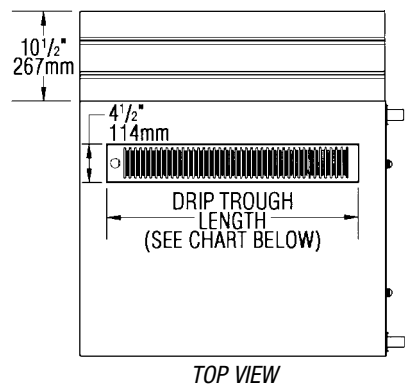

Please note: Single-urn trough model shown with optional tray slide.

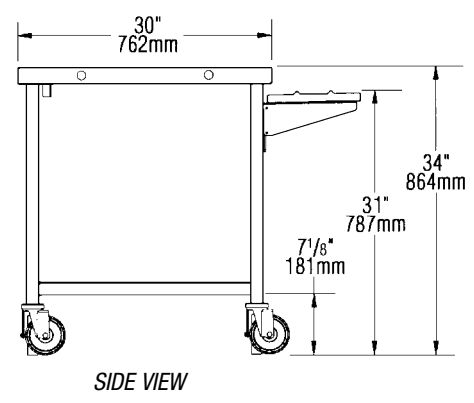
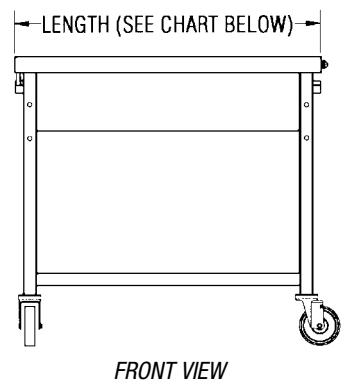

Single-Urn Trough model #	Double-Urn Trough model #	length		urn trough length		weight	
		in.	mm	in.	mm	lbs.	kg
DCS2-BSU	DCS2-BDU	36"	914	28½"	724	150	68.0
DCS3-BSU	DCS3-BDU	50"	1270	42¾"	1086	180	81.6
DCS4-BSU	DCS4-BDU	64"	1626	57½"	1451	220	99.8
DCS5-BSU	DCS5-BDU	78"	1981	71½"	1816	270	122.5

Optional laminate end panels available. To order, add suffix "-LEP" to model number. Example: DSC3-BSU-LEP  
 Optional stainless steel front panel in lieu of laminate front panel available. To order, add suffix "-S" to model number. Example: DCS3-BSU-S  
 Optional stainless steel end panels available. To order, add suffix "-SEP" to model number. Example: DSC3-BSU-S-SEP

**EAGLE GROUP**  
 100 Industrial Boulevard, Clayton, DE 19938-8903 USA  
 Phone: 302-653-3000 or 800-441-8440 • Fax: 302-653-2065  
 www.eaglegrp.com • www.eaglegrpnews.com • www.eaglehmc.com

Printed in U.S.A.  
 ©2023 by Eagle Group  
 Rev. 07/23

**Spec sheets available for viewing, printing or downloading from our online literature library at our websites**

Although every attempt has been made to ensure the accuracy of the information provided, we cannot be held responsible for typographical or printing errors. Information and specifications are subject to change without notice. Please confirm at time of order.