



Profit from the Eagle Advantage®

Specification Sheet

Short Form Specifications

Eagle Hot Food Tables, open base design, model _____ . Top and body are heavy gauge type 430 stainless steel, with top and water pan removable for cleaning or replacement. All top openings sized to accommodate 12" x 20" steam table pans. Water pan is all-welded 20/304 stainless steel, complete with 1 1/2" diameter brass drain. Burners are straight flow tubular type with energy-saving design for quick starts (15,000 BTU burner on 2- and 3-well openings, 30,000 BTU burner on 4-, 5-, and 8-well openings) and pressure regulator. 1/2" NPT pipe connection on right side. Polyethylene 8"-wide cutting board and stainless steel dish shelf provided. Legs are 1 5/8" O.D. galvanized tubing with galvanized adjustable undershelf, and adjustable stainless steel bullet feet.



#AWT3-NG unit with optional Flex-Master® Overshelf System*

Options / Accessories

- Bolted-in undershelf
- Tray slides/shelf
- Rolltop cover
- Serving shelf
- Top adapters
- Food pans/insets
- AutoFill® automatic water fill system

* See Catalog Sheet #EG30.18 for more information on Flex-Master® overshelves

EAGLE GROUP

100 Industrial Boulevard, Clayton, DE 19938-8903 USA
Phone: 302-653-3000 • 800-441-8440 • Fax: 302-653-2065
www.eaglegrp.com
www.eaglegrpnews.com
www.eaglemhc.com

For custom configuration or fabrication needs, contact our SpecFAB® Division.
Phone: 302-653-3000 • Fax: 302-653-2065 • e-mail: quotes@eaglegrp.com

Item No.:	_____
Project No.:	_____
S.I.S. No.:	_____

Gas Water Bath Steam Tables—Open Base

MODELS:

- | | | | |
|------------------------------------|------------------------------------|--------------------------------------|---------------------------------|
| <input type="checkbox"/> AWT2-NG | <input type="checkbox"/> AWT5-NG | <input type="checkbox"/> ASWTP4-NG | <input type="checkbox"/> 305171 |
| <input type="checkbox"/> AWT2-NG | <input type="checkbox"/> AWT5-NG | <input type="checkbox"/> ASWT4-NG-1 | <input type="checkbox"/> 305172 |
| <input type="checkbox"/> AWT3-NG | <input type="checkbox"/> ASWT2-NG | <input type="checkbox"/> ASWTP4-NG-1 | <input type="checkbox"/> 305259 |
| <input type="checkbox"/> AWT3-NG | <input type="checkbox"/> ASWTP2-NG | <input type="checkbox"/> ASWT5-NG | <input type="checkbox"/> 305313 |
| <input type="checkbox"/> AWT4-NG | <input type="checkbox"/> ASWT3-NG | <input type="checkbox"/> ASWTP5-NG | <input type="checkbox"/> 305314 |
| <input type="checkbox"/> AWT4-NG | <input type="checkbox"/> ASWTP3-NG | <input type="checkbox"/> 305169 | <input type="checkbox"/> 305315 |
| <input type="checkbox"/> AWT4-NG-1 | <input type="checkbox"/> ASWT4-NG | <input type="checkbox"/> 305170 | <input type="checkbox"/> 305316 |
| <input type="checkbox"/> AWT4-NG-1 | | | |

Models listed are units with natural gas. For units with liquid propane, replace suffix "-NG" with "-LP". Example: AWT3-LP

Construction

- Table body and top constructed of highly polished 20 gauge 430 series stainless steel.
- Top has openings sized to accommodate 12" x 20" (305 x 508mm) food pans.
- Poly cutting board 8" (203mm) wide and 1/2" (32mm) thick is mounted on stainless steel brackets located on control side of unit.
- Cutting board and stainless steel dish shelf are standard on all models.
- Legs are 1 5/8" (42mm) O.D. galvanized tubing fitted with adjustable stainless steel bullet feet.
- Undershelf constructed of galvanized steel.

Water pan

- 20 gauge 304 stainless steel all-seamless construction, complete with 1 1/2" (38mm) diameter brass drain.

Burner assembly

- Constructed of aluminized steel with straight flow energy-saving design for quick startup.
- 15,000 BTU burner on 2- and 3-opening models; 30,000 BTU burner on 4-, 5-, and 8-opening models.
- 1/2" (13mm) N.P.T. pipe connection is on right side.
- Available in LP gas.

Optional safety pilot

- AGA design certified, complete with high performance cast aluminum automatic shut-off valve and pressure regulator.

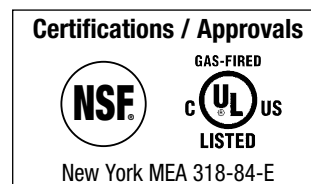



Item No.: _____
 Project No.: _____
 S.I.S. No.: _____

Gas Water Bath Steam Tables—Open Base

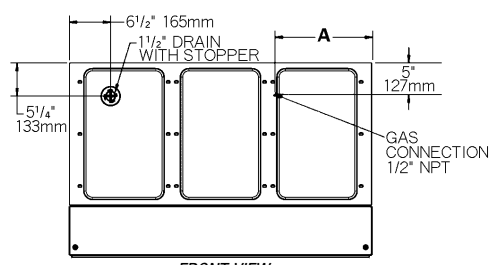

Dimension A	
2 well	8" (203mm)
3 well	15 1/2" (294mm)
4 well	15 1/2" (294mm)
5 well	23" (584mm)

Note: models #AWT4-NG-1 and AWTP4-NG-1 are provided with (2) 12" x 20", (2) 6 1/2" round openings, and (4) 8 1/2" round openings. See "8-well" line art below.

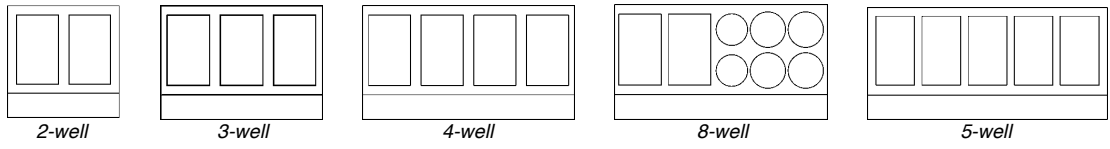
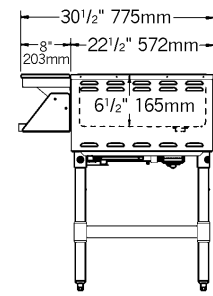
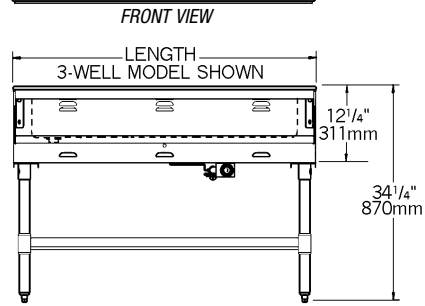

description	# of top openings	length		WITH GALVANIZED LEGS AND UNDERSHELF		WITH STAINLESS STEEL LEGS AND UNDERSHELF		REPLACEMENT TOP	REPLACEMENT WATER PAN
		in.	mm	model #	weight lbs. kg	model #	weight lbs. kg		
natural gas ("NG")	2	33"	838	AWT2-NG	98 44.5	ASWT2-NG	98 44.5	305169	305315
NG w/safety pilot	2	33"	838	AWTP2-NG	98 44.5	ASWTP2-NG	98 44.5	305169	305315
natural gas ("NG")	3	48"	1219	AWT3-NG	132 59.9	ASWT3-NG	132 59.9	305170	305313
NG w/safety pilot	3	48"	1219	AWTP3-NG	132 59.9	ASWTP3-NG	132 59.9	305170	305313
natural gas ("NG")	4	63 1/2"	1613	AWT4-NG	198 89.8	ASWT4-NG	198 89.8	305171	305314
NG w/safety pilot	4	63 1/2"	1613	AWTP4-NG	198 89.8	ASWTP4-NG	198 89.8	305171	305314
natural gas ("NG")	8	63 1/2"	1613	AWT4-NG-1	198 89.8	ASWT4-NG-1	198 89.8	305259	305314
NG w/safety pilot	8	63 1/2"	1613	AWTP4-NG-1	198 89.8	ASWTP4-NG-1	198 89.8	305259	305314
natural gas ("NG")	5	79"	2007	AWT5-NG	244 110.7	ASWT5-NG	244 110.7	305172	305316
NG w/safety pilot	5	79"	2007	AWTP5-NG	244 110.7	ASWTP5-NG	244 110.7	305172	305316

To order units with liquid propane in place of natural gas, replace suffix "-NG" with "-LP". Example: AWT3-LP

FLEX-MASTER® Overshelf Kits

Both kits include two 16/304 overshelves and four 30" (762mm) posts. Add suffix specified to order kit (example: DHT2-120-FMU), or design your own using standard components from EG30.18.

description	add suffix
10" (254mm) overshelves	-FM
15" (381mm) overshelves, plus one ladle rack	-FMU

EAGLE GROUP
 100 Industrial Boulevard, Clayton, DE 19938-8903 USA
 Phone: 302-653-3000 or 800-441-8440 • Fax: 302-653-2065
 www.eaglegrp.com • www.eaglegrpnews.com • www.eaglehmc.com

Printed in U.S.A.
 ©2023 by Eagle Group
 Rev. 02/23

Spec sheets available for viewing, printing or downloading from our online literature library at our websites

Although every attempt has been made to ensure the accuracy of the information provided, we cannot be held responsible for typographical or printing errors. Information and specifications are subject to change without notice. Please confirm at time of order.