



Profit from the Eagle Advantage®

Specification Sheet

Short Form Specifications

Eagle Spec-Master® FFN Series Flush Front Sink, model _____ . Drainboards and sink bowl partitions, front panel, sink bowl exterior wrapper, and backsplash to be 14 gauge type 304 stainless steel. Sinks compartments to have 3/4" inside radii. 1 1/2" stainless steel tubular legs with stainless steel gussets, crossrails, and stainless steel adjustable bullet feet.



three-compartment sink

Options / Accessories

- Faucet
- Prerinse Faucet
- Lever drain
- Lever drain with overflow
- Twist handle drains
- Overflow hole
- Undershelf

Mechanical:

- Faucet holes are 1 1/2" (29mm) punched on 8" (203mm) centers. Two sets of faucets holes featured on sinks with three compartments.
- Water supply is 1/2" (13mm) NPS for hot and cold lines.

EAGLE GROUP
100 Industrial Boulevard, Clayton, DE 19938-8903 USA
Phone: 302-653-3000 • Fax: 302-653-2065
www.eaglegrp.com

Foodservice Division: Phone 800-441-8440
MHC/Retail Display Divisions: Phone 800-637-5100

For custom configuration or fabrication needs, contact our **SpecFAB® Division**.
 Phone: 302-653-3000 • Fax: 302-653-2065 • e-mail: quotes@eaglegrp.com

Item No.: _____
 Project No.: _____
 S.I.S. No.: _____

Spec-Master® FFN Series Flush Front Sinks

MODELS:

- FFN2736-2-24-14/3
- FFN2736-2-30-14/3
- FFN2740-2-24-14/3
- FFN2740-2-30-14/3
- FFN2748-2-24-14/3
- FFN2748-2-30-14/3
- FFN2760-2-24-14/3
- FFN2760-2-30-14/3
- FFN2754-3-24-14/3
- FFN2754-3-30-14/3
- FFN2760-3-24-14/3
- FFN2760-3-30-14/3
- FFN2772-3-24-14/3
- FFN2772-3-30-14/3
- FFN2790-3-24-14/3
- FFN2790-3-30-14/3

Top

- Full front and backsplash are 14 gauge stainless steel.
- 14 gauge double drainboards and rolled rims.
- 10" (254mm)-high backsplash with 1" (25mm) downturn at rear.

Base

- All-welded base constructed of 1 1/2" (41mm)-diameter tubular stainless steel.
- Legs* are located directly under sink bowls, providing increased stability and maximum weight support.
- Stainless steel crossbracing on all four sides.
- Adjustable stainless steel bullet feet.

Sinks

- Exterior wrapper is 14 gauge type 304 stainless steel.
- 14 gauge stainless steel sink bowl partitions.
- Sink compartments feature 3/4" (19mm) covered inside radii.
- 14" (356mm) water level.
- Basket-type waste drain fits 3 1/2" (89mm) opening and features 1 1/2" (38mm) outlet.
- Swirl-away drainage.

* For units with 30" (762mm)-long drainboards, additional legs are located under each drainboard.



EG20.54 Rev. 05/19

Spec sheets available for viewing, printing or downloading from our online literature library at www.eaglegrp.com



Profit from the Eagle Advantage®

Item No.: _____
 Project No.: _____
 S.I.S. No.: _____

Spec-Master® FFN Series Flush Front Sinks

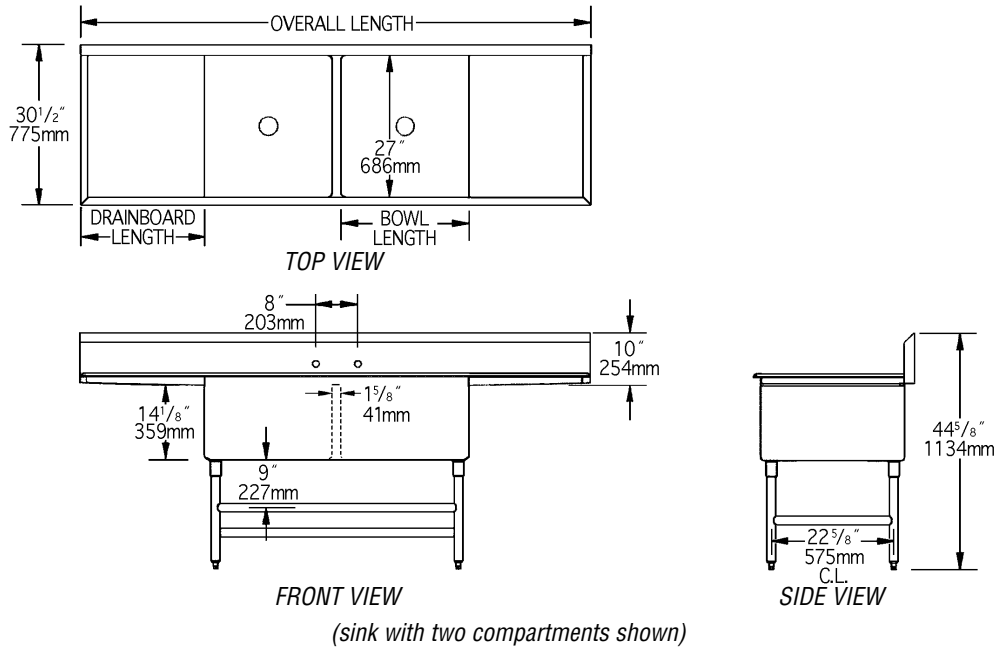

Sinks with Two Compartments

model #	BOWL DIMENSIONS				DRAINBOARDS		OVERALL DIMENSIONS			
	width		length		length		width		length	
	in.	mm	in.	mm	in.	mm	in.	mm	in.	mm
FFN2736-2-24-14/3	27"	686	18"	457	24"	610	30 1/2"	775	85 5/8"	2175
FFN2736-2-30-14/3	27"	686	18"	457	30"	762	30 1/2"	775	97 5/8"	2480
FFN2740-2-24-14/3	27"	686	20"	508	24"	610	30 1/2"	775	89 5/8"	2277
FFN2740-2-30-14/3	27"	686	20"	508	30"	762	30 1/2"	775	101 5/8"	2581
FFN2748-2-24-14/3	27"	686	24"	610	24"	610	30 1/2"	775	97 5/8"	2480
FFN2748-2-30-14/3	27"	686	24"	610	30"	762	30 1/2"	775	109 5/8"	2785
FFN2760-2-24-14/3	27"	686	30"	762	24"	610	30 1/2"	775	109 5/8"	2785
FFN2760-2-30-14/3	27"	686	30"	762	30"	762	30 1/2"	775	121 5/8"	3089

Sinks with Three Compartments*

model #	BOWL DIMENSIONS				DRAINBOARDS		OVERALL DIMENSIONS			
	width		length		length		width		length	
	in.	mm	in.	mm	in.	mm	in.	mm	in.	mm
FFN2754-3-24-14/3	27"	686	18"	457	24"	610	30 1/2"	775	105 1/4"	2673
FFN2754-3-30-14/3	27"	686	18"	457	30"	762	30 1/2"	775	117 1/4"	2978
FFN2760-3-24-14/3	27"	686	20"	508	24"	610	30 1/2"	775	111 1/4"	2826
FFN2760-3-30-14/3	27"	686	20"	508	30"	762	30 1/2"	775	123 1/4"	3131
FFN2772-3-24-14/3	27"	686	24"	610	24"	610	30 1/2"	775	123 1/4"	3131
FFN2772-3-30-14/3	27"	686	24"	610	30"	762	30 1/2"	775	135 1/4"	3435
FFN2790-3-24-14/3	27"	686	30"	762	24"	610	30 1/2"	775	141 1/4"	3588
FFN2790-3-30-14/3	27"	686	30"	762	30"	762	30 1/2"	775	153 1/4"	3893

* Three-Compartment sinks feature two sets of faucet holes.

EAGLE GROUP
 100 Industrial Boulevard, Clayton, DE 19938-8903 USA
 Phone: 302-653-3000 • Fax: 302-653-2065 • www.eaglegrp.com

Foodservice Division: Phone 800-441-8440
 MHC/Retail Display Divisions: Phone 800-637-5100

Printed in U.S.A.
 ©2019 by Eagle Group

Rev. 05/19

Spec sheets available for viewing, printing or downloading from our online literature library at www.eaglegrp.com

Although every attempt has been made to ensure the accuracy of the information provided, we cannot be held responsible for typographical or printing errors. Information and specifications are subject to change without notice. Please confirm at time of order.