



Profit from the Eagle Advantage®

Specification Sheet

Short Form Specifications

Eagle Spec-Master® Plate Cabinet, model _____.
Top is 14 gauge type 304 stainless steel—with ends and rear turned down 90° and rolled rim on front—reinforced with full-length stainless steel hat channel. Full-length fixed center shelf and body are heavy gauge type 430 stainless steel. 1½" O.D. type 304 stainless steel tubular legs with 1" adjustable bullet feet. Available with open front, sliding doors, or hinged doors.



Spec-Master® plate cabinet with open base

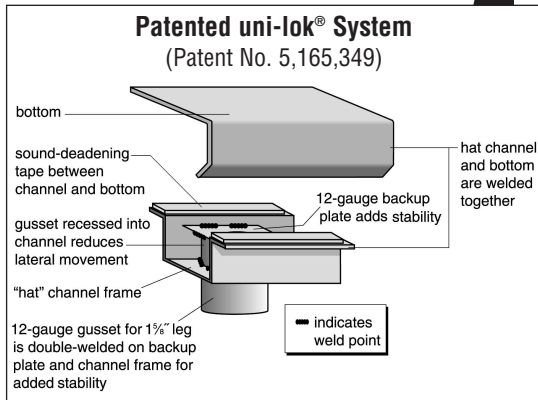

Options / Accessories

- Door locks
- Custom size

EAGLE GROUP
 100 Industrial Boulevard, Clayton, DE 19938-8903 USA
 Phone: 302-653-3000 • Fax: 302-653-2065
 www.eaglegrp.com

Foodservice Division: Phone 800-441-8440
MHC/Retail Display Divisions: Phone 800-637-5100

For custom configuration or fabrication needs, contact our **SpecFAB® Division**.
 Phone: 302-653-3000 • Fax: 302-653-3091 • e-mail: specfab@eaglegrp.com

Spec sheets available for viewing, printing or downloading from our online literature library at www.eaglegrp.com

Eagle Foodservice Equipment, Eagle MHC, SpecFAB®, and Retail Display are divisions of Eagle Group. ©2012 by the Eagle Group

Item No.: _____
 Project No.: _____
 S.I.S. No.: _____

Spec-Master® Plate Cabinets

MODELS:

- | | |
|---------------------------------------|---------------------------------------|
| <input type="checkbox"/> P*1548SE-CS | <input type="checkbox"/> P*1848SE-CS |
| <input type="checkbox"/> P*1560SE-CS | <input type="checkbox"/> P*1860SE-CS |
| <input type="checkbox"/> P*1572SE-CS | <input type="checkbox"/> P*1872SE-CS |
| <input type="checkbox"/> P*1584SE-CS | <input type="checkbox"/> P*1884SE-CS |
| <input type="checkbox"/> P*1596SE-CS | <input type="checkbox"/> P*1896SE-CS |
| <input type="checkbox"/> P*15120SE-CS | <input type="checkbox"/> P*18120SE-CS |
| <input type="checkbox"/> P*15144SE-CS | <input type="checkbox"/> P*18144SE-CS |

* See chart on back for complete model numbers.

Construction

- All-welded design.
- Top mechanically polished to satin finish.
- Sound-deadened between stainless steel hat channel and tabletop, between channel and center shelf, and between channel and bottom.
- 1½" (42mm)-diameter type 304 stainless steel legs.
- 1" (25mm) adjustable metal bullet feet.
- 1½" (38mm) sanitary rolled rim on front, with square edge on rear and ends for flush fit.

Material

- Top is 14 gauge type 304 stainless steel reinforced with a full length stainless steel hat channel support.
- Body and center shelf are heavy gauge type 430 stainless steel.
- Available with open front or with 20 gauge type 430 stainless steel hinged doors** or sliding doors**.
- Optional door locks available. To order, add suffix "-L" to model number. Example: PCH1524SE-CS-L

** Units 48"- to 72"-long feature one pair of doors.
 Units 84"- to 144"-long feature two pairs of doors.

Certifications / Approvals



AUTOQUOTES



EG10.56 Rev. 04/12



Profit from the Eagle Advantage®

Item No.: _____
 Project No.: _____
 S.I.S. No.: _____

Spec-Master® Plate Cabinets

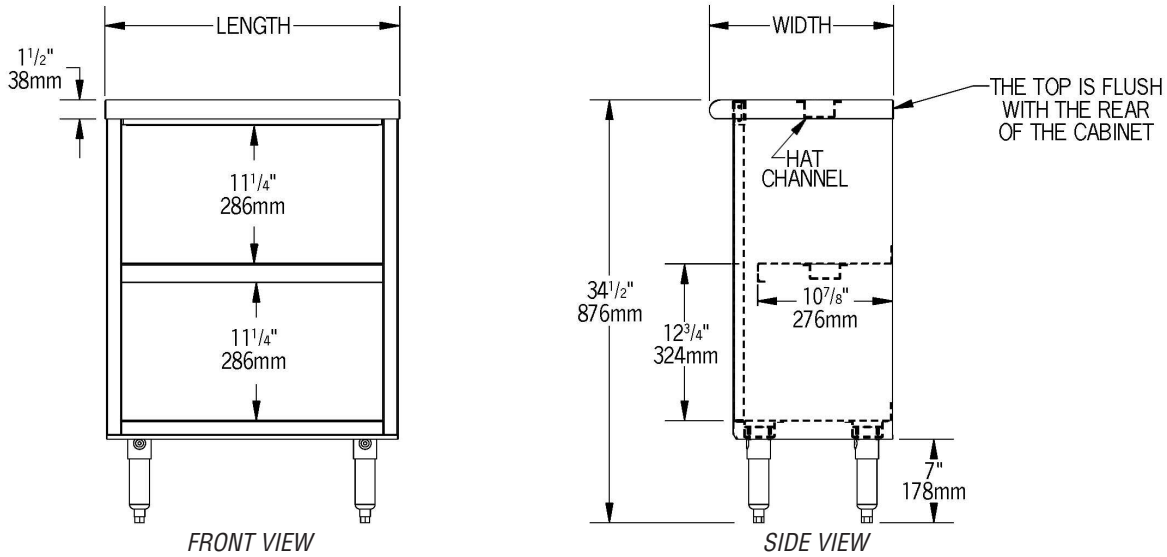

(note: unit with open base shown)

WITH OPEN BASE			WITH SLIDING DOORS			WITH HINGED DOORS			# of legs	width		length	
model #	weight lbs.	weight kg	model #	weight lbs.	weight kg	model #	weight lbs.	weight kg		in.	mm	in.	mm
PC1548SE-CS	135	61.2	PCS1548SE-CS	150	68.0	PCH1548SE-CS	150	68.0	4	15"	381	48"	1219
PC1560SE-CS	175	79.5	PCS1560SE-CS	190	86.2	PCH1560SE-CS	190	86.2	4	15"	381	60"	1524
PC1572SE-CS	215	97.5	PCS1572SE-CS	230	104.3	PCH1572SE-CS	230	104.3	4	15"	381	72"	1829
PC1584SE-CS	265	120.2	PCS1584SE-CS	295	133.8	PCH1584SE-CS	295	133.8	6	15"	381	84"	2134
PC1596SE-CS	305	137.0	PCS1596SE-CS	365	165.6	PCH1596SE-CS	365	165.6	6	15"	381	96"	2438
PC15120SE-CS	345	156.5	PCS15120SE-CS	405	183.7	PCH15120SE-CS	405	183.7	6	15"	381	120"	3048
PC15144SE-CS	425	192.9	PCS15144SE-CS	445	201.9	PCH15144SE-CS	445	201.9	6	15"	381	144"	3658
PC1848SE-CS	140	63.5	PCS1848SE-CS	155	70.3	PCH1848SE-CS	155	70.3	4	18"	457	48"	1219
PC1860SE-CS	180	83.9	PCS1860SE-CS	195	88.5	PCH1860SE-CS	195	88.5	4	18"	457	60"	1524
PC1872SE-CS	220	99.8	PCS1872SE-CS	235	106.6	PCH1872SE-CS	235	106.6	4	18"	457	72"	1829
PC1884SE-CS	270	122.5	PCS1884SE-CS	300	136.1	PCH1884SE-CS	300	136.1	6	18"	457	84"	2134
PC1896SE-CS	310	140.6	PCS1896SE-CS	370	168.6	PCH1896SE-CS	370	168.6	6	18"	457	96"	2438
PC18120SE-CS	350	158.8	PCS18120SE-CS	410	186.0	PCH18120SE-CS	410	186.0	6	18"	457	120"	3048
PC18144SE-CS	430	195.1	PCS18144SE-CS	450	204.1	PCH18144SE-CS	450	204.1	6	18"	457	144"	3658

EAGLE GROUP
 100 Industrial Boulevard, Clayton, DE 19938-8903 USA
 Phone: 302-653-3000 • Fax: 302-653-2065
 www.eaglegrp.com

Foodservice Division: Phone 800-441-8440
 MHC/Retail Display Divisions: Phone 800-637-5100

Printed in U.S.A.
 ©2012 by Eagle Group

Rev. 04/12

Spec sheets available for viewing, printing or downloading from our online literature library at www.eaglegrp.com

Although every attempt has been made to ensure the accuracy of the information provided, we cannot be held responsible for typographical or printing errors. Information and specifications are subject to change without notice. Please confirm at time of order.